

APX™ TWO-WAY RADIOS



# APX 7000 APX 7000XE BASIC SERVICE MANUAL



# Foreword

This manual covers all models of the ASTRO® APX™ 7000/ APX™ 7000XE digital portable radio, unless otherwise specified. It includes all the information necessary to maintain peak product performance and maximum working time, using levels 1 and 2 maintenance procedures. This level of service goes down to the board replacement level and is typical of some local service centers, self-maintained customers, and distributors.

For details on radio operation or component-level troubleshooting, refer to the applicable manuals available separately. A list of related publications is provided in the section, “[Related Publications](#)” on [page 1:v](#) and [page 2:v](#).

## Product Safety and RF Exposure Compliance

<b>ATTENTION!</b>	<b>Before using this radio, read the guide enclosed with your radio which contains important operating instructions for safe usage and RF energy awareness and control for compliance with applicable standards and regulations.</b>
-------------------	--

For a list of Motorola-approved antennas, batteries, and other accessories, visit the following web site: <http://www.motorolasolutions.com>

## Manual Revisions

Changes which occur after this manual is printed are described in FMRs (Florida Manual Revisions). These FMRs provide complete replacement pages for all added, changed, and deleted items, including pertinent parts list data, schematics, and component layout diagrams. To obtain FMRs, contact the Customer Care and Services Division (refer to “[Appendix B Replacement Parts Ordering](#)”).

## Computer Software Copyrights

The Motorola products described in this manual may include copyrighted Motorola computer programs stored in semiconductor memories or other media. Laws in the United States and other countries preserve for Motorola certain exclusive rights for copyrighted computer programs, including, but not limited to, the exclusive right to copy or reproduce in any form the copyrighted computer program. Accordingly, any copyrighted Motorola computer programs contained in the Motorola products described in this manual may not be copied, reproduced, modified, reverse-engineered, or distributed in any manner without the express written permission of Motorola. Furthermore, the purchase of Motorola products shall not be deemed to grant either directly or by implication, estoppel, or otherwise, any license under the copyrights, patents or patent applications of Motorola, except for the normal non-exclusive license to use that arises by operation of law in the sale of a product.

## Document Copyrights

No duplication or distribution of this document or any portion thereof shall take place without the express written permission of Motorola. No part of this manual may be reproduced, distributed, or transmitted in any form or by any means, electronic or mechanical, for any purpose without the express written permission of Motorola.

## Disclaimer

The information in this document is carefully examined, and is believed to be entirely reliable. However, no responsibility is assumed for inaccuracies. Furthermore, Motorola reserves the right to make changes to any products herein to improve readability, function, or design. Motorola does not assume any liability arising out of the applications or use of any product or circuit described herein; nor does it cover any license under its patent rights nor the rights of others.

## Trademarks

MOTOROLA, MOTO, MOTOROLA SOLUTIONS and the Stylized M logo are trademarks or registered trademarks of Motorola Trademark Holdings, LLC and are used under license. All other trademarks are the property of their respective owners. © 2010–2013 Motorola Solutions, Inc. All rights reserved.

---

# **ASTRO<sup>®</sup> APX<sup>™</sup> 7000/ APX 7000XE**

## **Digital Portable Radios**

### **Basic Service Manual**

#### **Contents**

Section 1: APX 7000 Radio

Section 2: APX 7000XE Radio

Section 3: Appendices

## Document History

The following major changes have been implemented in this manual since the previous edition:

Edition	Description	Date
6875962M01-A	Initial edition	Apr. 2009
6875962M01-B	Added APX 7000: UHF1/700-800 and UHF1/VHF bands	Nov. 2009
6875962M01-C	Revert Accessory list back to Rev A.	Nov. 2009
6875962M01-D	Added APX 7000: UHF2/700-800 and UHF2/VHF bands	Jun. 2010
6875962M01-E	APX 7000: Updated Displays and Control Top parts lists. Added Band specific RF Boards reference into Exploded View parts list. APX 7000XE: Initial edition for APX 7000XE (top display model)	Feb. 2011
6875962M01-F	APX 7000: Added UHF1/UHF2 info	Nov. 2011
6875962M01-G	APX 7000XE: Added UHF1/UHF2 info APX 7000XE: Added dual display models APX 7000 and APX 7000XE: Modification on specs and model charts	May. 2012
6875962M01-H	<ul style="list-style-type: none"> <li>• Added Bluetooth Option Board info into Model Charts, Basic Theory of Operations and Disassembly/ Reassembly Chapters</li> <li>• Updated Model Charts (Item number changed from 01009304019 to 01009304024)</li> <li>• Updated Compatibility table for APX 7000 and APX 7000 XE.</li> </ul>	June 2013



# Commercial Warranty

## Limited Warranty

### MOTOROLA COMMUNICATION PRODUCTS

#### I. What This Warranty Covers And For How Long

MOTOROLA SOLUTIONS INC. ("MOTOROLA") warrants the MOTOROLA manufactured Communication Products listed below ("Product") against defects in material and workmanship under normal use and service for a period of time from the date of purchase as scheduled below:

ASTRO APX 7000/ APX 7000XE Digital Portable Units	One (1) Year
Product Accessories	One (1) Year

Motorola, at its option, will at no charge either repair the Product (with new or reconditioned parts), replace it (with a new or reconditioned Product), or refund the purchase price of the Product during the warranty period provided it is returned in accordance with the terms of this warranty. Replaced parts or boards are warranted for the balance of the original applicable warranty period. All replaced parts of Product shall become the property of MOTOROLA.

This express limited warranty is extended by MOTOROLA to the original end user purchaser only and is not assignable or transferable to any other party. This is the complete warranty for the Product manufactured by MOTOROLA. MOTOROLA assumes no obligations or liability for additions or modifications to this warranty unless made in writing and signed by an officer of MOTOROLA. Unless made in a separate agreement between MOTOROLA and the original end user purchaser, MOTOROLA does not warrant the installation, maintenance or service of the Product.

MOTOROLA cannot be responsible in any way for any ancillary equipment not furnished by MOTOROLA which is attached to or used in connection with the Product, or for operation of the Product with any ancillary equipment, and all such equipment is expressly excluded from this warranty. Because each system which may use the Product is unique, MOTOROLA disclaims liability for range, coverage, or operation of the system as a whole under this warranty.

#### II. General Provisions

This warranty sets forth the full extent of MOTOROLA'S responsibilities regarding the Product. Repair, replacement or refund of the purchase price, at MOTOROLA's option, is the exclusive remedy. THIS WARRANTY IS GIVEN IN LIEU OF ALL OTHER EXPRESS WARRANTIES. IMPLIED WARRANTIES, INCLUDING WITHOUT LIMITATION, IMPLIED WARRANTIES OF MERCHANTABILITY AND FITNESS FOR A PARTICULAR PURPOSE, ARE LIMITED TO THE DURATION OF THIS LIMITED WARRANTY. IN NO EVENT SHALL MOTOROLA BE LIABLE FOR DAMAGES IN EXCESS OF THE PURCHASE PRICE OF THE PRODUCT, FOR ANY LOSS OF USE, LOSS OF TIME, INCONVENIENCE, COMMERCIAL LOSS, LOST PROFITS OR SAVINGS OR OTHER INCIDENTAL, SPECIAL OR CONSEQUENTIAL DAMAGES ARISING OUT OF THE USE OR INABILITY TO USE SUCH PRODUCT, TO THE FULL EXTENT SUCH MAY BE DISCLAIMED BY LAW.

### III. State Law Rights

SOME STATES DO NOT ALLOW THE EXCLUSION OR LIMITATION OF INCIDENTAL OR CONSEQUENTIAL DAMAGES OR LIMITATION ON HOW LONG AN IMPLIED WARRANTY LASTS, SO THE ABOVE LIMITATION OR EXCLUSIONS MAY NOT APPLY.

This warranty gives specific legal rights, and there may be other rights which may vary from state to state.

### IV. How To Get Warranty Service

You must provide proof of purchase (bearing the date of purchase and Product item serial number) in order to receive warranty service and, also, deliver or send the Product item, transportation and insurance prepaid, to an authorized warranty service location. Warranty service will be provided by Motorola through one of its authorized warranty service locations. If you first contact the company which sold you the Product, it can facilitate your obtaining warranty service. You can also call Motorola at 1-888-567-7347 US/Canada.

### V. What This Warranty Does Not Cover

- A. Defects or damage resulting from use of the Product in other than its normal and customary manner.
- B. Defects or damage from misuse, accident, water, or neglect.
- C. Defects or damage from improper testing, operation, maintenance, installation, alteration, modification, or adjustment.
- D. Breakage or damage to antennas unless caused directly by defects in material workmanship.
- E. A Product subjected to unauthorized Product modifications, disassemblies or repairs (including, without limitation, the addition to the Product of non-Motorola supplied equipment) which adversely affect performance of the Product or interfere with Motorola's normal warranty inspection and testing of the Product to verify any warranty claim.
- F. Product which has had the serial number removed or made illegible.
- G. Rechargeable batteries if:
  - H. any of the seals on the battery enclosure of cells are broken or show evidence of tampering.
  - I. the damage or defect is caused by charging or using the battery in equipment or service other than the Product for which it is specified.
- J. Freight costs to the repair depot.
- K. A Product which, due to illegal or unauthorized alteration of the software/firmware in the Product, does not function in accordance with MOTOROLA's published specifications or the FCC certification labeling in effect for the Product at the time the Product was initially distributed from MOTOROLA.
- L. Scratches or other cosmetic damage to Product surfaces that does not affect the operation of the Product.
- M. Normal and customary wear and tear.

## VI. Patent And Software Provisions

MOTOROLA will defend, at its own expense, any suit brought against the end user purchaser to the extent that it is based on a claim that the Product or parts infringe a United States patent, and MOTOROLA will pay those costs and damages finally awarded against the end user purchaser in any such suit which are attributable to any such claim, but such defense and payments are conditioned on the following:

- A. that MOTOROLA will be notified promptly in writing by such purchaser of any notice of such claim;
- B. that MOTOROLA will have sole control of the defense of such suit and all negotiations for its settlement or compromise; and
- C. should the Product or parts become, or in MOTOROLA's opinion be likely to become, the subject of a claim of infringement of a United States patent, that such purchaser will permit MOTOROLA, at its option and expense, either to procure for such purchaser the right to continue using the Product or parts or to replace or modify the same so that it becomes noninfringing or to grant such purchaser a credit for the Product or parts as depreciated and accept its return. The depreciation will be an equal amount per year over the lifetime of the Product or parts as established by MOTOROLA.

MOTOROLA will have no liability with respect to any claim of patent infringement which is based upon the combination of the Product or parts furnished hereunder with software, apparatus or devices not furnished by MOTOROLA, nor will MOTOROLA have any liability for the use of ancillary equipment or software not furnished by MOTOROLA which is attached to or used in connection with the Product. The foregoing states the entire liability of MOTOROLA with respect to infringement of patents by the Product or any parts thereof.

Laws in the United States and other countries preserve for MOTOROLA certain exclusive rights for copyrighted MOTOROLA software such as the exclusive rights to reproduce in copies and distribute copies of such Motorola software. MOTOROLA software may be used in only the Product in which the software was originally embodied and such software in such Product may not be replaced, copied, distributed, modified in any way, or used to produce any derivative thereof. No other use including, without limitation, alteration, modification, reproduction, distribution, or reverse engineering of such MOTOROLA software or exercise of rights in such MOTOROLA software is permitted. No license is granted by implication, estoppel or otherwise under MOTOROLA patent rights or copyrights.

## VII. Governing Law

This Warranty is governed by the laws of the State of Illinois, USA.

## Notes

---

**ASTRO APX 7000/ APX 7000XE**  
**Digital Portable Radios**

Section 1  
APX 7000

---

---

## Notes

# Table of Contents

<b>Model Numbering, Charts, and Specifications</b> .....	<b>1:ix</b>
Portable Radio Model Numbering System .....	1:ix
ASTRO APX 7000 700–800 MHz and VHF Model Chart.....	1:x
ASTRO APX 7000 700–800 MHz and UHF1 Model Chart.....	1:xi
ASTRO APX 7000 UHF1 and VHF Model Chart.....	1:xii
ASTRO APX 7000 UHF1 and UHF2 Model Chart.....	1:xiii
ASTRO APX 7000 700–800 MHz and UHF2 Model Chart.....	1:xiv
ASTRO APX 7000 UHF2 and VHF Model Chart.....	1:xv
Specifications for VHF Radios.....	1:xvi
Specifications for 700–800 MHz Radios.....	1:xvii
Specifications for UHF1 Radios.....	1:xviii
Specifications for UHF2 Radios.....	1:xix
<b>Chapter 1 Introduction</b> .....	<b>1:1-1</b>
1.1 Manual Contents.....	1:1-1
1.2 Notations Used in This Manual.....	1:1-1
1.3 Radio Description .....	1:1-2
1.4 FLASHport® .....	1:1-2
<b>Chapter 2 Basic Maintenance</b> .....	<b>1:2-1</b>
2.1 General Maintenance .....	1:2-1
2.2 Handling Precautions.....	1:2-1
<b>Chapter 3 Basic Theory of Operation</b> .....	<b>1:3-1</b>
3.1 Major Assemblies .....	1:3-1
3.2 Analog Mode of Operation.....	1:3-3
3.3 Digital (ASTRO) Mode of Operation .....	1:3-11
3.4 Controller Section .....	1:3-12
<b>Chapter 4 Recommended Test Equipment and Service Aids</b> .....	<b>1:4-1</b>
4.1 Recommended Test Equipment .....	1:4-1
4.2 Service Aids.....	1:4-2
4.3 Field Programming .....	1:4-3
<b>Chapter 5 Performance Checks</b> .....	<b>1:5-1</b>
5.1 Test Equipment Setup .....	1:5-1
5.2 Display Radio Test Mode (Dual-Display Version).....	1:5-3
5.3 Top-Display Version Radio Test Mode .....	1:5-7
5.4 Receiver Performance Checks .....	1:5-9
5.5 Transmitter Performance Checks .....	1:5-10

<b>Chapter 6</b>	<b>Radio Alignment Procedures</b>	<b>1:6-1</b>
6.1	Test Setup	1:6-1
6.2	Tuner Main Menu	1:6-2
6.3	Softpot	1:6-2
6.4	Radio Information	1:6-4
6.5	Transmitter Alignments	1:6-4
6.6	Front End Filter Alignment	1:6-22
6.7	Performance Testing	1:6-24
<b>Chapter 7</b>	<b>Encryption</b>	<b>1:7-1</b>
7.1	Load an Encryption Key	1:7-1
7.2	Multikey Feature	1:7-1
7.3	Select an Encryption Key	1:7-2
7.4	Select an Encryption Index	1:7-3
7.5	Erase an Encryption Key	1:7-3
<b>Chapter 8</b>	<b>Disassembly/Reassembly Procedures</b>	<b>1:8-1</b>
8.1	APX 7000 Exploded View (Main Subassemblies)	1:8-1
8.2	Required Tools and Supplies	1:8-5
8.3	Fastener Torque Chart	1:8-5
8.4	Antenna	1:8-6
8.5	Battery	1:8-7
8.6	Universal Connector Cover	1:8-10
8.7	Radio Disassembly	1:8-12
8.8	Serviceable Components of the Main Sub-Assemblies	1:8-20
8.9	Radio Reassembly	1:8-31
8.10	Ensuring Radio Submergibility	1:8-39
<b>Chapter 9</b>	<b>Basic Troubleshooting</b>	<b>1:9-1</b>
9.1	Power-Up Error Codes	1:9-1
9.2	Operational Error Codes	1:9-2
9.3	Receiver Troubleshooting	1:9-2
9.4	Transmitter Troubleshooting	1:9-3
9.5	Encryption Troubleshooting	1:9-4
9.6	Bluetooth Option / Expansion Board Troubleshooting	1:9-4
9.7	Bluetooth Troubleshooting	1:9-5
<b>Chapter 10</b>	<b>Exploded Views and Parts Lists</b>	<b>1:10-1</b>
10.1	APX 7000 Dual Display Exploded View	1:10-2
10.2	APX 7000 Dual Display Exploded View Parts List	1:10-3
10.3	APX 7000 Top Display Exploded View	1:10-4
10.4	APX 7000 Top Display Exploded View Parts List	1:10-5
<b>Index</b>		<b>1:Index-1</b>



## List of Tables

Table 1-1.	ASTRO APX 7000 Basic Features .....	1:1-2
Table 4-1.	Recommended Test Equipment.....	1:4-1
Table 4-2.	Service Aids .....	1:4-2
Table 5-1.	Initial Equipment Control Settings.....	1:5-2
Table 5-2.	Test-Mode Displays.....	1:5-3
Table 5-3.	Test Frequencies (MHz).....	1:5-5
Table 5-4.	Test Environments .....	1:5-5
Table 5-5.	Receiver Performance Checks .....	1:5-9
Table 5-6.	Receiver Tests for ASTRO Conventional Channels* .....	1:5-9
Table 5-7.	Transmitter Performance Checks .....	1:5-10
Table 5-8.	Transmitter Tests for ASTRO Conventional Channels* .....	1:5-11
Table 6-1.	Reference Oscillator Alignment .....	1:6-6
Table 7-1.	Encryption Key Zeroization Options.....	1:7-4
Table 8-1.	APX 7000 Partial Exploded View Parts List.....	1:8-4
Table 8-2.	Required Tools and Supplies .....	1:8-5
Table 8-3.	Required Tools and Supplies .....	1:8-5
Table 9-1.	Power-Up Error Code Displays.....	1:9-1
Table 9-2.	Operational Error Code Displays .....	1:9-2
Table 9-3.	Receiver Troubleshooting Chart .....	1:9-2
Table 9-4.	Transmitter Troubleshooting Chart .....	1:9-3
Table 9-5.	Encryption Troubleshooting Chart .....	1:9-4
Table 9-6.	Bluetooth Option/Expansion Board Troubleshooting Chart .....	1:9-4
Table 9-7.	Bluetooth Troubleshooting Chart .....	1:9-5
Table 10-1.	APX 7000 Exploded Views .....	1:10-1
Table 10-2.	Compatibility Table.....	1:10-6

## Related Publications

APX 7000 Digital Portable Radios Full Feature User Guide .....	6875945M01
APX 7000 Digital Portable Radios Half Feature User Guide.....	6875952M01
APX 7000 Digital Portable Radios Detailed Service Manual.....	6875961M01
APX 7000 Digital Portable Radios User Guide (CD): VHF/700–800 MHz .....	PMLN5335_
APX 7000 Digital Portable Radios User Guide (CD): UHF1/700–800 MHz .....	PMLN5335_
APX 7000 Digital Portable Radios User Guide (CD): UHF1/VHF .....	PMLN5335_
APX 7000 Digital Portable Radios User Guide (CD): UHF2/700–800 MHz .....	PMLN5335_
APX 7000 Digital Portable Radios User Guide (CD): UHF2/VHF .....	PMLN5335_
APX 7000 Digital Portable Radios User Guide (CD): UHF1/UHF2 .....	PMLN5335_

## List of Figures

Figure 3-1. APX 7000 Overall Block Diagram (VOCON Board MNCN6200/ MNCN6201) .....	1:3-2
Figure 3-2. APX 7000 Overall Block Diagram (VOCON Board MNCN6202/ MNCN6203) .....	1:3-2
Figure 3-3. Receiver Block Diagram (VHF and 700–800 MHz).....	1:3-3
Figure 3-4. Receiver Block Diagram (UHF1 and 700–800 MHz) .....	1:3-3
Figure 3-5. Receiver Block Diagram (UHF1 and VHF).....	1:3-4
Figure 3-6. Receiver Block Diagram (UHF1 and UHF2) .....	1:3-4
Figure 3-7. Receiver Block Diagram (UHF2 and 700–800 MHz) .....	1:3-5
Figure 3-8. Receiver Block Diagram (UHF2 and VHF).....	1:3-5
Figure 3-9. GPS Diagram .....	1:3-6
Figure 3-10. Transceiver (VHF and 700–800 MHz) Block Diagram .....	1:3-8
Figure 3-11. Transceiver (UHF1 and 700–800 MHz) Block Diagram .....	1:3-8
Figure 3-12. Transceiver (VHF and UHF1) Block Diagram .....	1:3-9
Figure 3-13. Transceiver (UHF1 and UHF2) Block Diagram .....	1:3-9
Figure 3-14. Transceiver (UHF2 and 700–800 MHz) Block Diagram .....	1:3-10
Figure 3-15. Transceiver (VHF and UHF2) Block Diagram .....	1:3-10
Figure 3-16. Controller Block Diagram .....	1:3-12
Figure 5-1. Performance Checks Test Setup.....	1:5-1
Figure 6-1. Radio Alignment Test Setup.....	1:6-1
Figure 6-2. Tuner Software Main Menu .....	1:6-2
Figure 6-3. Typical Softpot Screen .....	1:6-3
Figure 6-4. Radio Information Screen .....	1:6-4
Figure 6-5. Reference Oscillator Alignment Screen (VHF and 700–800 MHz, UHF1 and 700–800 MHz, and UHF2 and 700–800 MHz).....	1:6-5
Figure 6-6. Reference Oscillator Alignment Screen (UHF1 and VHF, and UHF1 and UHF2).....	1:6-5
Figure 6-7. Reference Oscillator Alignment Screen (UHF2 and VHF) .....	1:6-6
Figure 6-8. Transmit Power Characterization Points Alignment Screen (VHF and 700–800 MHz).....	1:6-7
Figure 6-9. Transmit Power Characterization Points Alignment Screen (UHF1 and 700–800 MHz) ...	1:6-8
Figure 6-10. Transmit Power Characterization Points Alignment Screen (UHF1 and VHF).....	1:6-8
Figure 6-11. Transmit Power Characterization Points Alignment Screen (UHF1 and UHF2) .....	1:6-9
Figure 6-12. Transmit Power Characterization Points Alignment Screen (UHF2 and 700–800 MHz) ...	1:6-9
Figure 6-13. Transmit Power Characterization Points Alignment Screen (UHF2 and VHF).....	1:6-10
Figure 6-14. Transmit Power Characterization Alignment Screen (VHF and 700–800 MHz) .....	1:6-11
Figure 6-15. Transmit Power Characterization Alignment Screen (UHF1 and 700–800 MHz) .....	1:6-11
Figure 6-16. Transmit Power Characterization Alignment Screen (UHF1 and VHF) .....	1:6-12
Figure 6-17. Transmit Power Characterization Alignment Screen (UHF1 and UHF2) .....	1:6-12
Figure 6-18. Transmit Power Characterization Alignment Screen (UHF2 and 700–800 MHz) .....	1:6-13
Figure 6-19. Transmit Power Characterization Alignment Screen (UHF2 and VHF) .....	1:6-13
Figure 6-20. PA Saturation Referencing Alignment Screen (VHF and 700–800 MHz) .....	1:6-14
Figure 6-21. PA Saturation Referencing Alignment Screen (UHF1 and 700–800 MHz) .....	1:6-15
Figure 6-22. PA Saturation Referencing Alignment Screen (UHF1 and VHF) .....	1:6-15
Figure 6-23. PA Saturation Referencing Alignment Screen (UHF1 and UHF2) .....	1:6-16
Figure 6-24. PA Saturation Referencing Alignment Screen (UHF2 and 700–800 MHz) .....	1:6-16
Figure 6-25. PA Saturation Referencing Alignment Screen (UHF2 and VHF) .....	1:6-17
Figure 6-26. Transmit Deviation Balance Alignment Screen (VHF and 700–800 MHz).....	1:6-18
Figure 6-27. Transmit Deviation Balance Alignment Screen (UHF1 and 700–800 MHz).....	1:6-19
Figure 6-28. Transmit Deviation Balance Alignment Screen (UHF1 and VHF) .....	1:6-19
Figure 6-29. Transmit Deviation Balance Alignment Screen (UHF1 and UHF2).....	1:6-20
Figure 6-30. Transmit Deviation Balance Alignment Screen (UHF2 and 700–800 MHz).....	1:6-20
Figure 6-31. Transmit Deviation Balance Alignment Screen (UHF2 and VHF) .....	1:6-21
Figure 6-32. Front End Filter Alignment Screen (UHF1).....	1:6-22

---

Figure 6-33. Front End Filter Alignment Screen (UHF2).....	1:6-23
Figure 6-34. Bit Error Rate Screen.....	1:6-25
Figure 6-35. Transmitter Test Pattern Screen.....	1:6-26
Figure 8-1. APX 7000 Dual Display Partial Exploded View.....	1:8-2
Figure 8-2. APX 7000 Top Display Partial Exploded View.....	1:8-3
Figure 8-3. Attaching the Antenna.....	1:8-6
Figure 8-4. Removing the Antenna.....	1:8-6
Figure 8-5. Attaching Battery – Battery Seal.....	1:8-7
Figure 8-6. Attaching Battery – Memory Door.....	1:8-8
Figure 8-7. Attaching Battery – Slide into Position.....	1:8-8
Figure 8-8. Squeezing the Release Latches.....	1:8-9
Figure 8-9. Removing the Battery.....	1:8-9
Figure 8-10. Removing the Thumb Screw.....	1:8-10
Figure 8-11. Engaging Hook and Seating Cover.....	1:8-11
Figure 8-12. Securing the Cover.....	1:8-11
Figure 8-13. Remove Center Screws.....	1:8-12
Figure 8-14. Remove Bottom Screws.....	1:8-12
Figure 8-15. Remove Top Screws.....	1:8-13
Figure 8-16. Remove Speaker Module.....	1:8-13
Figure 8-17. Remove Flex Connectors and Expansion Board Assembly.....	1:8-14
Figure 8-18. Unlock Levers.....	1:8-14
Figure 8-19. Remove Bluetooth Option Board.....	1:8-14
Figure 8-20. Remove Antenna Coax Cable Connector.....	1:8-15
Figure 8-21. Remove Housing.....	1:8-15
Figure 8-22. Remove Back Chassis Assembly from Main Chassis Assembly.....	1:8-16
Figure 8-23. Remove RF Board Assembly.....	1:8-17
Figure 8-24. Remove VOCON Board Assembly.....	1:8-18
Figure 8-25. Remove Knobs and Fastener Hardware.....	1:8-19
Figure 8-26. Remove Control Top Bezel Assembly.....	1:8-19
Figure 8-27. Remove Control Top Assembly (9).....	1:8-19
Figure 8-28. Serviceable Components – Main Chassis Assembly.....	1:8-20
Figure 8-29. Remove Chassis Ground Contact.....	1:8-22
Figure 8-30. Control Top Assembly and Control Top Seal.....	1:8-22
Figure 8-31. Top Bezel Assembly.....	1:8-23
Figure 8-32. VOCON Board Assembly.....	1:8-23
Figure 8-33. RF Board Assembly.....	1:8-24
Figure 8-34. Expansion Board Assembly.....	1:8-25
Figure 8-35. Back Chassis Assembly (Dual Display Version).....	1:8-25
Figure 8-36. Back Chassis Assembly (Top Display Version).....	1:8-27
Figure 8-37. Main Housing Assembly (Dual Display Version).....	1:8-27
Figure 8-38. Main Housing Assembly (Top Display Version).....	1:8-28
Figure 8-39. Speaker Module.....	1:8-29
Figure 8-40. Speaker Grille Assembly.....	1:8-30
Figure 8-41. Control Top Bezel Assembly.....	1:8-31
Figure 8-42. Top Bezel Assembly.....	1:8-31
Figure 8-43. Inspect Pads.....	1:8-32
Figure 8-44. Insert VOCON Board.....	1:8-33
Figure 8-45. Connect RF Board to VOCON Board.....	1:8-33
Figure 8-46. Place Back Chassis.....	1:8-34
Figure 8-47. Place Housing into Main Chassis.....	1:8-34
Figure 8-48. Assemble Expansion Board Assembly.....	1:8-35
Figure 8-49. Insert Flex Connectors.....	1:8-35
Figure 8-50. Assemble Bluetooth Option Board.....	1:8-36
Figure 8-51. Lock Levers.....	1:8-36

---

Figure 8-52. Lubricate Main Chassis.....	1:8-36
Figure 8-53. Insert Speaker Module .....	1:8-37
Figure 8-54. Insert Top Screws .....	1:8-37
Figure 8-55. Remove Center Screws .....	1:8-38
Figure 8-56. Insert Center Screws .....	1:8-38
Figure 8-57. Insert Bottom Screws .....	1:8-38
Figure 8-58. Attaching Grille Eliminator.....	1:8-41
Figure 10-1. APX 7000 Dual Display Exploded View .....	1:10-2
Figure 10-2. APX 7000 Top Display Exploded View .....	1:10-4

# Model Numbering, Charts, and Specifications

## Portable Radio Model Numbering System

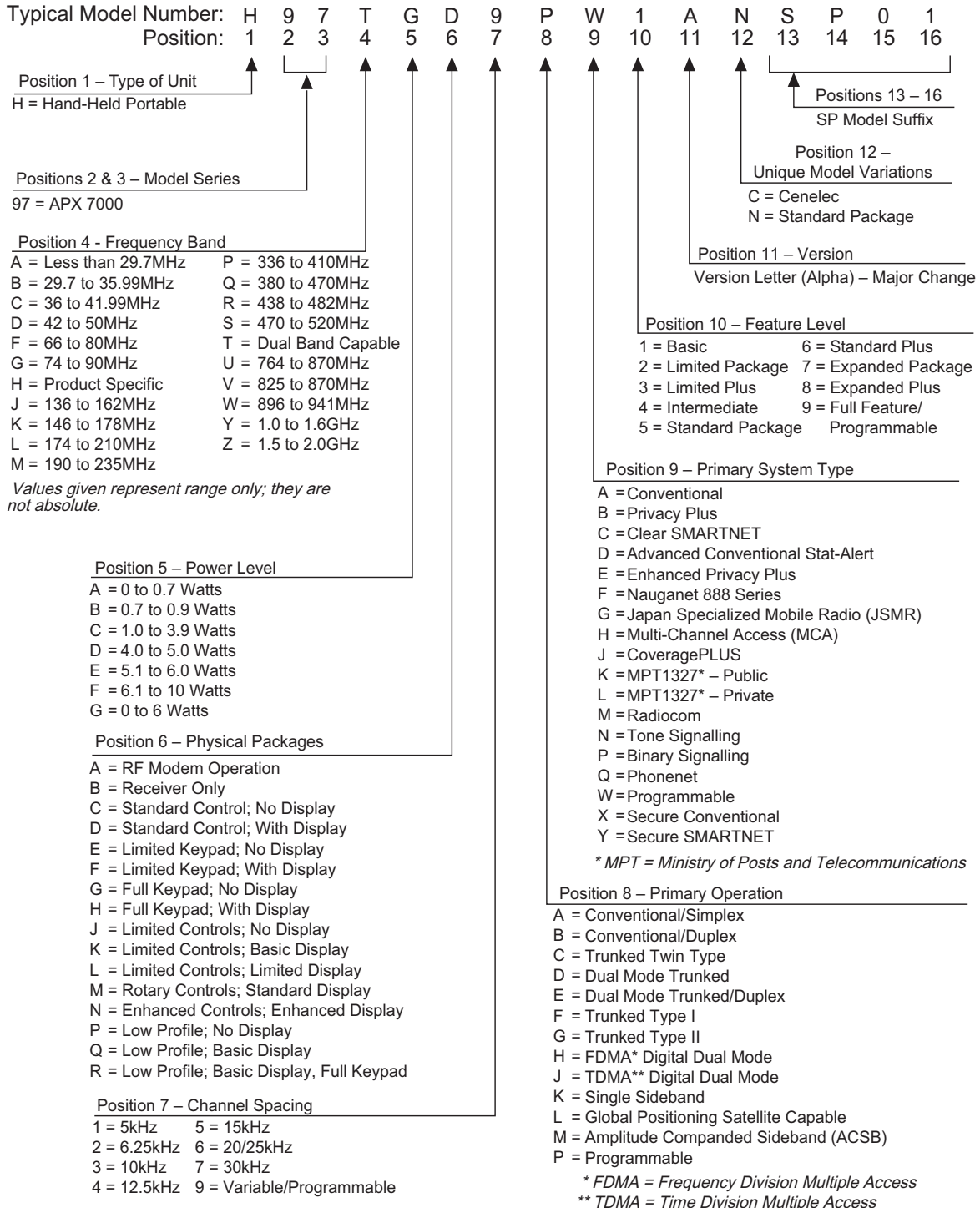

## ASTRO APX 7000 700–800 MHz and VHF Model Chart

MODEL NUMBER:		H97TGD9PW1_N	
FCC ID:		AZ489FT7036	
MODEL DESCRIPTION:		700–800 / VHF, APX 7000	
Top Display Model			
Dual Display Model			
		ITEM NUMBER	DESCRIPTION
X	X	01009304001	Sub-Assembly, Main Chassis
	X	01009304024	Display, Color
●	●	01009304004	Grille, Speaker, Black
●	●	01009304005	Grille, Speaker, Safety Yellow
●	●	01009304006	Grille, Speaker, Impact Green
X	X	0375962B01	Screw, Chassis (M2.5 x 0.45 x 31mm)
X	X	0375962B02	Screw, Chassis (M2.5 x 0.45 x 25mm)
X	X	0375962B03	Screw, Chassis (M2.5 x 0.45 x 7.3mm)
X	X	1110027B23	Grease, Fluorocarbon Lubricant
X	X	1375044C02	Assembly, Control Top
X	X	1375579B03	Bezel, Outer Top
X	X	1575250H01	Cover, Universal Connector
X		1575356H01	Cover, Belt Clip, Top Display
X	X	32009064001	Plug, Controls Flex Support
X	X	3271829H01	Seal, Battery Connector
X	X	3275623B02	Pad, Thermal, Outer
X	X	3275882B01	Seal, Memory Card Portal
X	X	3371896H01	Label, Grille Top APX 7000
X		3385836D09	Label, Blank, Top Display
X	X	3875126H01	Cap, Chassis Screw Boss
X	X	75009299001	Pad, Thermal, Inner
X	X	7575218H01	Pad, Thermal, Expansion / VOCON
X	X	MHLN6977_ / MHLN7035_*	Assembly, Expansion Board
	X	MNCN6200_ / MNCN6202_**	Assembly, VOCON Board, Dual Display
X		MNCN6201_ / MNCN6203_**	Assembly, VOCON Board, Top Display
	X	01009304011	Assembly, Main Housing, Dual Display, Black
	●	01009304007	Assembly, Main Housing, Dual Display, Safety Yellow
	●	01009304008	Assembly, Main Housing, Dual Display, Impact Green
	●	01009304015	Assembly, Main Housing, Top Display, Black
●		01009304009	Assembly, Main Housing, Top Display, Safety Yellow
●		01009304010	Assembly, Main Housing, Top Display, Impact Green
X	X	NHN7002_	Assembly, Speaker Module
	X	NHN7017_	Sub-Assembly, Back Chassis, Dual Display
X		NHN7004_	Sub-Assembly, Back Chassis, Top Display
X	X	MNUR4001_	Assembly, RF Board
o	o	NNTN8160_	Bluetooth Upgrade Kit
Δ	Δ	NUUK6000_	Assembly Bluetooth Option Board
X	X	PMLN5335_	User Guide CD, APX 7000/ APX 7000XE

**Note:**

- X = Item Included.
- = Option available.
- o = Optional.
- Δ = Comes with unit equipped with Bluetooth Option Board
- \* Refer [Appendix A](#) for antennas, batteries and other applicable accessories.
- \* With TI Chipset.
- \*\* With PCN Display Vocon.

## ASTRO APX 7000 700–800 MHz and UHF1 Model Chart

MODEL NUMBER:		H97TGD9PW1_N	
FCC ID:		AZ489FT7040	
MODEL DESCRIPTION:		700–800 / UHF1, APX 7000	
Top Display Model			
Dual Display Model			
		ITEM NUMBER	DESCRIPTION
X	X	01009304001	Sub-Assembly, Main Chassis
	X	01009304024	Display, Color
●	●	01009304004	Grille, Speaker, Black
●	●	01009304005	Grille, Speaker, Safety Yellow
●	●	01009304006	Grille, Speaker, Impact Green
X	X	0375962B01	Screw, Chassis (M2.5 x 0.45 x 31mm)
X	X	0375962B02	Screw, Chassis (M2.5 x 0.45 x 25mm)
X	X	0375962B03	Screw, Chassis (M2.5 x 0.45 x 7.3mm)
X	X	1110027B23	Grease, Fluorocarbon Lubricant
X	X	1375044C02	Assembly, Control Top
X	X	1375579B03	Bezel, Outer Top
X	X	1575250H01	Cover, Universal Connector
X	X	1575356H01	Cover, Belt Clip, Top Display
X	X	32009064001	Plug, Controls Flex Support
X	X	3271829H01	Seal, Battery Connector
X	X	3275623B02	Pad, Thermal, Outer
X	X	3275882B01	Seal, Memory Card Portal
X	X	3371896H01	Label, Grille Top APX 7000
X		3385836D09	Label, Blank, Top Display
X	X	3875126H01	Cap, Chassis Screw Boss
X	X	75009299001	Pad, Thermal, Inner
X	X	7575218H01	Pad, Thermal, Expansion / VOCON
X	X	MHLN6977_ / MHLN7035_*	Assembly, Expansion Board
X	X	MNCN6200_ / MNCN6202_**	Assembly, VOCON Board, Dual Display
X	X	MNCN6201_ / MNCN6203_**	Assembly, VOCON Board, Top Display
	●	01009304011	Assembly, Main Housing, Dual Display, Black
	●	01009304007	Assembly, Main Housing, Dual Display, Safety Yellow
	●	01009304008	Assembly, Main Housing, Dual Display, Impact Green
●		01009304015	Assembly, Main Housing, Top Display, Black
●		01009304009	Assembly, Main Housing, Top Display, Safety Yellow
●		01009304010	Assembly, Main Housing, Top Display, Impact Green
X	X	NHN7002_	Assembly, Speaker Module
	X	NHN7017_	Sub-Assembly, Back Chassis, Dual Display
X		NHN7004_	Sub-Assembly, Back Chassis, Top Display
X	X	MNUS4000_	Assembly, RF Board
o	o	NNTN8160_	Bluetooth Upgrade Kit
Δ	Δ	NUUK6000_	Assembly Bluetooth Option Board
X	X	PMLN5335_	User Guide CD, APX 7000/ APX 7000XE

**Note:**

- X = Item Included.
- = Option available.
- o = Optional.
- Δ = Comes with unit equipped with Bluetooth Option Board
- Refer [Appendix A](#) for antennas, batteries and other applicable accessories.
- \* With TI Chipset.
- \*\* With PCN Display Vocon.

## ASTRO APX 7000 UHF1 and VHF Model Chart

MODEL NUMBER:		H97TGD9PW1_N	
FCC ID:		AZ489FT4886	
MODEL DESCRIPTION:		UHF1 / VHF, APX 7000	
Top Display Model			
Dual Display Model			
		ITEM NUMBER	DESCRIPTION
X	X	01009304001	Sub-Assembly, Main Chassis
	X	01009304024	Display, Color
●	●	01009304004	Grille, Speaker, Black
●	●	01009304005	Grille, Speaker, Safety Yellow
●	●	01009304006	Grille, Speaker, Impact Green
X	X	0375962B01	Screw, Chassis (M2.5 x 0.45 x 31mm)
X	X	0375962B02	Screw, Chassis (M2.5 x 0.45 x 25mm)
X	X	0375962B03	Screw, Chassis (M2.5 x 0.45 x 7.3mm)
X	X	1110027B23	Grease, Fluorocarbon Lubricant
X	X	1375044C02	Assembly, Control Top
X	X	1375579B03	Bezel, Outer Top
X	X	1575250H01	Cover, Universal Connector
X		1575356H01	Cover, Belt Clip, Top Display
X	X	32009064001	Plug, Controls Flex Support
X	X	3271829H01	Seal, Battery Connector
X	X	3275623B02	Pad, Thermal, Outer
X	X	3275882B01	Seal, Memory Card Portal
X	X	3371896H01	Label, Grille Top APX 7000
X		3385836D09	Label, Blank, Top Display
X	X	3875126H01	Cap, Chassis Screw Boss
X	X	75009299001	Pad, Thermal, Inner
X	X	7575218H01	Pad, Thermal, Expansion / VOCON
X	X	MHLN6977_ / MHLN7035_*	Assembly, Expansion Board
	X	MNCN6200_ / MNCN6202_**	Assembly, VOCON Board, Dual Display
X		MNCN6201_ / MNCN6203_**	Assembly, VOCON Board, Top Display
	●	01009304011	Assembly, Main Housing, Dual Display, Black
	●	01009304007	Assembly, Main Housing, Dual Display, Safety Yellow
	●	01009304008	Assembly, Main Housing, Dual Display, Impact Green
●		01009304015	Assembly, Main Housing, Top Display, Black
●		01009304009	Assembly, Main Housing, Top Display, Safety Yellow
●		01009304010	Assembly, Main Housing, Top Display, Impact Green
X	X	NHN7002_	Assembly, Speaker Module
	X	NHN7017_	Sub-Assembly, Back Chassis, Dual Display
X		NHN7004_	Sub-Assembly, Back Chassis, Top Display
X	X	MNUT4000_	Assembly, RF Board
o	o	NNTN8160_	Bluetooth Upgrade Kit
Δ	Δ	NUUK6000_	Assembly Bluetooth Option Board
X	X	PMLN5335_	User Guide CD, APX 7000/ APX 7000XE

**Note:**

- X = Item Included.
- = Option available.
- o = Optional.
- Δ = Comes with unit equipped with Bluetooth Option Board
- \* Refer [Appendix A](#) for antennas, batteries and other applicable accessories.
- \* With TI Chipset.
- \*\* With PCN Display Vocon.



## ASTRO APX 7000 UHF1 and UHF2 Model Chart

MODEL NUMBER:		H97TGD9PW1_N	
FCC ID:		AZ489FT4906	
MODEL DESCRIPTION:		UHF1 / UHF2, APX 7000	
Top Display Model			
Dual Display Model			
		ITEM NUMBER	DESCRIPTION
X	X	01009304001	Sub-Assembly, Main Chassis
	X	01009304024	Display, Color
●	●	01009304004	Grille, Speaker, Black
●	●	01009304005	Grille, Speaker, Safety Yellow
●	●	01009304006	Grille, Speaker, Impact Green
X	X	0375962B01	Screw, Chassis (M2.5 x 0.45 x 31mm)
X	X	0375962B02	Screw, Chassis (M2.5 x 0.45 x 25mm)
X	X	0375962B03	Screw, Chassis (M2.5 x 0.45 x 7.3mm)
X	X	1110027B23	Grease, Fluorocarbon Lubricant
X	X	1375044C02	Assembly, Control Top
X	X	1375579B03	Bezel, Outer Top
X	X	1575250H01	Cover, Universal Connector
X		1575356H01	Cover, Belt Clip, Top Display
X	X	32009064001	Plug, Controls Flex Support
X	X	3271829H01	Seal, Battery Connector
X	X	3275623B02	Pad, Thermal, Outer
X	X	3275882B01	Seal, Memory Card Portal
X	X	3371896H01	Label, Grille Top APX 7000
X		3385836D09	Label, Blank, Top Display
X	X	3875126H01	Cap, Chassis Screw Boss
X	X	75009299001	Pad, Thermal, Inner
X	X	7575218H01	Pad, Thermal, Expansion / VOCON
X	X	MHLN6977_ / MHLN7035_*	Assembly, Expansion Board
	X	MNCN6200_ / MNCN6202_**	Assembly, VOCON Board, Dual Display
X		MNCN6201_ / MNCN6203_**	Assembly, VOCON Board, Top Display
	●	01009304011	Assembly, Main Housing, Dual Display, Black
	●	01009304007	Assembly, Main Housing, Dual Display, Safety Yellow
	●	01009304008	Assembly, Main Housing, Dual Display, Impact Green
●		01009304015	Assembly, Main Housing, Top Display, Black
●		01009304009	Assembly, Main Housing, Top Display, Safety Yellow
●		01009304010	Assembly, Main Housing, Top Display, Impact Green
X	X	NHN7002_	Assembly, Speaker Module
	X	NHN7017_	Sub-Assembly, Back Chassis, Dual Display
X		NHN7004_	Sub-Assembly, Back Chassis, Top Display
X	X	MNUE7367_	Assembly, RF Board
○	○	NNTN8160_	Bluetooth Upgrade Kit
△	△	NUUK6000_	Assembly Bluetooth Option Board
X	X	PMLN5335_	User Guide CD, APX 7000/ APX 7000XE

**Note:**

- X = Item Included.
- = Option available.
- = Optional.
- △ = Comes with unit equipped with Bluetooth Option Board
- \* Refer [Appendix A](#) for antennas, batteries and other applicable accessories.
- \* With TI Chipset.
- \*\* With PCN Display Vocon.

## ASTRO APX 7000 700–800 MHz and UHF2 Model Chart

MODEL NUMBER:		H97TGD9PW1_N	
FCC ID:		AZ489FT7042	
MODEL DESCRIPTION:		700–800 / UHF2, APX 7000	
Top Display Model			
Dual Display Model			
		ITEM NUMBER	DESCRIPTION
X	X	01009304001	Sub-Assembly, Main Chassis
	X	01009304024	Display, Color
●	●	01009304004	Grille, Speaker, Black
●	●	01009304005	Grille, Speaker, Safety Yellow
●	●	01009304006	Grille, Speaker, Impact Green
X	X	0375962B01	Screw, Chassis (M2.5 x 0.45 x 31mm)
X	X	0375962B02	Screw, Chassis (M2.5 x 0.45 x 25mm)
X	X	0375962B03	Screw, Chassis (M2.5 x 0.45 x 7.3mm)
X	X	1110027B23	Grease, Fluorocarbon Lubricant
X	X	1375044C02	Assembly, Control Top
X	X	1375579B03	Bezel, Outer Top
X	X	1575250H01	Cover, Universal Connector
X		1575356H01	Cover, Belt Clip, Top Display
X	X	32009064001	Plug, Controls Flex Support
X	X	3271829H01	Seal, Battery Connector
X	X	3275623B02	Pad, Thermal, Outer
X	X	3275882B01	Seal, Memory Card Portal
X	X	3371896H01	Label, Grille Top APX 7000
X		3385836D09	Label, Blank, Top Display
X	X	3875126H01	Cap, Chassis Screw Boss
X	X	75009299001	Pad, Thermal, Inner
X	X	7575218H01	Pad, Thermal, Expansion / VOCON
X	X	MHLN6977_ / MHLN7035_*	Assembly, Expansion Board
	X	MNCN6200_ / MNCN6202_**	Assembly, VOCON Board, Dual Display
X		MNCN6201_ / MNCN6203_**	Assembly, VOCON Board, Top Display
	●	01009304011	Assembly, Main Housing, Dual Display, Black
	●	01009304007	Assembly, Main Housing, Dual Display, Safety Yellow
	●	01009304008	Assembly, Main Housing, Dual Display, Impact Green
●		01009304015	Assembly, Main Housing, Top Display, Black
●		01009304009	Assembly, Main Housing, Top Display, Safety Yellow
●		01009304010	Assembly, Main Housing, Top Display, Impact Green
X	X	NHN7002_	Assembly, Speaker Module
	X	NHN7017_	Sub-Assembly, Back Chassis, Dual Display
X		NHN7004_	Sub-Assembly, Back Chassis, Top Display
X	X	MNUS4002_	Assembly, RF Board
o	o	NNTN8160_	Bluetooth Upgrade Kit
Δ	Δ	NUUK6000_	Assembly Bluetooth Option Board
X	X	PMLN5335_	User Guide CD, APX 7000/ APX 7000XE

**Note:**

- X = Item Included.
- = Option available.
- o = Optional.
- Δ = Comes with unit equipped with Bluetooth Option Board
- \* Refer [Appendix A](#) for antennas, batteries and other applicable accessories.
- \* With TI Chipset.
- \*\* With PCN Display Vocon.

## ASTRO APX 7000 UHF2 and VHF Model Chart

MODEL NUMBER:		H97TGD9PW1_N	
FCC ID:		AZ489FT4893	
MODEL DESCRIPTION:		UHF2 / VHF, APX 7000	
Top Display Model			
Dual Display Model			
		ITEM NUMBER	DESCRIPTION
X	X	01009304001	Sub-Assembly, Main Chassis
	X	01009304024	Display, Color
●	●	01009304004	Grille, Speaker, Black
●	●	01009304005	Grille, Speaker, Safety Yellow
●	●	01009304006	Grille, Speaker, Impact Green
X	X	0375962B01	Screw, Chassis (M2.5 x 0.45 x 31mm)
X	X	0375962B02	Screw, Chassis (M2.5 x 0.45 x 25mm)
X	X	0375962B03	Screw, Chassis (M2.5 x 0.45 x 7.3mm)
X	X	1110027B23	Grease, Fluorocarbon Lubricant
X	X	1375044C02	Assembly, Control Top
X	X	1375579B03	Bezel, Outer Top
X	X	1575250H01	Cover, Universal Connector
X		1575356H01	Cover, Belt Clip, Top Display
X	X	32009064001	Plug, Controls Flex Support
X	X	3271829H01	Seal, Battery Connector
X	X	3275623B02	Pad, Thermal, Outer
X	X	3275882B01	Seal, Memory Card Portal
X	X	3371896H01	Label, Grille Top APX 7000
X		3385836D09	Label, Blank, Top Display
X	X	3875126H01	Cap, Chassis Screw Boss
X	X	75009299001	Pad, Thermal, Inner
X	X	7575218H01	Pad, Thermal, Expansion / VOCON
X	X	MHLN6977_ / MHLN7035_*	Assembly, Expansion Board
	X	MNCN6200_ / MNCN6202_**	Assembly, VOCON Board, Dual Display
X		MNCN6201_ / MNCN6203_**	Assembly, VOCON Board, Top Display
	●	01009304011	Assembly, Main Housing, Dual Display, Black
	●	01009304007	Assembly, Main Housing, Dual Display, Safety Yellow
	●	01009304008	Assembly, Main Housing, Dual Display, Impact Green
●		01009304015	Assembly, Main Housing, Top Display, Black
●		01009304009	Assembly, Main Housing, Top Display, Safety Yellow
●		01009304010	Assembly, Main Housing, Top Display, Impact Green
X	X	NHN7002_	Assembly, Speaker Module
	X	NHN7017_	Sub-Assembly, Back Chassis, Dual Display
X		NHN7004_	Sub-Assembly, Back Chassis, Top Display
X	X	MNUT4004_	Assembly, RF Board
o	o	NNTN8160_	Bluetooth Upgrade Kit
Δ	Δ	NUUK6000_	Assembly Bluetooth Option Board
X	X	PMLN5335_	User Guide CD, APX 7000/ APX 7000XE

**Note:**

- X = Item Included.
- = Option available.
- o = Optional.
- Δ = Comes with unit equipped with Bluetooth Option Board
- \* Refer [Appendix A](#) for antennas, batteries and other applicable accessories.
- \* With TI Chipset.
- \*\* With PCN Display Vocon.

# Specifications for VHF Radios

All specifications are per Telecommunications Industries Association TIA-603 unless otherwise noted.

GENERAL	RECEIVER	TRANSMITTER
<b>Temperature Range:</b> <b>Operating:</b> -30°C to +60°C <b>Storage:</b> -40°C to +85°C  <b>Power Supply:</b> Nickel-Metal-Hydride Battery (NiMH) or Lithium-Ion Battery (Li-Ion)  <b>Battery Voltage:</b> <b>Nominal:</b> 7.5 Vdc <b>Range:</b> 6 to 9 Vdc  <b>Transmit Current Drain (Typical):</b> 2398 mA <b>Receive Current Drain (Rated Audio):</b> 273 mA <b>Standby Current Drain:</b> 142 mA  <b>Recommended IMPRES Battery:</b> Li-Ion (2900mAh, IP67): NNTN7038_1 or Li-Ion (2150mAh, Slim, IP67): PMNN4403_ or Li-Ion (4200mAh, Rugged): NNTN7034_ or Li-Ion (4100mAh, Rugged) <sup>2</sup> : NNTN7033_ or NiMH (2100mAh, IP67): NNTN7037_ or NiMH (2100mAh, Rugged): NNTN7573_ or NiMH (2000mAh, IP67) <sup>2</sup> : NNTN7036_ or Li-Ion (2300mAh, Rugged) <sup>2</sup> : NNTN8092_ or NiMH (2000mAh, Rugged) <sup>2</sup> : NNTN7035_  <b>Dimensions<sup>3</sup>:</b> <b>Without Battery (Radio Only):</b> H = 6.29" (159.7 mm) W <sup>4</sup> = 2.98" (75.6 mm) / 2.31" (58.6 mm) D <sup>5</sup> = 1.25" (31.7 mm) / 1.40" (35.6 mm) <b>With Li-Ion Battery<sup>6</sup>:</b> H = 6.55" (166.3 mm) W <sup>4</sup> = 2.98" (75.6 mm) / 2.31" (58.6 mm) D <sup>5</sup> = 1.65" (41.8 mm) / 1.40" (35.6 mm) <b>With NiMH Battery<sup>7</sup>:</b> H = 8.55" (217.1 mm) W <sup>4</sup> = 2.98" (75.6 mm) / 2.31" (58.6 mm) D <sup>5</sup> = 1.65" (41.8 mm) / 1.40" (35.6 mm)  <b>Weight: (w/o Antenna):</b> <b>Less Battery:</b> 12.2 oz (346 g) <b>With Li-Ion<sup>6</sup>:</b> 18.7 oz (530 g) <b>With Li-Ion Ultra High Cap<sup>8</sup>:</b> 22.9 oz (648 g) <b>With NiMH<sup>7</sup>:</b> 24.0 oz (681 g)	<b>Frequency Range:</b> 136–174 MHz  <b>Bandwidth:</b> 38 MHz  <b>Analog Sensitivity (typical) (12 dB SINAD):</b> 0.216 µV  <b>Digital Sensitivity (typical) (1% BER):</b> 0.277 µV <b>(5% BER):</b> 0.188 µV  <b>Intermodulation Rejection (typical):</b> 80.5 dB  <b>Selectivity<sup>9</sup> (typical):</b> <b>(25 kHz Channel):</b> 79.3 dB <b>(12.5 kHz Channel):</b> 70 dB  <b>Spurious Rejection (typical):</b> 93.2 dB  <b>Frequency Stability (-30+60°C; 25°C reference):</b> ±0.0001%  <b>Rated Audio:</b> <b>Internal Speaker:</b> 1 W <b>External Speaker:</b> 500 mW  <b>FM Hum and Noise (typical):</b> 25 kHz -53.8 dB 12.5 kHz -48 dB  <b>Distortion (typical):</b> 1.2%  <b>Channel Spacing:</b> 12.5/20/25 kHz	<b>Frequency Range:</b> 136–174 MHz  <b>RF Power:</b> <b>136–174 MHz:</b> 1–6 Watts  <b>Frequency Stability (-30 to +60°C; 25°C ref.):</b> ±0.0001%  <b>Emission (typical conducted):</b> -75 dBc  <b>FM Hum and Noise (typical):</b> 25 kHz -47 dB 12.5 kHz -45 dB  <b>Distortion (typical):</b> 0.50%  <b>Modulation Limiting:</b> 25 kHz chnls ±5.0 kHz 20 kHz chnls ±4.0 kHz 12.5 kHz chnls ±2.5 kHz  <b>ACPR (typical):</b> 25 kHz -78 dBc 12.5 kHz -68 dBc  <b>Emissions Designators:</b> 11K0F3E, 16K0F3E, 8K10F1D, 8K10F1E, 8K10F1W, 20K0F1E  <b>Note:</b> 1. Default APX 7000 Battery 2. Intrinsically Safe. 3. H = Height; W = Width; D = Depth. 4. W = (Width @ Top) / (Width @ PTT). 5. D = (Depth @ Bottom) / (Depth @ PTT). 6. Measured with NNTN7038_. 7. Measured with NNTN7035_. 8. Measured with NNTN7033_. 9. Single tone test.

Specifications subject to change without notice.

## Specifications for 700–800 MHz Radios

All specifications are per Telecommunications Industries Association TIA-603 unless otherwise noted.

GENERAL	RECEIVER	TRANSMITTER
<b>Temperature Range:</b> <b>Operating:</b> -30°C to +60°C <b>Storage:</b> -40°C to +85°C  <b>Power Supply:</b> Nickel-Metal-Hydrate Battery (NiMH) or Lithium-Ion Battery (Li-Ion)  <b>Battery Voltage:</b> <b>Nominal:</b> 7.5 Vdc <b>Range:</b> 6 to 9 Vdc  <b>Transmit Current Drain (Typical):</b> 1499 mA <b>Receive Current Drain (Rated Audio):</b> 278 mA <b>Standby Current Drain:</b> 148 mA  <b>Recommended IMPRES Battery:</b> <b>Li-Ion (2900mAh, IP67):</b> NNTN7038_1 <b>or Li-Ion (2150mAh, Slim, IP67):</b> PMNN4403_ <b>or Li-Ion (4200mAh, Rugged):</b> NNTN7034_ <b>or Li-Ion (4100mAh, Rugged)<sup>2</sup>:</b> NNTN7033_ <b>or NiMH (2100mAh, IP67):</b> NNTN7037_ <b>or NiMH (2100mAh, Rugged):</b> NNTN7573_ <b>or NiMH (2000mAh, IP67)<sup>2</sup>:</b> NNTN7036_ <b>or Li-Ion (2300mAh, Rugged)<sup>2</sup>:</b> NNTN8092_ <b>or NiMH (2000mAh, Rugged)<sup>2</sup>:</b> NNTN7035_  <b>Dimensions<sup>3</sup>:</b> <b>Without Battery (Radio Only):</b> H = 6.29" (159.7 mm) W <sup>4</sup> = 2.98" (75.6 mm) / 2.31" (58.6 mm) D <sup>5</sup> = 1.25" (31.7 mm) / 1.40" (35.6 mm) <b>With Li-Ion Battery<sup>6</sup>:</b> H = 6.55" (166.3 mm) W <sup>4</sup> = 2.98" (75.6 mm) / 2.31" (58.6 mm) D <sup>5</sup> = 1.65" (41.8 mm) / 1.40" (35.6 mm) <b>With NiMH Battery<sup>7</sup>:</b> H = 8.55" (217.1 mm) W <sup>4</sup> = 2.98" (75.6 mm) / 2.31" (58.6 mm) D <sup>5</sup> = 1.65" (41.8 mm) / 1.40" (35.6 mm)  <b>Weight: (w/o Antenna):</b> <b>Less Battery:</b> 12.2 oz (346 g) <b>With Li-Ion<sup>6</sup>:</b> 18.7 oz (530 g) <b>With Li-Ion Ultra High Cap<sup>8</sup>:</b> 22.9 oz (648 g) <b>With NiMH<sup>7</sup>:</b> 24.0 oz (681 g)	<b>Frequency Range:</b> <b>700 MHz:</b> 763–776 MHz <b>800 MHz:</b> 851–870 MHz  <b>Bandwidth:</b> <b>700 MHz:</b> 13 MHz <b>800 MHz:</b> 19 MHz  <b>Analog Sensitivity (typical)</b> <b>(12 dB SINAD):</b> 0.25 µV  <b>Digital Sensitivity (typical)</b> <b>(1% BER: 700/ 800 MHz):</b> 0.347/ 0.333 µV <b>(5% BER):</b> 0.251 µV  <b>Intermodulation Rejection (typical):</b> 80 dB  <b>Selectivity<sup>9</sup> (typical):</b> <b>(25 kHz Channel):</b> 75.7 dB <b>(12.5 kHz Channel):</b> 67.5 dB  <b>Spurious Rejection (typical):</b> 76.6 dB  <b>Frequency Stability</b> <b>(-30+60°C; 25°C reference):</b> ±0.0001%  <b>Rated Audio:</b> <b>Internal Speaker:</b> 1 W <b>External Speaker:</b> 500 mW  <b>FM Hum and Noise (typical):</b> 25 kHz -54 dB 12.5 kHz -48 dB  <b>Distortion (typical):</b> 0.9%  <b>Channel Spacing:</b> 12.5/20/25 kHz	<b>Frequency Range:</b> <b>700 MHz:</b> 763–776; 793–806 MHz <b>800 MHz:</b> 806–825; 851–870 MHz  <b>RF Power:</b> <b>700 MHz:</b> 1–2.7 Watts <b>800 MHz:</b> 1–3 Watts  <b>Frequency Stability</b> <b>(-30 to +60°C; 25°C ref.):</b> <b>700 MHz:</b> ±0.0001% <b>800 MHz:</b> ±0.0001%  <b>Emission</b> <b>(typical conducted):</b> -75 dBc  <b>FM Hum and Noise (typical)</b> 25 kHz chnls (700/ 800 MHz): -48 / -47 dB 12.5 kHz chnls (700/ 800 MHz): -46 / -45 dB  <b>Distortion (typical):</b> <b>700 MHz:</b> 0.60% <b>800 MHz:</b> 1%  <b>Modulation Limiting:</b> 25 kHz chnls ±5.0 kHz 20 kHz chnls ±4.0 kHz 12.5 kHz chnls ±2.5 kHz  <b>ACPR (typical):</b> 25 kHz -78 dBc 12.5 kHz -68 dBc  <b>Emissions Designators:</b> 11K0F3E, 16K0F3E, 8K10F1D, 8K10F1E, 8K10F1W, 20K0F1E  <b>Note:</b> 1. Default APX 7000 Battery 2. Intrinsically Safe. 3. H = Height; W = Width; D = Depth. 4. W = (Width @ Top) / (Width @ PTT). 5. D = (Depth @ Bottom) / (Depth @ PTT). 6. Measured with NNTN7038_. 7. Measured with NNTN7035_. 8. Measured with NNTN7033_. 9. Single tone test.

Specifications subject to change without notice.

## Specifications for UHF1 Radios

All specifications are per Telecommunications Industries Association TIA-603 unless otherwise noted.

**NOTE:** Per the FCC Narrowbanding rules, new products (APX7000 UHF1 / UHF2) submitted for FCC certification after January 1, 2011 are restricted from being granted certification at 25 kHz for United States – State and Local Markets only.

GENERAL	RECEIVER	TRANSMITTER
<b>Temperature Range:</b> <b>Operating:</b> -30°C to +60°C <b>Storage:</b> -40°C to +85°C  <b>Power Supply:</b> Nickel-Metal-Hydrate Battery (NiMH) or Lithium-Ion Battery (Li-Ion)  <b>Battery Voltage:</b> <b>Nominal:</b> 7.5 Vdc <b>Range:</b> 6 to 9 Vdc  <b>Transmit Current Drain (Typical):</b> 2060 mA <b>Receive Current Drain (Rated Audio):</b> 273 mA <b>Standby Current Drain:</b> 142 mA  <b>Recommended IMPRES Battery:</b> Li-Ion (2900mAh, IP67): NNTN7038_1 or Li-Ion (2150mAh, Slim, IP67): PMNN4403_ or Li-Ion (4200mAh, Rugged): NNTN7034_ or Li-Ion (4100mAh, Rugged) <sup>2</sup> : NNTN7033_ or NiMH (2100mAh, IP67): NNTN7037_ or NiMH (2100mAh, Rugged): NNTN7573_ or NiMH (2000mAh, IP67) <sup>2</sup> : NNTN7036_ or Li-Ion (2300mAh, Rugged) <sup>2</sup> : NNTN8092_ or NiMH (2000mAh, Rugged) <sup>2</sup> : NNTN7035_  <b>Dimensions<sup>3</sup>:</b> <b>Without Battery (Radio Only):</b> H = 6.29" (159.7 mm) W <sup>4</sup> = 2.98" (75.6 mm) / 2.31" (58.6 mm) D <sup>5</sup> = 1.25" (31.7 mm) / 1.40" (35.6 mm) <b>With Li-Ion Battery<sup>6</sup>:</b> H = 6.55" (166.3 mm) W <sup>4</sup> = 2.98" (75.6 mm) / 2.31" (58.6 mm) D <sup>5</sup> = 1.65" (41.8 mm) / 1.40" (35.6 mm) <b>With NiMH Battery<sup>7</sup>:</b> H = 8.55" (217.1 mm) W <sup>4</sup> = 2.98" (75.6 mm) / 2.31" (58.6 mm) D <sup>5</sup> = 1.65" (41.8 mm) / 1.40" (35.6 mm)  <b>Weight: (w/o Antenna):</b> <b>Less Battery:</b> 12.2 oz (346 g) <b>With Li-Ion<sup>6</sup>:</b> 18.7 oz (530 g) <b>With Li-Ion Ultra High Cap<sup>8</sup>:</b> 22.9 oz (648 g) <b>With NiMH<sup>7</sup>:</b> 24.0 oz (681 g)	<b>Frequency Range:</b> 380–470 MHz  <b>Bandwidth:</b> 90 MHz  <b>Analog Sensitivity (typical) (12 dB SINAD):</b> 0.234 µV  <b>Digital Sensitivity (typical) (1% BER):</b> 0.307 µV <b>(5% BER):</b> 0.207 µV  <b>Intermodulation Rejection (typical):</b> 80.2 dB  <b>Selectivity<sup>9</sup> (typical):</b> <b>(25 kHz Channel):</b> 78.3 dB <b>(12.5 kHz Channel):</b> 68.1 dB  <b>Spurious Rejection (typical):</b> 80.3 dB  <b>Frequency Stability (-30+60°C; 25°C reference):</b> ±0.0001%  <b>Rated Audio:</b> <b>Internal Speaker:</b> 1 W <b>External Speaker:</b> 500 mW  <b>FM Hum and Noise (typical):</b> 25 kHz -53.5 dB 12.5 kHz -47.4 dB  <b>Distortion (typical):</b> 0.91 %  <b>Channel Spacing:</b> 12.5/20/25 kHz	<b>Frequency Range:</b> 380–470 MHz  <b>RF Power:</b> <b>380–470 MHz:</b> 1–5 Watts  <b>Frequency Stability (-30 to +60°C; 25°C ref.):</b> ±0.0001%  <b>Emission (typical conducted):</b> -75 dBc  <b>FM Hum and Noise (typical):</b> 25 kHz -47 dB 12.5 kHz -45 dB  <b>Distortion (typical):</b> 0.50%  <b>Modulation Limiting:</b> 25 kHz chnls ±5.0 kHz 20 kHz chnls ±4.0 kHz 12.5 kHz chnls ±2.5 kHz  <b>ACPR (typical):</b> 25 kHz -75 dBc 12.5 kHz -68 dBc  <b>Emissions Designators:</b> 11K0F3E, 16K0F3E, 8K10F1D, 8K10F1E, 8K10F1W, 20K0F1E  <b>Note:</b> 1. Default APX 7000 Battery 2. Intrinsically Safe. 3. H = Height; W = Width; D = Depth. 4. W = (Width @ Top) / (Width @ PTT). 5. D = (Depth @ Bottom) / (Depth @ PTT). 6. Measured with NNTN7038_ 7. Measured with NNTN7035_ 8. Measured with NNTN7033_ 9. Single tone test.

Specifications subject to change without notice.

## Specifications for UHF2 Radios

All specifications are per Telecommunications Industries Association TIA-603 unless otherwise noted.

**NOTE:** Per the FCC Narrowbanding rules, new products (APX7000 UHF1 / UHF2) submitted for FCC certification after January 1, 2011 are restricted from being granted certification at 25 kHz for United States – State and Local Markets only

GENERAL	RECEIVER	TRANSMITTER
<b>Temperature Range:</b> <b>Operating:</b> -30°C to +60°C <b>Storage:</b> -40°C to +85°C  <b>Power Supply:</b> Nickel-Metal-Hydride Battery (NiMH) or Lithium-Ion Battery (Li-Ion)  <b>Battery Voltage:</b> <b>Nominal:</b> 7.5 Vdc <b>Range:</b> 6 to 9 Vdc  <b>Transmit Current Drain (Typical):</b> 2100 mA <b>Receive Current Drain (Rated Audio):</b> 268 mA <b>Standby Current Drain:</b> 137 mA  <b>Recommended IMPRES Battery:</b> Li-Ion (2900mAh, IP67): NNTN7038_1 or Li-Ion (2150mAh, Slim, IP67): PMNN4403_ or Li-Ion (4200mAh, Rugged): NNTN7034_ or Li-Ion (4100mAh, Rugged) <sup>2</sup> : NNTN7033_ or NiMH (2100mAh, IP67): NNTN7037_ or NiMH (2100mAh, Rugged): NNTN7573_ or NiMH (2000mAh, IP67) <sup>2</sup> : NNTN7036_ or Li-Ion (2300mAh, Rugged) <sup>2</sup> : NNTN8092_ or NiMH (2000mAh, Rugged) <sup>2</sup> : NNTN7035_  <b>Dimensions<sup>3</sup>:</b> <b>Without Battery (Radio Only):</b> H = 6.29" (159.7 mm) W <sup>4</sup> = 2.98" (75.6 mm) / 2.31" (58.6 mm) D <sup>5</sup> = 1.25" (31.7 mm) / 1.40" (35.6 mm) <b>With Li-Ion Battery<sup>6</sup>:</b> H = 6.55" (166.3 mm) W <sup>4</sup> = 2.98" (75.6 mm) / 2.31" (58.6 mm) D <sup>5</sup> = 1.65" (41.8 mm) / 1.40" (35.6 mm) <b>With NiMH Battery<sup>7</sup>:</b> H = 8.55" (217.1 mm) W <sup>4</sup> = 2.98" (75.6 mm) / 2.31" (58.6 mm) D <sup>5</sup> = 1.65" (41.8 mm) / 1.40" (35.6 mm)  <b>Weight: (w/o Antenna):</b> <b>Less Battery:</b> 12.2 oz (346 g) <b>With Li-Ion<sup>6</sup>:</b> 18.7 oz (530 g) <b>With Li-Ion Ultra High Cap<sup>8</sup>:</b> 22.9 oz (648 g) <b>With NiMH<sup>7</sup>:</b> 24.0 oz (681 g)	<b>Frequency Range:</b> 450–520 MHz  <b>Bandwidth:</b> 70 MHz  <b>Analog Sensitivity (typical) (12 dB SINAD):</b> 0.234 µV  <b>Digital Sensitivity (typical) (1% BER):</b> 0.307 µV <b>(5% BER):</b> 0.207 µV  <b>Intermodulation Rejection (typical):</b> 80.2 dB  <b>Selectivity<sup>9</sup> (typical):</b> <b>(25 kHz Channel):</b> 78.3 dB <b>(12.5 kHz Channel):</b> 67.5 dB  <b>Spurious Rejection (typical):</b> 80.3 dB  <b>Frequency Stability (-30+60°C; 25°C reference):</b> ±0.0001%  <b>Rated Audio:</b> <b>Internal Speaker:</b> 1 W <b>External Speaker:</b> 500 mW  <b>FM Hum and Noise (typical):</b> 25 kHz -53.5 dB 12.5 kHz -47.4 dB  <b>Distortion (typical):</b> 0.91 %  <b>Channel Spacing:</b> 12.5/20/25 kHz	<b>Frequency Range:</b> 450–520 MHz  <b>RF Power:</b> <b>450–520 MHz:</b> 1–5 Watts  <b>Frequency Stability (-30 to +60°C; 25°C ref.):</b> ±0.0001%  <b>Emission (typical conducted):</b> -75 dBc  <b>FM Hum and Noise (typical):</b> 25 kHz -47 dB 12.5 kHz -45 dB  <b>Distortion (typical):</b> 0.50%  <b>Modulation Limiting:</b> 25 kHz chnls ±5.0 kHz 20 kHz chnls ±4.0 kHz 12.5 kHz chnls ±2.5 kHz  <b>ACPR (typical):</b> 25 kHz -75 dBc 12.5 kHz -68 dBc  <b>Emissions Designators:</b> 11K0F3E, 16K0F3E, 8K10F1D, 8K10F1E, 8K10F1W, 20K0F1E  <b>Note:</b> 1. Default APX 7000 Battery 2. Intrinsically Safe. 3. H = Height; W = Width; D = Depth. 4. W = (Width @ Top) / (Width @ PTT). 5. D = (Depth @ Bottom) / (Depth @ PTT). 6. Measured with NNTN7038_. 7. Measured with NNTN7035_. 8. Measured with NNTN7033_. 9. Single tone test.

Specifications subject to change without notice.

## Notes



---

# Chapter 1 Introduction

This manual contains information needed for Levels One and Two radio servicing. Level One servicing consists of radio programming, radio alignment, knobs replacement, and installation and removal of the antenna, belt clip, battery, and universal connector cover. Level Two servicing covers disassembly and reassembly of the radio to replace circuit boards.

## 1.1 Manual Contents

Included in this manual are radio specifications for the VHF(136–174 MHz), UHF1 (380–470 MHz), UHF2 (450–520 MHz) and 764–870 MHz frequency bands, a general description of ASTRO APX 7000 models, recommended test equipment, service aids, radio alignment procedures, general maintenance recommendations, procedures for assembly and disassembly, and exploded views and parts lists.

## 1.2 Notations Used in This Manual

Throughout the text in this publication, you will notice the use of note, caution, warning, and danger notations. These notations are used to emphasize that safety hazards exist, and due care must be taken and observed.

**NOTE:** An operational procedure, practice, or condition that is essential to emphasize.



Caution

CAUTION indicates a potentially hazardous situation which, if not avoided, might result in equipment damage.



WARNING

WARNING indicates a potentially hazardous situation which, if not avoided, could result in death or injury.



DANGER

DANGER indicates an imminently hazardous situation which, if not avoided, will result in death or injury.

### 1.3 Radio Description

The ASTRO APX 7000 radios are among the most sophisticated two-way radios available. These dual band radios are capable of operating in both VHF (136–174 MHz) and 764–870 MHz frequency bands, UHF1 (380–470 MHz) and 764–870 MHz frequency bands, VHF (136–174 MHz) and UHF1 (380–470 MHz) frequency bands, UHF1 (380–450 MHz) and UHF2 (450–520 MHz) frequency bands, UHF2 (450–520 MHz) and 764–870 MHz frequency bands, and, VHF (136–174 MHz) and UHF2 (450–520 MHz) frequency bands.

The ASTRO APX 7000 radio provides improved voice quality across more coverage area. The digital process, called *embedded signaling*, intermixes system signaling information with digital voice, resulting in improved system reliability and the capability of supporting a multitude of advanced features.

ASTRO APX 7000 radios are available in two configurations – Top Display and Dual Display. [Table 1-1](#) describes their basic features.

Table 1-1. ASTRO APX 7000 Basic Features

Feature	Top-Display	Dual-Display
Display	LCD (monochrome) Fully bit-mapped <u>Top Display:</u> <ul style="list-style-type: none"> <li>• 1 line of text (8 characters per line)</li> <li>• 1 line of icons</li> </ul>	LCD <ul style="list-style-type: none"> <li>• Top Display – monochrome</li> <li>• Front Display – color</li> </ul> Fully bit-mapped <u>Top Display:</u> <ul style="list-style-type: none"> <li>• 1 line of text (8 characters per line)</li> <li>• 1 line of icons</li> </ul> <u>Front Display:</u> <i>Dispatch Mode:</i> <ul style="list-style-type: none"> <li>• 5 lines of text (14 characters per line)</li> </ul> <i>List Feature Mode:</i> <ul style="list-style-type: none"> <li>• 8 lines of text (14 characters per line)</li> <li>• 2 lines of icons</li> </ul>
Keypad	None	3 x 2 Menu Buttons (with 4-way Navigation button), 3 x 4 Alphanumeric Keypad
Channel Capability	96 (Basic Zone Bank) 1200 (Enhanced Zone Bank)	2000
Dialing from Prestored List	No	Yes
Programmable Softkeys	No	Yes

### 1.4 FLASHport®

The ASTRO APX 7000 radio utilizes Motorola’s FLASHport technology. FLASHport makes it possible to add software that drives the radio’s capabilities both at the time of purchase and later on. Previously, changing a radio’s features and capabilities meant significant modifications or buying a new radio. But now, similar to how a computer can be loaded with different software, the radio’s features and capabilities can be upgraded with FLASHport software.

---

## Chapter 2 Basic Maintenance

This chapter describes preventive maintenance and handling precautions. Each of these topics provides information vital to the successful operation and maintenance of your radio.

### 2.1 General Maintenance

In order to avoid operating outside the limits set by the FCC, we recommend that you align the ASTRO APX 7000 radio's reference oscillator every time the radio is taken apart, or once per year, whichever comes first. Checking this parameter when the product is placed in service is especially important if the product has been in storage for a significant period of time (6 months or more) between being shipped from the factory and commissioned for service. (See Section [“6.5.1 Reference Oscillator Alignment”](#) on page 1:6-4). Periodic visual inspection and cleaning is also recommended.

**For APX 7000 R (Ruggedized) Radios** – Radio submergibility should be checked annually by qualified service technicians.

#### 2.1.1 Inspection

Check that the external surfaces of the radio are clean and that all external controls and switches are functional. A detailed inspection of the interior electronic circuitry is not needed.

#### 2.1.2 Cleaning

The following procedures describe the recommended cleaning agents and the methods to be used when cleaning the external surfaces of the radio. External surfaces include the housing assembly and battery case. These surfaces should be cleaned whenever a periodic visual inspection reveals the presence of smudges, grease, and/or grime.

The only recommended agent for cleaning the external radio surfaces is a 0.5% solution of a mild dishwashing detergent in water.



Caution

Use all chemicals as prescribed by the manufacturer. Be sure to follow all safety precautions as defined on the label or material safety data sheet.

The effects of certain chemicals and their vapors can have harmful results on certain plastics. Aerosol sprays, tuner cleaners, and other chemicals should be avoided.

The detergent-water solution should be applied sparingly with a stiff, non-metallic, short-bristled brush to work all loose dirt away from the radio. A soft, absorbent, lintless cloth or tissue should be used to remove the solution and dry the radio. Make sure that no water remains entrapped near the connectors, cracks, or crevices.

## 2.2 Handling Precautions

Complementary metal-oxide semiconductor (CMOS) devices, and other high-technology devices, are used in this family of radios. While the attributes of these devices are many, their characteristics make them susceptible to damage by electrostatic discharge (ESD) or high-voltage charges. Damage can be latent, resulting in failures occurring weeks or months later. Therefore, special precautions must be taken to prevent device damage during disassembly, troubleshooting, and repair. Handling precautions are mandatory for this radio, and are especially important in low-humidity conditions.



Caution

- The APX 7000 radio has a vent port that allows for pressure equalization in the radio. Never poke this vent with any objects, such as needles, tweezers, or screwdrivers. This could create a leak path into the radio and, *in the case of APX 7000 R radios*, the radio's submergibility will be lost.
- The pressure equalization vent is located under the main speaker grille near the top left side. Never obstruct or cover the small opening on the top left with any object, including a label. Ensure that no oily substances come in contact with this vent.
- **(APX 7000 R Radios Only)** The APX 7000 R radio is designed to be submerged to a maximum depth of six (6) feet, with a maximum submersion time of 2 hours per U.S. MIL-STD. Exceeding either maximum limit may result in damage to the radio. For specific U.S. MIL-STD details, see Section [“8.10 Ensuring Radio Submergibility”](#) on [page 1:8-39](#).

### 2.2.1 APX 7000 R Radios Only

If the radio battery contact area has been submerged in water, dry and clean the radio battery contacts before attaching a battery to the radio. Otherwise, the water could short-circuit the radio.

If the radio has been submerged in water, shake the radio briskly so that any water that is trapped inside the speaker grille and microphone port can be removed. Otherwise, the water will decrease the audio quality of the radio.

---

## Chapter 3 Basic Theory of Operation

This chapter discusses the basic operational theory of the ASTRO APX 7000 radio, which is a wideband, synthesized radio available in the VHF (136–174 MHz), UHF1 (380–470 MHz), UHF2 (450–520 MHz), 764 to 870 MHz, VHF/764 to 870 MHz, UHF1/764 to 870 MHz, VHF/UHF1, UHF1/UHF2, UHF2/764 to 870 MHz and VHF/UHF2, frequency bands. All ASTRO APX 7000 radios are capable of both analog operation (12.5 kHz or 25 kHz bandwidths), ASTRO mode (digital) operation (12.5 kHz only) and X2-TDMA mode (25 kHz only).

### 3.1 Major Assemblies

The ASTRO APX 7000 radio includes the following major assemblies (see [Figure 3-1](#)):

- **VOCON Board** – contains a dual-core processor which includes both the microcontroller unit (MCU) and a digital signal processor (DSP) core, the processor's memory devices, an audio and power supply support integrated circuit (IC), a digital support IC, external audio power amplifier, and Type III secure IC.
- **Transceiver (XCVR) Board** – contains all transmit, receive, and frequency generation circuitry, including the digital receiver back-end IC and the reference oscillator.
- **Expander Board** – contains the internal audio power amplifier circuitry and the Global Positioning System (GPS) IC and support circuitry.
- **Bluetooth Board** – contains a microprocessor and memory, Bluetooth circuitry, MPP (Motorola Proximity Pairing) circuitry, and an accelerometer.
- **Top Display** – 112 pixels x 32 pixels, transfective monochrome liquid crystal display (LCD).
- **Control Top** – contains five switches: On/Off & Volume Knob, a 16 position Channel/Frequency Knob with concentric 2 position switch (for Secure Enable/Disable operation), a 3 position toggle switch for Zone Selection, and a push button switch used for Emergency calling. The control top also includes an TX/RX LED that is solid amber upon receive, red on PTT, and blinks amber on secure TX/RX.
- **Front Display (Dual-Display Version only)** – 320 pixels x 240 pixels, transfective color LCD.
- **Keypad (Dual-Display Version Only)** – Dual-Display version has a 3 x 2 Menu keypad with 4-way navigation button, and a 3 x 4 alphanumeric keypad.

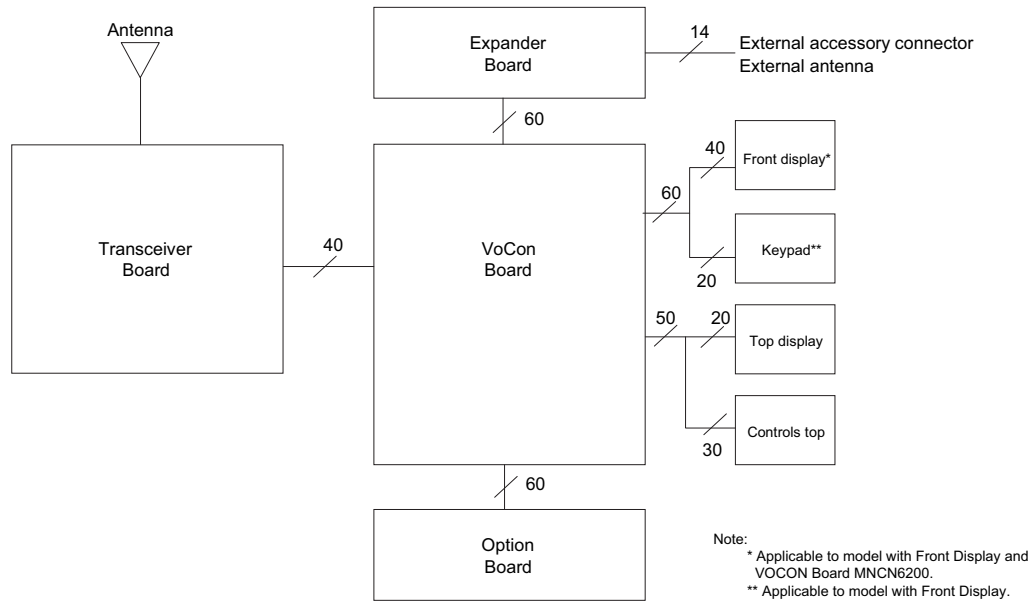

Figure 3-1. APX 7000 Overall Block Diagram (VOCON Board MNCN6200/ MNCN6201)

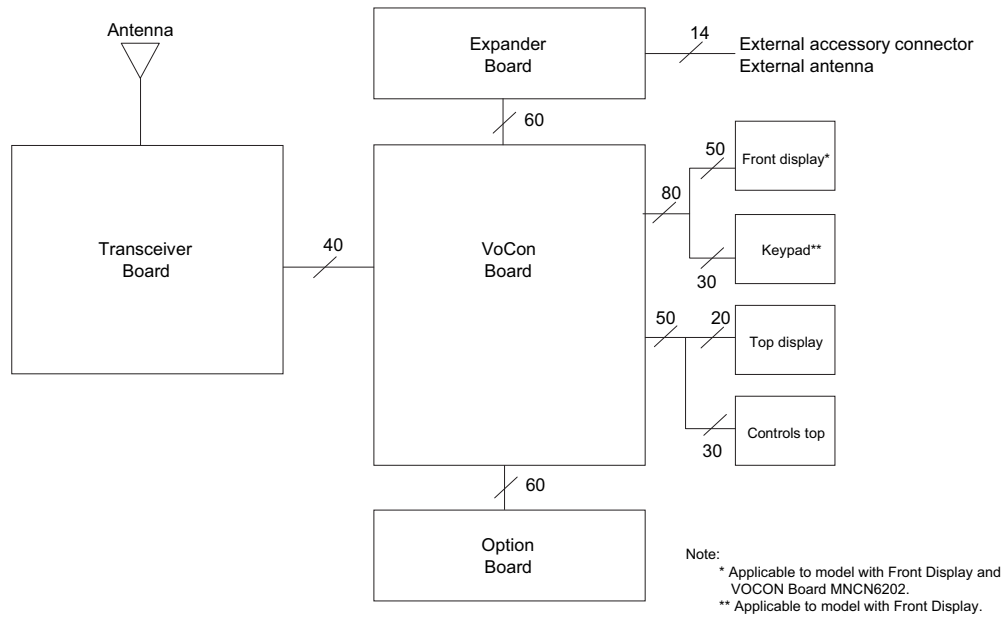

Figure 3-2. APX 7000 Overall Block Diagram (VOCON Board MNCN6202/ MNCN6203)

### 3.2 Analog Mode of Operation

This section provides an overview of the analog mode receive and transmit theory of operation.

#### 3.2.1 Receiving

The RF signal is *received* at the antenna and is routed through the Auxiliary and Multi Switch (SP3T) ICs. The latter contains a switchable attenuator that is enabled at predetermined RF power thresholds present at the antenna port. The output of the Multi-switch IC is applied to the first SPST band select switch to select either VHF or 700–800 bands (see Figure 3-3), UHF1 or 700–800 bands (see Figure 3-4), VHF or UHF1 bands (see Figure 3-5), UHF1 or UHF2 bands (see Figure 3-6), UHF2 or 700–800 bands (see Figure 3-7) and VHF or UHF2 bands (see Figure 3-8).

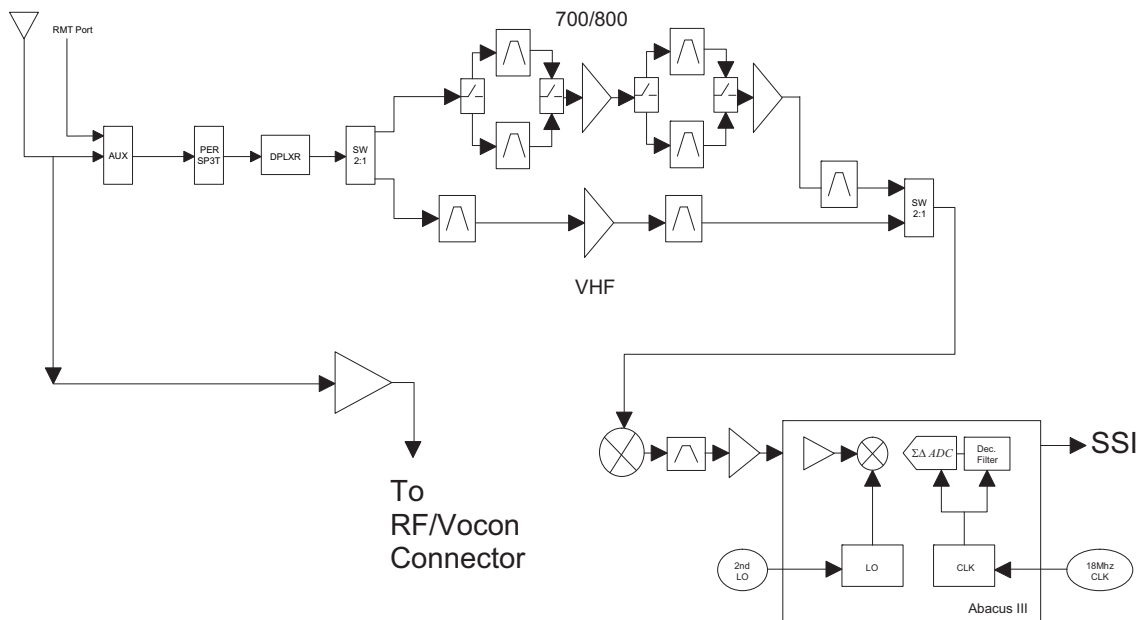

Figure 3-3. Receiver Block Diagram (VHF and 700–800 MHz)

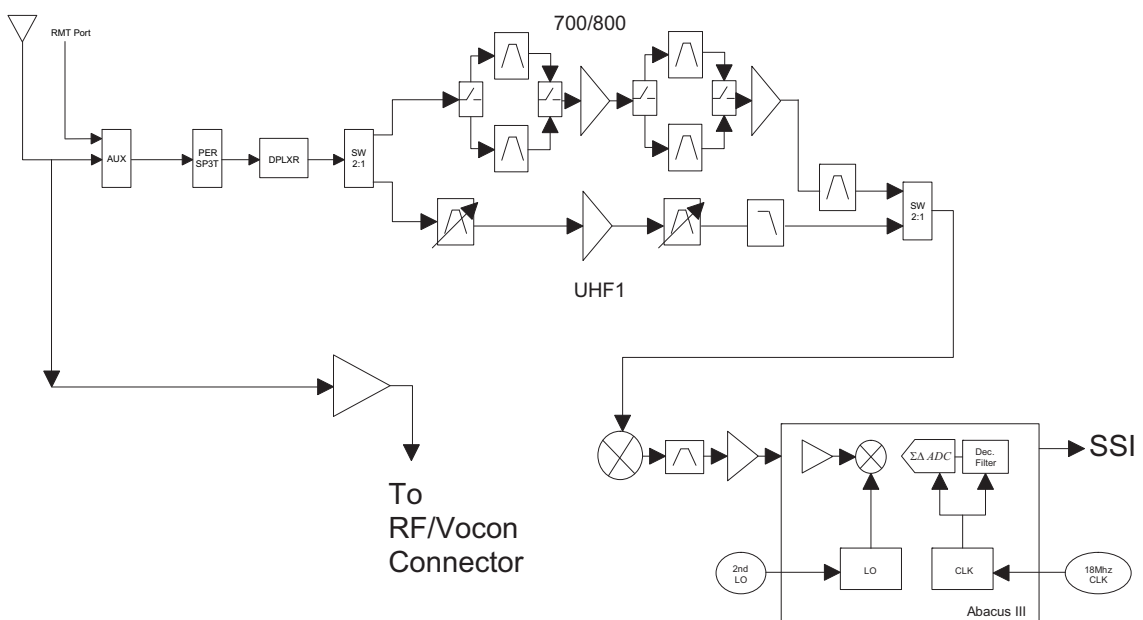

Figure 3-4. Receiver Block Diagram (UHF1 and 700–800 MHz)

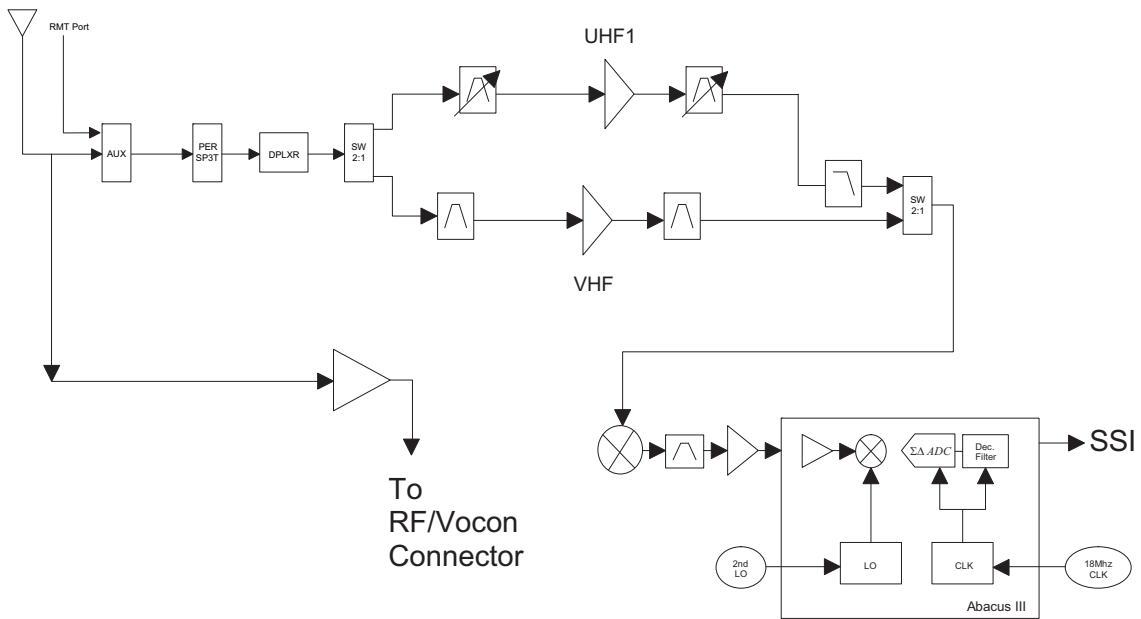

Figure 3-5. Receiver Block Diagram (UHF1 and VHF)

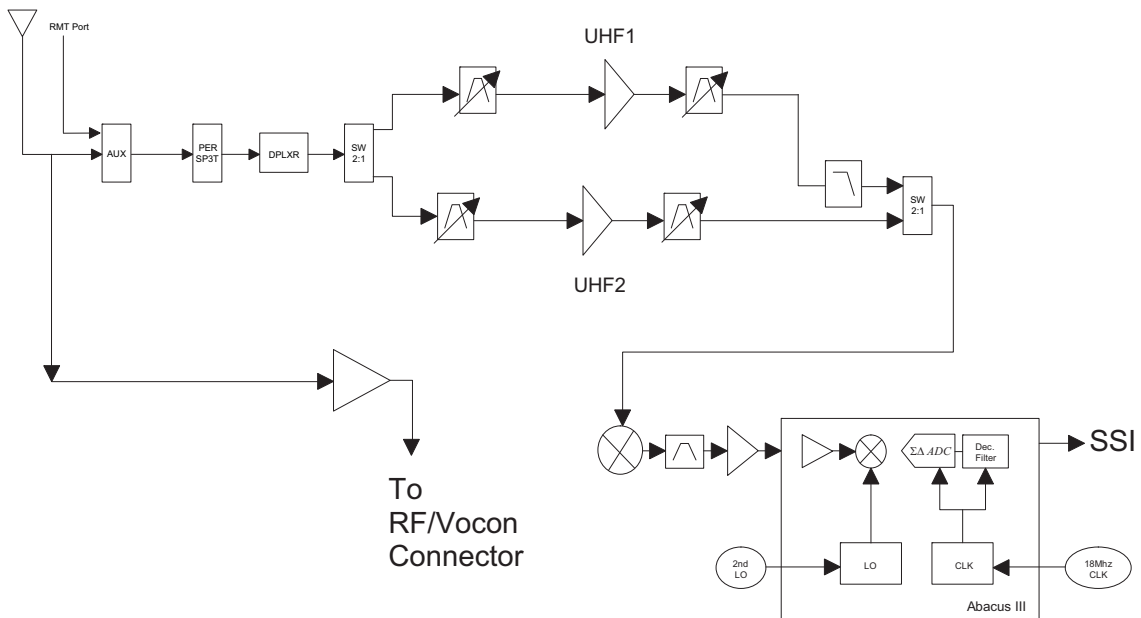

Figure 3-6. Receiver Block Diagram (UHF1 and UHF2)



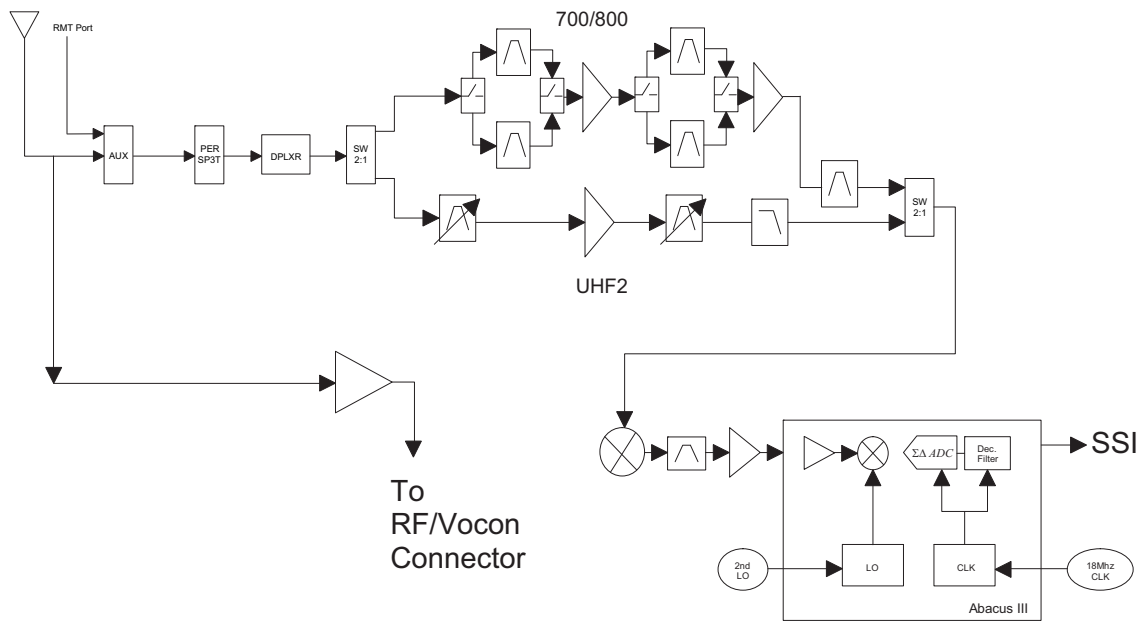

Figure 3-7. Receiver Block Diagram (UHF2 and 700–800 MHz)

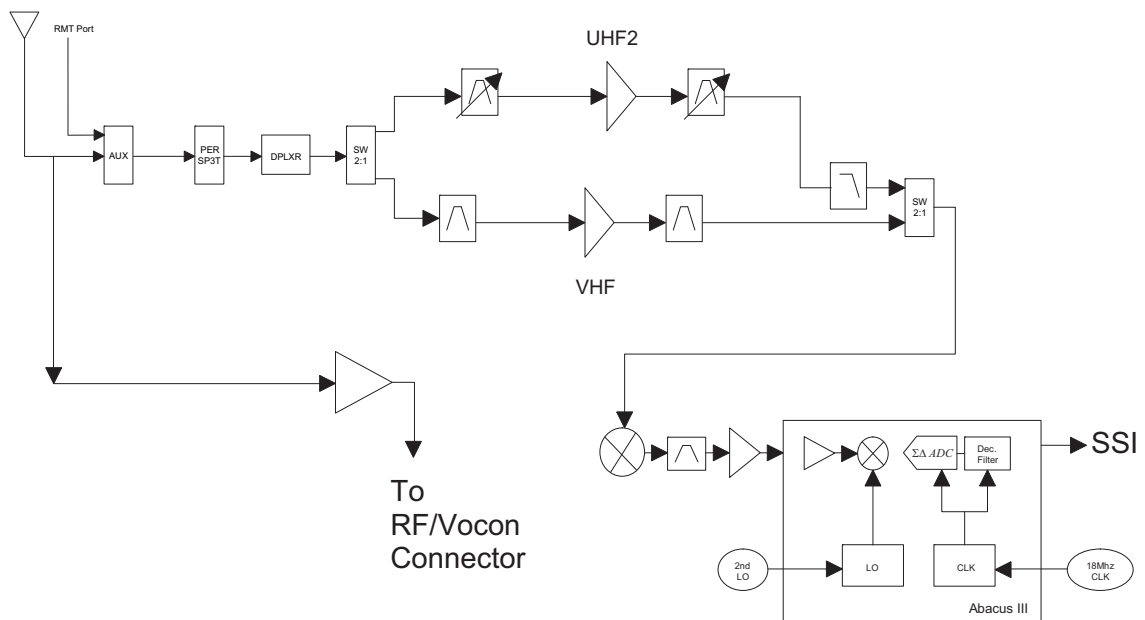

Figure 3-8. Receiver Block Diagram (UHF2 and VHF)

### 3.2.1.1 GPS

The GPS architecture employs a single chip GPS receiver which decodes GPS signals at 1575.42 MHz. It is capable of producing a final position solution including full tracking and data decode capability. The GPS receiver will operate in the autonomous mode only.

The GPS signal is tapped at the antenna port via a series resonant network which provides a very low capacitive load to the transceiver. The signal is routed through a GPS LNA and its output is applied to the RF-Controller interface connector where it is eventually routed to the expansion board for processing by the GPS IC.

The GPS receiver is setup in an autonomous one track always (OTA) mode, also known as continuous navigation. This means the GPS will continuously track satellites for as long as the radio is powered to ensure the best possible accuracy. In the event the radio loses visibility of the satellites due to terrain or environmental factors such as driving through a tunnel or entering a building, the GPS will temporarily lose its position fix. A power savings algorithm will then cycle the GPS in and out of a sleep mode at approximately 90 second intervals until the radio has moved back into an environment where GPS signals are present.

The user will be able to view the current latitude, longitude, and time/date stamp on the radio's display. The radio can also be configured to send its location to the system at predetermined intervals (LRRP). Depending on system options, the user may be able to enable/disable the GPS receiver.

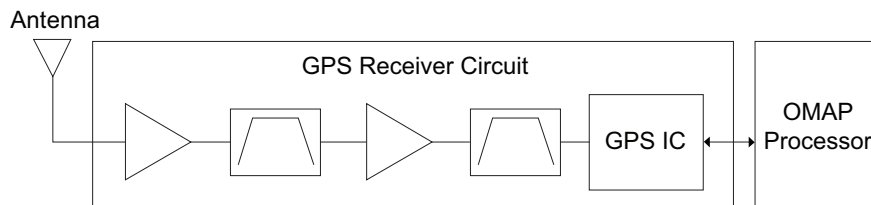

Figure 3-9. GPS Diagram

### 3.2.1.2 VHF Front-End

From the first band select switch, a VHF signal is routed to the first pre-selector filter followed by an LNA and a second pre-selector filter. Both filters are discrete and fixed designs and are used to band limit the incoming energy and suppress known spurious responses such as Image and the  $\frac{1}{2}$  IF spur. The output of the second pre-selector filter is applied to the RF port of the Mixer IC via a second VHF/700,800 or VHF/UHF1, or VHF/UHF2 band select switch. The Mixer IC is also excited by a Local Oscillator (LO) signal at the LO port to down-convert the RF signal to a 109.65 MHz intermediate frequency (IF). The down converted IF signal is passed through a crystal filter and IF amplifier which drives the input of the Abacus 3 Analog to Digital Converter IC (AD9864).

### 3.2.1.3 700/800 MHz Front-End

From the first band select switch, a 700 MHz or 800 MHz band signal is routed to a second band SPST switch which selects the 700 or the 800 band signal and routes it to the appropriate first pre-selector filter. A third band select switch selects the output of the appropriate filter and applies it to an LNA followed by a similar pre-selector filter/ band-select switch circuit. The signal is then routed to second LNA whose output is applied to a discrete image filter. Both preselector filters are Surface Acoustic Wave designs used to band limit the received energy and suppress known spurious responses such as Image and the  $\frac{1}{2}$  IF spur. The output of the discrete image filter is applied to the RF port of the Mixer IC via a second VHF/700,800 or UHF1/700,800 or UHF2/700,800 band select switch. The Mixer IC is also excited by a Local Oscillator (LO) signal at the LO port to down-convert the RF signal to a 109.65 MHz intermediate frequency (IF). The down converted IF signal is passed through a crystal filter and IF amplifier which drives the input of the Abacus 3 Analog to Digital Converter IC (AD9864).

### 3.2.1.4 UHF1 Front-End

From the first band select switch, a UHF1 signal is routed to the first pre-selector filter followed by an LNA and a second pre-selector filter. Both filters are discrete and tunable designs and are used to band limit the incoming energy and suppress known spurious responses such as Image spur. The output of the second pre-selector filter is applied to the RF port of the Mixer IC via a second UHF1/700,800 or UHF1/VHF or UHF1/UHF2 band select switch. The Mixer IC is also excited by a Local Oscillator (LO) signal at the LO port to down-convert the RF signal to a 109.65 MHz intermediate frequency (IF). The down converted IF signal is passed through a crystal filter and IF amplifier which drives the input of the Abacus 3 Analog to Digital Converter IC (AD9864).

### 3.2.1.5 UHF2 Front-End

From the first band select switch, a UHF2 signal is routed to the first pre-selector filter followed by a Low Noise Amplifier (LNA) and a second pre-selector filter. Both filters are discrete and tunable designs and are used to band limit the incoming energy and suppress known spurious responses such as Image spur. The output of the second pre-selector filter is applied to a discrete Low Pass Filter (LPF). The output of the LPF is applied to the RF port of the Mixer IC via a second UHF2/700,800 or UHF1/UHF2 or VHF/UHF2 band select switch. The Mixer IC, is driven by a Local Oscillator (LO) signal generated by the Trident synthesizer IC, at the LO port to down-convert the RF signal to a 109.65 MHz intermediate frequency (IF). It is a passive, high linearity design with balanced inputs at the RF and IF ports and internal LO buffer. The down converted IF signal is passed through a 3-pole crystal filter, and an IF amplifier, which drives the input of the Analog to Digital Converter IC.

### 3.2.1.6 Analog To Digital Converter

The ADC IC's front end down converts the first IF to a second IF, a 2.25 MHz signal. The second IF is sampled at 18 MHz, a signal generated by an integrated clock synthesizer. The sampled signal is decimated by a factor of 900 to 20 kHz and converted to SSI format at the ADC's output. The Serial Synchronous Interface (SSI) serial data waveform is composed of a 16 bit in-phase word (I) followed by a 16 bit Quadrature word (Q). A 20 kHz Frame Synch and a 1.2 MHz clock waveform are used to synchronize the SSI IQ data transfer to the Digital Signal Processor IC (OMAP) for post-processing and demodulation.

### 3.2.2 Transmitting

When the radio is transmitting, microphone audio is digitized and then processed by the DSP and sent to the Trident IC (see Figure 3-10 to Figure 3-15) via the SSI interface. The Trident IC processes the SSI data for application to the voltage controlled oscillator as a modulation signal.

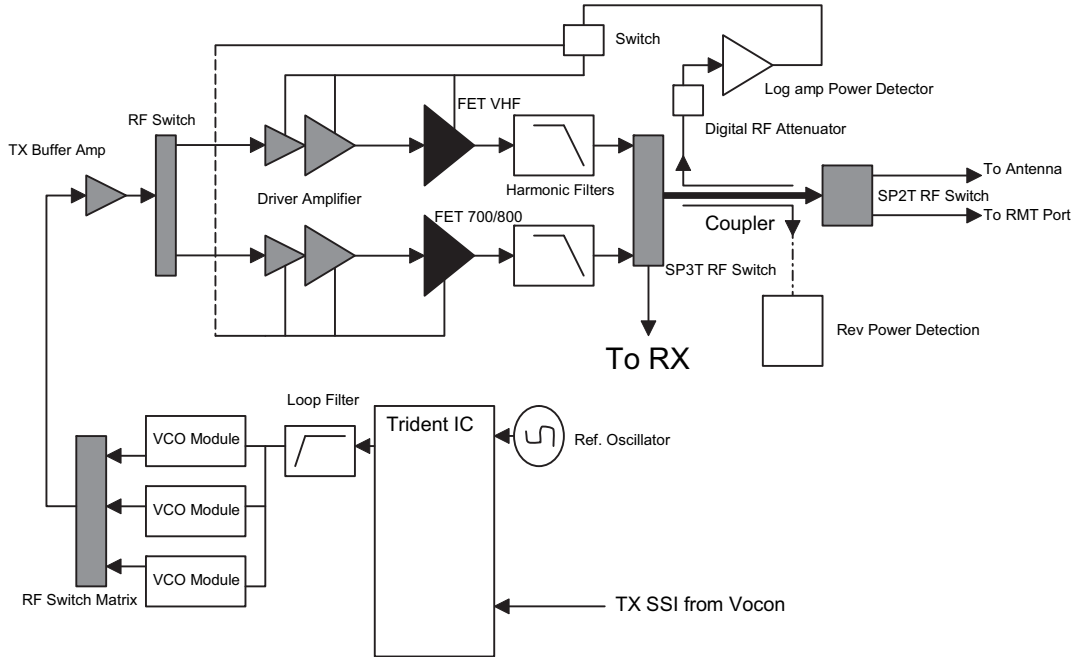

Figure 3-10. Transceiver (VHF and 700–800 MHz) Block Diagram

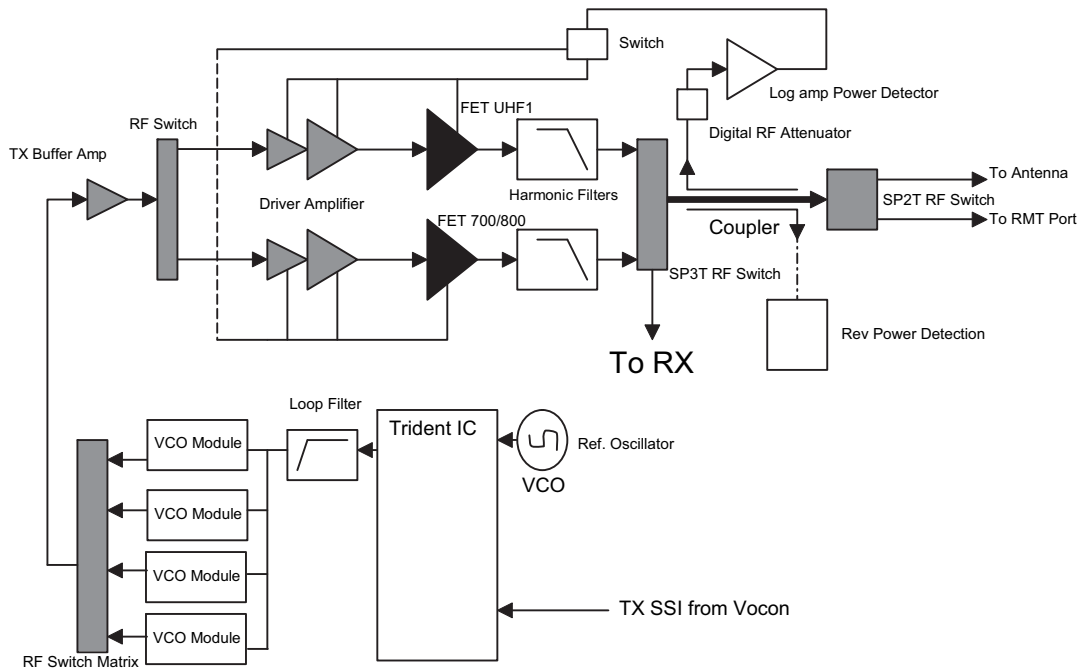

Figure 3-11. Transceiver (UHF1 and 700–800 MHz) Block Diagram

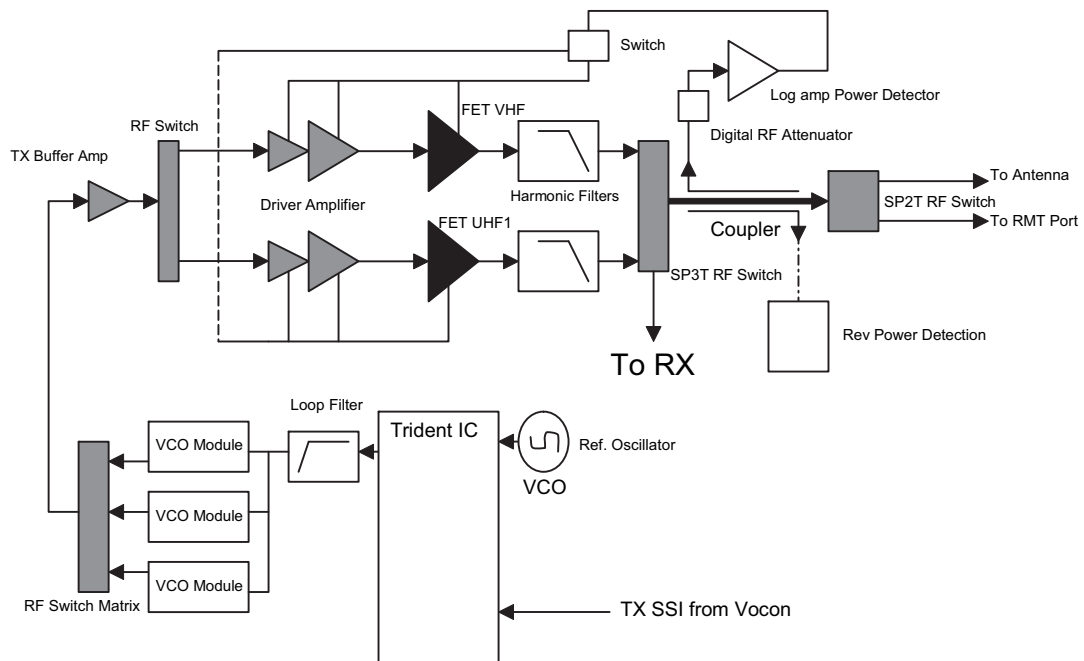

Figure 3-12. Transceiver (VHF and UHF1) Block Diagram

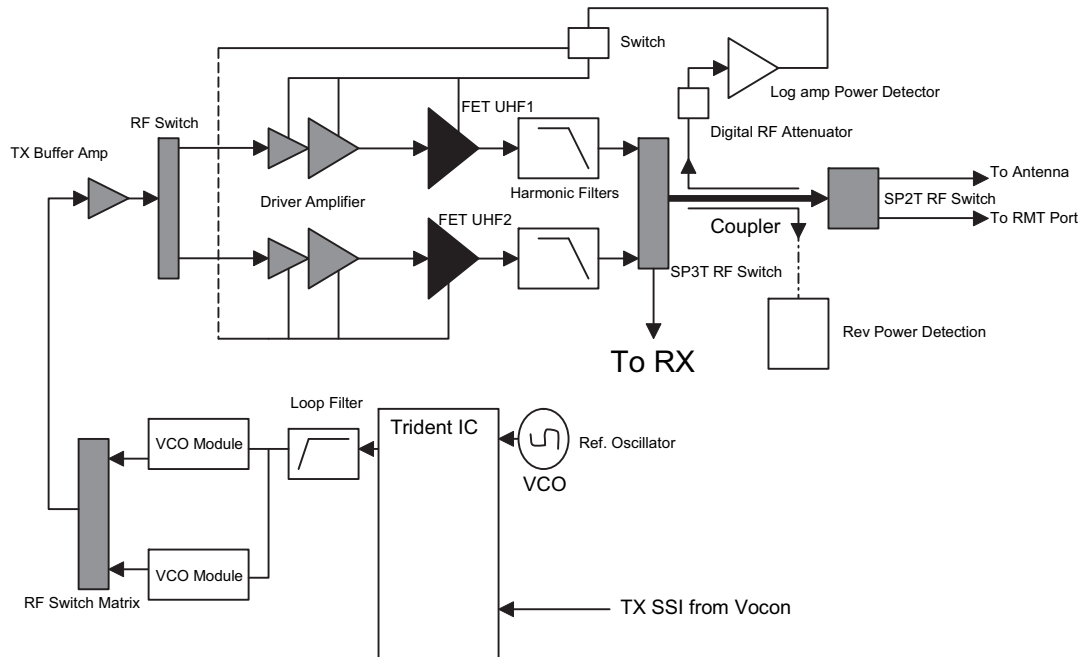

Figure 3-13. Transceiver (UHF1 and UHF2) Block Diagram

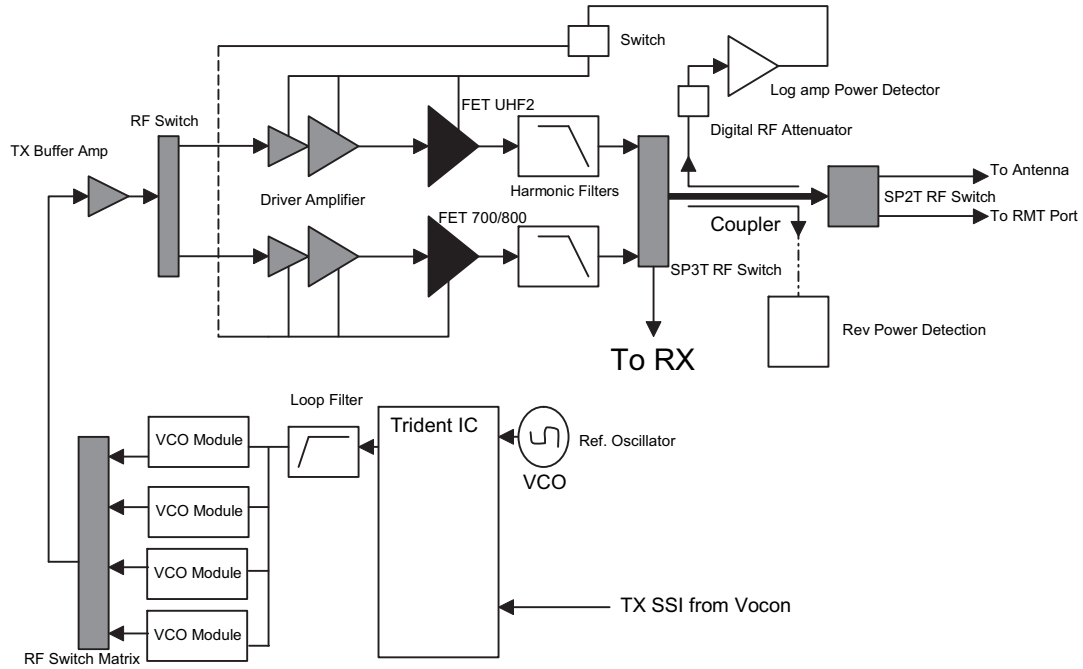

Figure 3-14. Transceiver (UHF2 and 700–800 MHz) Block Diagram

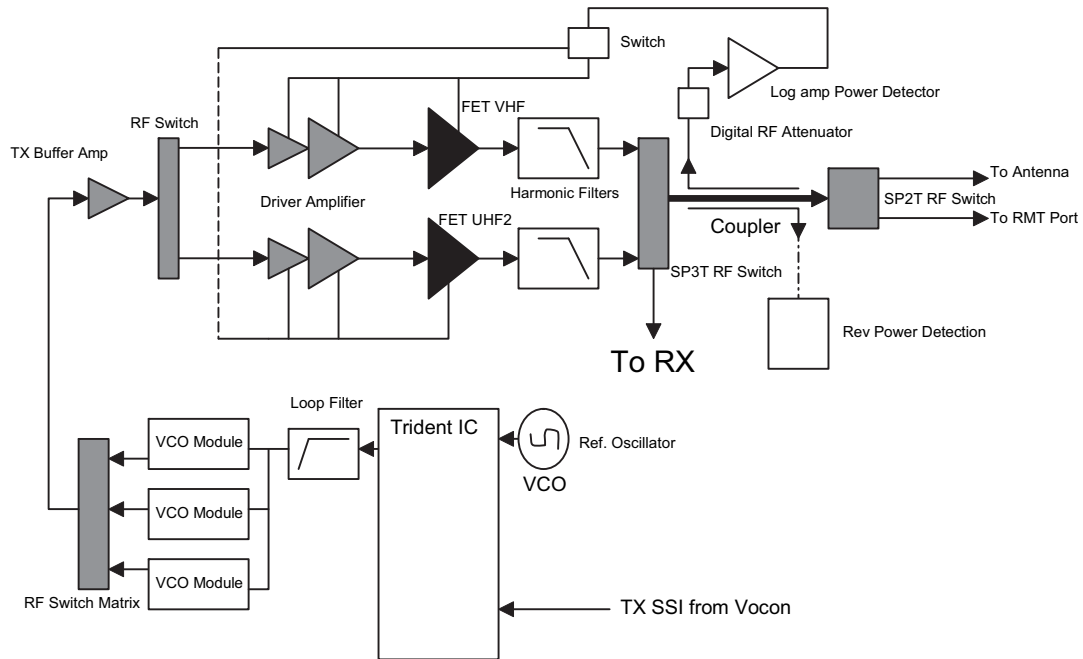

Figure 3-15. Transceiver (VHF and UHF2) Block Diagram

### 3.2.2.1 VHF Transmit

Once a VHF frequency for transmit has been selected, the Trident IC and its accompanying logic circuitry enable the correct voltage controlled oscillator which then generates the desired transmit frequency. This transmit signal is then routed to the TX buffer amplifier which amplifies the signal. An RF switch then routes the signal to the VHF Driver amplifier and then to the discrete final stage. The signal is then filtered by a harmonic filter and passed through a RF switch into a directional coupler. The Log Amp power detector monitors the output of the directional coupler and adjusts the control voltages to the driver amplifier and the discrete final. Finally, the RF signal comes to a Single Pole DoubleThrow (SP2T) RF switch which can route the power to the main antenna or to the Universal Connector port of the radio.

### 3.2.2.2 700/800 MHz Transmit

Once a 700/800 MHz frequency for transmit has been selected, the Trident IC and its accompanying logic circuitry enable the correct voltage controlled oscillator which then generates the desired transmit frequency. This transmit signal is then routed to the TX buffer amplifier which amplifies the signal. An RF switch then routes the signal to the 700/800 MHz Driver amplifier and then to the discrete final stage. The signal is then filtered by a harmonic filter and passed through a RF switch into a directional coupler. The Log Amp power detector monitors the output of the directional coupler and adjusts the control voltages to the driver amplifier and the discrete final. Finally, the RF signal comes to a Single Pole Double Throw (SP2T) RF switch which can route the power to the main antenna or to the Universal Connector port of the radio.

### 3.2.2.3 UHF1 Transmit

Once a UHF frequency for transmit has been selected, the Trident IC and its accompanying logic circuitry enable the correct voltage controlled oscillator which then generates the desired transmit frequency. This transmit signal is then routed to the TX buffer amplifier which amplifies the signal. An RF switch then routes the signal to the UHF1 Driver amplifier and then to the discrete final stage. The signal is then filtered by a harmonic filter and passed through a RF switch into a directional coupler. The Log Amp power detector monitors the output of the directional coupler and adjusts the control voltages to the driver amplifier and the discrete final. Finally, the RF signal comes to a Single Pole DoubleThrow (SP2T) RF switch which can route the power to the main antenna or to the Universal Connector port of the radio.

### 3.2.2.4 UHF2 Transmit

Once a UHF frequency for transmit has been selected, the Trident IC and its accompanying logic circuitry enable the correct voltage controlled oscillator which then generates the desired transmit frequency. This transmit signal is then routed to the TX buffer amplifier which amplifies the signal. An RF switch then routes the signal to the UHF2 Driver amplifier and then to the discrete final stage. The signal is then filtered by a harmonic filter and passed through a RF switch into a directional coupler. The Log Amp power detector monitors the output of the directional coupler and adjusts the control voltages to the driver amplifier and the discrete final. Finally, the RF signal comes to a Single Pole DoubleThrow (SP2T) RF switch which can route the power to the main antenna or to the Universal Connector port of the radio.

## 3.3 Digital (ASTRO) Mode of Operation

In the ASTRO (digital) mode of operation, the transmitted or received signal is limited to a discrete set of frequency deviation levels. The receiver handles an ASTRO-mode signal identically to an analog-mode signal, up to the point where the DSP decodes the received data. In the ASTRO receive mode, the DSP uses a different algorithm to recover data.

In the ASTRO transmit mode, microphone audio is processed identically to an analog mode, with the exception of the algorithm the DSP uses to encode the information. Using this algorithm, transmitter FM deviation is limited to discrete levels.

### 3.4 Controller Section

The controller section (see Figure 3-16) comprises of five functional sections that are split among three boards, which are the VOCON, EXPANSION and BLUETHOOTH OPTION boards. The main functional section consists of a dual core ARM and DSP controller, an encryption processor (MACE), Flash memory, and a Double Data Rate Synchronous Dynamic Random Access Memory (DDR SDRAM). The Power and Clocks section includes a power management IC (MAKO) and various external switching regulators, and two clock sources (12 MHz and 24.576 MHz) from which all other controller digital clocks are derived. The Audio section has a CODEC and a class-D audio power amplifier that provides the radio with a multiple microphone, multiple speaker design. The User Interface section provides communication and control to the top and main Liquid Crystal Displays (LCD) on the radio, as well as a keypad and a side connector interface conforming to Universal Connector specifications. The Expansion Memory, GPS and Bluetooth section comprises of a Micro SD memory interface, Global Positioning Satellite (GPS) processor, and an Option Board for radio feature upgrades.

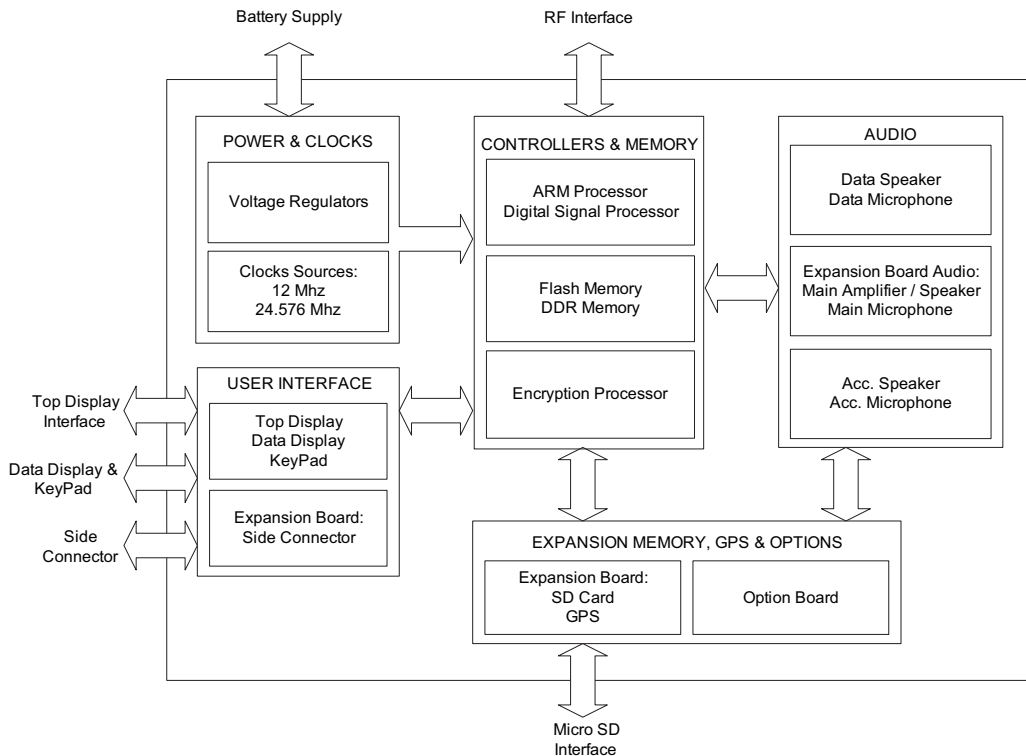

Figure 3-16. Controller Block Diagram

The ARM controller core of the OMAP processor handles the power up sequence of all devices, including firmware upgrades, and all operating system tasks that are associated with FLASH and SDRAM memories and user interface communication. The FLASH memory (64 MB) is required to store the firmware, tuning, and Codeplug settings, which upon initialization get read and stored into SDRAM (32 MB) for execution. The ARM and DSP core jointly control and configure audio, wireless and RF devices linked to the Serial Peripheral Interface (SPI) and Synchronous Serial Interface (SSI) buses to enable radio FM and optional wireless communication protocols. For encryption, a separate ARM processor is used (MACE) to encode and decode encryption packets coming in from the main OMAP processor through the SSI interface. Its firmware is flashed via the main processor during an upgrade request to its internal FLASH memory.



The power and most clocks to the controller devices are provided by the MAKO IC and external switching and linear regulators on board. A Complex Programmable Logic Array (CPLD) IC divides the 24.576 MHz clock from MAKO to source OMAP's 32 kHz Real Time Clock, and MACE's 4 MHz main clock. OMAP's main clock is supplied externally from an on board 12 MHz crystal.

The radio has two internal microphones and two internal speakers, as well as available microphone and speaker connections for external accessories. The main external speaker is located opposite to the main display and keypad of the radio. It can deliver a rated power of 1W on a ~4 Ohms speaker, while the smaller "data" speaker can only deliver 0.5 W of power on a load of 16 Ohms. Both internal and external microphones use the CODEC's AD to deliver digital audio samples to the DSP controller. The main speaker is driven by the class D PA on the expansion board, while the data and external speakers are driven by the AB type PA on MAKO. Both speaker paths use the CODEC for volume control and to convert audio from digital to analog.

The user interface block consists of a top and main or "data side" display, a keypad, top controls and the accessory side connector. The side connector (Universal Connector) provides audio, USB, RS232 and RF communication for accessories. All signals to and from the connector go through the internal expansion board before reaching the microcontroller and other devices on the main board.

The radio also has an expansion bay for a Micro SD memory card, a Global Positioning System (GPS) interface, and an bluetooth slot for radio feature upgrades. The memory card can be inserted on the bay near the battery connector of the radio. The bluetooth slot of the radio is available internally to the radio, and it is not hot swappable by the user. The bluetooth slot is available through a connector directly linked to the main controller board.

## Notes

# Chapter 4 Recommended Test Equipment and Service Aids

This chapter provides lists of recommended test equipment and service aids, as well as information on field programming equipment that can be used in servicing and programming ASTRO APX 7000 radios.

## 4.1 Recommended Test Equipment

The list of equipment contained in [Table 4-1](#) includes all of the standard test equipment required for servicing two-way portable radios, as well as several unique items designed specifically for servicing this family of radios. The “Characteristics” column is included so that equivalent equipment may be substituted; however, when no information is provided in this column, the specific Motorola model listed is either a unique item or no substitution is recommended.

*Table 4-1. Recommended Test Equipment*

Equipment	Characteristics	Example	Application
Service Monitor	Can be used as a substitute for items marked with an asterisk (*)	Aeroflex 3920 ( <a href="http://www.aeroflex.com">www.aeroflex.com</a> ), R-2670 Communication Analyzer, 8901_ Modulation Analyzer ( <a href="http://www.agilent.com">www.agilent.com</a> ) or equivalent	Frequency/deviation meter and signal generator for wide-range troubleshooting and alignment
Digital RMS Multimeter *	100 $\mu$ V to 300 V 5 Hz to 1 MHz 10 Mega Ohm Impedance	Fluke 179 or equivalent ( <a href="http://www.fluke.com">www.fluke.com</a> )	AC/DC voltage and current measurements. Audio voltage measurements
RF Signal Generator *	100 MHz to 1 GHz -130 dBm to +10 dBm FM Modulation 0 kHz to 10 kHz Audio Frequency 100 Hz to 10 kHz	Agilent N5181A ( <a href="http://www.agilent.com">www.agilent.com</a> ), Ramsey RSG1000B ( <a href="http://www.ramseyelectronics.com">www.ramseyelectronics.com</a> ), or equivalent	Receiver measurements
Oscilloscope *	2 Channel 50 MHz Bandwidth 5 mV/div to 20 V/div	Leader LS8050 ( <a href="http://www.leaderusa.com">www.leaderusa.com</a> ), Tektronix TDS1001b ( <a href="http://www.tektronix.com">www.tektronix.com</a> ), or equivalent	Waveform measurements
RF Millivolt Meter	100 mV to 3 V RF 10 kHz to 1 GHz	Boonton 9240 ( <a href="http://www.boonton.com">www.boonton.com</a> ) or equivalent	Waveform measurements
Power Supply	0 V to 32 V 0 A to 20 A	B&K Precision 1790 ( <a href="http://www.bkprecision.com">www.bkprecision.com</a> ) or equivalent	Voltage supply

## 4.2 Service Aids

Refer to [Table 4-2](#) for a listing and description of the service aids designed specifically for servicing this family of radios. These kits and/or parts are available from the Radio Products and Solutions Organization offices listed in [“Appendix B. Replacement Parts Ordering”](#) on page B-1. While all of these items are available from Motorola, most are standard shop equipment items, and any equivalent item capable of the same performance may be substituted for the item listed.

Table 4-2. Service Aids

Motorola Part Number	Description	Application
1110027B23	Speaker Module Seal Lubricant	Used to ensure good sealing of the Speaker Module to the Main Chassis.
5880384G68	SMA to BNC Adapter	Adapts radio's antenna port to BNC cabling of test equipment.
66009254001	APX 7000/ APX 7000XE Battery Eliminator	Used in place of battery to connect radio to an external power supply.
66009255001	Grille Eliminator	Special tool used when pressure testing the radio. Replaces the radio grille to seal the port vent.
66009256001	Volume Potentiometer Outer Spanner Bit	Used to assemble and disassemble the spanner nut on the volume potentiometer.
66009258001	Antenna Spanner Bit	Used to assemble and disassemble the spanner nut on the antenna bushing.
66009259001	Vacuum Adapter	Submersible radios only. Connects the vacuum/pressure hose to the radio.
66009260001	Board Analysis Fixture (APX 7000)	Special fixture that allows radio's internal board to be mounted externally. Provides easy access to electronic circuits, required for board-level troubleshooting.  <b>NOTE:</b> Contact Motorola Solutions Radio Products and Solutions Organization (1-800-927-2744) to determine which version of fixture is required for your APX 7000 radio.
66009260003	Board Analysis Fixture (APX 7000XE and future APX 7000)	
NLN9839_	Vacuum Pump Kit	Submersible radios only. Vacuum pump with gauge and vacuum hose. Requires 66009259001 Adapter Kit.
NTN4265_	Pressure Pump Kit	Submersible radios only. Pressure pump with gauge and pressure hose. Requires 66009259001 Adapter Kit.
RVN5224_	Customer Programming Software (CPS) and Tuner Software	CPS allows customer-specific programming of modes and features. Tuner software required to perform alignment of radio parameters.
PMKN4012_	Programming Cable	Used to program the radio through Customer Programming Software and Tuner Software.
PMKN4013_	Programming/Service Cable	Used to program and service the radio through Customer Programming Software and Tuner Software.
RLN4460_	Portable Test Set	Used for radio performance checks. Connects to radio's universal connector and allows remote switching and signal injection/outputs for test equipment measurements.

## **4.3 Field Programming**

This family of radios can be aligned and programmed in the field. This requires specific equipment and special instructions. Refer to the online help in the Customer Programming Software (CPS) for complete field programming information.

## Notes

# Chapter 5 Performance Checks

This chapter covers performance checks used to ensure that the ASTRO APX 7000 radio meets published specifications. The recommended test equipment listed in the previous section approaches the accuracy of the manufacturing equipment, with a few exceptions. Accuracy of the test equipment must be maintained in compliance with the manufacturer's recommended calibration schedule. Checks should be performed if radio performance degradation is suspected.

## 5.1 Test Equipment Setup

Supply voltage can be connected from the battery eliminator. The equipment required for the performance checks is connected as shown in [Figure 5-1](#).

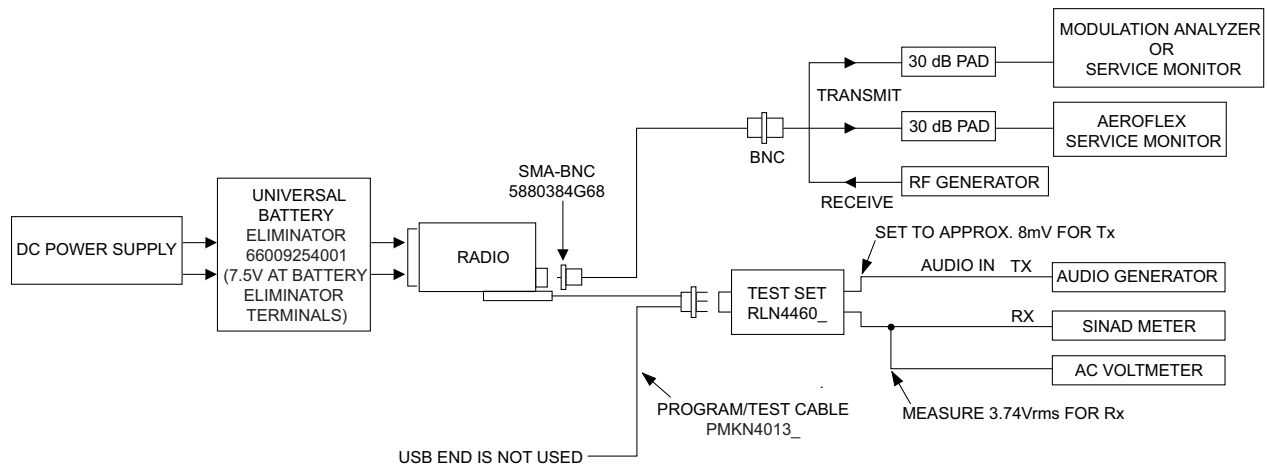

Figure 5-1. Performance Checks Test Setup

Initial equipment control settings should be as indicated in [Table 5-1](#) and should be the same for all performance checks and alignment procedures, except as noted.

Table 5-1. Initial Equipment Control Settings

System Analyzer	Test Set	Power Supply
<b>Monitor Mode:</b> Standard*	<b>Spkr/Load:</b> Speaker	<b>Voltage:</b> 7.5 Vdc
Receiver Checks <b>RF Control:</b> GEN <b>Output Level:</b> -47 dBm <b>Modulation:</b> 1 kHz tone @3 kHz deviation for 25 kHz channel spacing @1.5 kHz deviation for 12.5 kHz channel spacing <b>Frequency:</b> Set to selected radio RX frequency <b>Meter:</b> AC Volts  Transmitter Checks <b>RF Control:</b> MONITOR <b>Frequency:</b> Set to selected radio TX frequency <b>Meter:</b> RF Display <b>Modulation Type:</b> FM <b>Attenuation:</b> 20 dB	<b>PTT:</b> OFF (center)	<b>DC On/Standby:</b> Standby
	<b>Meter Out:</b> RX	<b>Volt Range:</b> 10 Vdc
	<b>Opt Sel:</b> ON	<b>Current:</b> 2.5 Amps

\* Use "PROJ 25 STD" if testing ASTRO Conventional channels.



## 5.2 Display Radio Test Mode (Dual-Display Version)

This section provides instructions for performing tests in display radio test mode.

### 5.2.1 Access the Test Mode

To enter the display radio test mode:

1. Turn the radio on.
2. Within 10 seconds after "SELF TEST" is complete, press **Side Button 2** five times in succession.

The radio shows a series of displays that give information regarding various version numbers and subscriber specific information. The displays are described in [Table 5-2](#).

*Table 5-2. Test-Mode Displays*

Name of Display	Description	Appears
<b>Service</b>	The literal string indicates the radio has entered test mode.	Always
<b>Host version</b>	The version of host firmware is displayed.	Always
<b>DSP version</b>	The version of DSP firmware is displayed.	Always
<b>Secure version</b>	Version of the encryption software	When the radio is secure equipped
<b>KG1</b> algorithms name (Encryption Type 1)	Type of encryption being used	When the radio is secure equipped
<b>KG2</b> algorithms name (Encryption Type 2)	Type of encryption being used	When the radio is secure equipped and 2 or more algorithms are loaded
<b>KG3</b> algorithms name (Encryption Type 3)	Type of encryption being used	When the radio is secure equipped and 3 or more algorithms are loaded
<b>KG4</b> algorithms name (Encryption Type 4)	Type of encryption being used	When the radio is secure equipped and 4 or more algorithms are loaded
<b>KG5</b> algorithms name (Encryption Type 5)	Type of encryption being used	When the radio is secure equipped and 5 or more algorithms are loaded
<b>Model number</b>	The radio's model number, as programmed in the codeplug	Always
<b>Serial number</b>	The radio's serial number, as programmed in the codeplug	Always
<b>ESN</b>	The radio's unique electronic serial number	Always
<b>ROM Size</b>	The memory capacity of the host FLASH part	Always

Table 5-2. Test-Mode Displays (Continued)

Name of Display	Description	Appears
FLASHcode	The FLASH codes as programmed in the codeplug	Always
RF band 1	The radio's operating frequency	Always
RF band 2	The radio's operating frequency	When the radio has more than 1 operating frequency
Tuning ver	Version of Tuning codeplug	Always
Proc ver	Version of Processor	Always
Option Board Type	Type of Option Board in the radio	When the radio is equipped with an Option Board
Option Board Bluetooth Addr	Address of the Bluetooth IC	When the radio is equipped with a Bluetooth Option Board
Option Board SW Version	Version of Option Board software	When the radio is equipped with an Option Board

**NOTE:** All displays are temporary and will expire without any user intervention. If information is longer than the physical length of the radio's display, the information will wrap around to the next display. After the last display, "RF TEST" is displayed.

To freeze any of the displays, press the left arrow on the 4-Way Navigation Button. To resume automatic scrolling, press the right arrow on the 4-Way Navigation Button. To rapidly scroll forward through the displays, continue pressing the right arrow. You cannot scroll backwards.

**NOTE:** Press the Top side (purple) button to advance the test environments from "RF TEST", "CH TEST", "RGB TEST", "CID TEST" then press the orange button to confirm selection. Press any other buttons to advance the test.

Once a test is carried out, restart the radio to proceed to another test.

3. Do one of the following:

- Press the **Top Side Button** to stop the displays and toggle between RF test mode and the Control Top and Keypad test mode. The test mode menu "CH TEST" is displayed, indicating that you have selected the Control Top and Keypad test mode. Go to Section "5.2.3 Control Top and Keypad Test Mode" on page 1:5-6.

**NOTE:** Each press of the **Top Side Button** will toggle between "CH TEST" and "RF TEST".

- Press the **Top Button** (Orange button) to stop the displays and put the radio into the RF test mode. The test mode menu, "1 CSQ", is displayed, indicating test frequency 1, Carrier Squelch mode. Go to Section "5.2.2 RF Test Mode" below.

**NOTE:** Once your radio is in a particular test mode, you must turn off the radio and turn it back on again to access the other test mode.

## 5.2.2 RF Test Mode

When the ASTRO APX 7000 radio is operating in its normal environment, the radio's microcomputer controls the RF channel selection, transmitter key-up, and receiver muting, according to the customer codeplug configuration. However, when the unit is on the bench for testing, alignment, or repair, it must be removed from its normal environment using a special routine, called **RF TEST MODE**.

While in RF test mode:

- Each additional press of **Side Button 2** advances to the next test channel. (Refer to [Table 5-3](#).)
- Pressing **Side Button 1** scrolls through and accesses the test environments shown in [Table 5-4](#).

**NOTE:** Transmit into a load when keying a radio under test.

Table 5-3. Test Frequencies (MHz)

Test Channel	VHF		UHF1		UHF2		700–800 MHz	
	RX	TX	RX	TX	RX	TX	RX	TX
F1	136.075	136.025	380.075	380.025	450.075	450.025	764.0625	764.0125
F2	142.075	142.125	390.075	390.025	460.075	460.025	769.0625	769.0125
F3	154.275	154.225	400.075	400.025	471.075	471.025	775.9375	775.9875
F4	160.175	160.125	411.075	411.025	484.925	484.975	851.0625	794.0125
F5	168.125	168.075	424.975	424.925	485.075	485.025	860.0625	809.0125
F6	173.925	173.975	435.075	435.025	495.075	495.025	869.9375	823.9875
F7	–	–	444.925 (Tune) / 445.075 (Test Mode)	444.975 (Tune) / 444.999995 (Test Mode)	506.075	506.025	851.0625	851.0125
F8	–	–	445.075	445.025 (Tune) / 445.000005 (Test Mode)	519.925	519.975	860.0625	860.0125
F9	–	–	457.075	457.025	–	–	869.9375	869.8875
F10	–	–	469.975	469.925	–	–	–	–

Table 5-4. Test Environments

Display	Description	Function
<b>CSQ</b>	Carrier Squelch	RX: unsquelch if carrier detected TX: mic audio
<b>TPL</b>	Tone Private-Line	RX: unsquelch if carrier and tone (192.8 Hz) detected TX: mic audio + tone (192.8 Hz)
<b>SEC</b>	Secure**	RX: auto-coded clear TX: with key present–encrypted audio with key absent–constant unsquelch

Table 5-4. Test Environments (Continued)

Display	Description	Function
AST	ASTRO	RX: none TX: Digital Voice***
USQ	Carrier Unsquench	RX: unsquelch always TX: mic audio

\*\* On radios equipped with secure option.

\*\*\*All deviation values are based on deviation tuning of this mode.

### 5.2.3 Control Top and Keypad Test Mode

This test mode is used to verify proper operation of all radio buttons and switches if a failure is suspected.

#### 5.2.3.1 Control Top Checks







To perform the control top checks:

1. Press and hold the **Top Button** (Orange button); the radio icons are displayed, and the LED lights amber.
2. Release the **Top Button**; "148/0" appears, which indicates that the **Top Button** is in the open position. Your radio is now in the Control Top and Keypad test mode.
3. Press the **Top Button** again; "148/1" appears, which indicates that the **Top Button** is in the closed position.
4. Rotate the **16-Position Select Switch**; "4/0" through "4/15" appears, which indicates that the selector switch is in mode/zone position 1 through 16.
5. Rotate the **Two-Position Concentric Switch**; "65/0" and "65/1" appear.
6. Cycle through the **Three-Position A/B/C Switch**; "67/0," "67/1," and "67/2" appear.
7. Rotate the **Volume Control**; "2/0" through "2/255" appear. The display values may vary slightly at the upper and lower limits.
8. Press the **Top Side Button**; "96/1" appears; release, "96/0" appears.
9. Press **Side Button 1**; "97/1" appears; release, "97/0" appears.
10. Press **Side Button 2**; "98/1" appears; release, "98/0" appears.
11. Press the **PTT Button**; "1/1" appears; release, "1/0" appears.

#### 5.2.3.2 Keypad Checks:

To continue to the keypad checks:

##### 5.2.3.2.1 Dual-Display Model

- Press , "48/1" appears; release, "48/0" appears.
- Press , "49/1" appears; release, "49/0" appears.
- Press , "50/1" appears; release, "50/0" appears.
- Press , "51/1" appears; release, "51/0" appears.
- Press , "52/1" appears; release, "52/0" appears.
- Press , "53/1" appears; release, "53/0" appears.

- Press , "54/1" appears; release, "54/0" appears.
- Press , "55/1" appears; release, "55/0" appears.
- Press , "56/1" appears; release, "56/0" appears.
- Press , "57/1" appears; release, "57/0" appears.
- Press , "58/1" appears; release, "58/0" appears.
- Press , "59/1" appears; release, "59/0" appears.
- Press , "128/1" appears; release, "128/0" appears.
- Press , "129/1" appears; release, "129/0" appears.
- Press , "130/1" appears; release, "130/0" appears.
- Press , "131/1" appears; release, "131/0" appears.
- Press , "132/1" appears; release, "132/0" appears.
- Press , "133/1" appears; release, "133/0" appears.
- Press , "134/1" appears; release, "134/0" appears.
- Press , "135/1" appears; release, "135/0" appears.
- Press , "136/1" appears; release, "136/0" appears.

## 5.3 Top-Display Version Radio Test Mode

This section provides instructions for performing tests in non-display radio test mode.

### 5.3.1 Access the Test Mode

To enter the non-display radio test mode:

1. Turn the radio on.
2. Within 10 seconds after the top red LED turns off, press **Side button 2** five times in succession.
3. Do one of the following:
  - Press the **Top Side Button** to put the radio into the Control Top and Keypad test mode. Go to ["5.3.3 Control Top Test Mode"](#) below.
  - NOTE:** Each press of the **Top Side Button** toggles between Control Top and Keypad test mode (non-display radio) and RF test mode (non-display radio).
  - Press the **Top Button** (Orange button) to put the radio into the RF test mode. Go to ["5.3.2 RF Test Mode"](#) below.

### 5.3.2 RF Test Mode

When the ASTRO APX 7000 radio is operating in its normal environment, the radio's microcomputer controls the RF channel selection, transmitter key-up, and receiver muting, according to the customer codeplug configuration. However, when the unit is on the bench for testing, alignment, or repair, it must be removed from its normal environment via a special routine, called **RF TEST MODE**.

While in RF test mode:

- Each additional press of **Side Button 2** advances to the next test channel. (Refer to [Table 5-3 on page 1:5-5](#)) The channel number is represented by the number of tones emitted by the radio after the button press (for example, five tones indicates channel 5).
- Pressing **Side Button 1** scrolls through and accesses test environments shown in [Table 5-4 on page 1:5-5](#). The test environment is represented by the number of tones emitted by the radio after the button press (for example, 11 tones indicate AST).

**NOTE:** Transmit into a load when keying a radio under test.

### 5.3.3 Control Top Test Mode

This test mode is used to verify proper operation of all radio buttons and switches if a failure is suspected.

To perform the control top checks:

1. Press and hold the **Top Button** (Orange button); the LED lights red, and the radio beeps.
2. Release the **Top Button**; the radio beeps, indicating that the **Top Button** is in the open position.
3. Press the **Top Button** again; the radio beeps, indicating that the **Top Button** is in the closed position.
4. Rotate the **Two-Position Concentric Switch**; the radio beeps in each switch position.
5. Rotate the **16-Position Select Switch**; the radio beeps in each switch position.
6. Cycle through the **Three-Position A/B/C Switch**; the radio beeps in each switch position.
7. Rotate the **Volume Control**; the radio beeps at each new volume setting.
8. Press the **Top Side Button**; the radio beeps.
9. Press **Side Button 1**; the radio beeps.
10. Press **Side Button 2**; the radio beeps.

## 5.4 Receiver Performance Checks

The following tables outline the performance checks for the receiver.

Table 5-5. Receiver Performance Checks

Test Name	System Analyzer	Radio	Test Set	Comments
Rated Audio	<b>RF Control:</b> Gen <b>Output Level:</b> -47 dBm <b>Freq:</b> Selected radio RX freq. <b>Mod:</b> 1 kHz tone @ 3 kHz dev. <b>Meter:</b> AC Volts	As above	<b>PTT</b> to OFF (center)	Set volume control to 3.74 Vrms
Distortion	As above, except <b>Meter:</b> Ext Dist.	As above	As above	Distortion < 3.0%
Sensitivity (SINAD)	As above, except <b>Meter:</b> SINAD	As above	As above	RF input to be < 0.35 $\mu$ V
Noise Squelch Threshold (only radios with conventional system need to be tested)	Set as for rated audio check	Out of TEST MODE; select a conventional system	As above	Set volume control to 3.74 Vrms. Set RF level to -130 dBm and raise until radio unsquelches. Unsquelch to occur at < 0.25 $\mu$ V. Preferred SINAD = 6–8 dB.

\* See Table 5-4 on page 1:5-5.

Table 5-6. Receiver Tests for ASTRO Conventional Channels\*

Test Name	System Analyzer	Radio	Test Set	Comments
Bit Error rate (BER) Floor	<b>Mode:</b> Proj 25 Std <b>RF Control:</b> Gen <b>Output Level:</b> -47 dBm <b>Proj 25 Dev:</b> 2.83 kHz <b>Code:</b> 1011 Hz PAT	Radio Tuner Software (Bit Error Rate screen) is required	<b>PTT</b> to OFF (center)	BER < 0.01% (Use test setup shown in <a href="#">Figure 6-1 on page 1:6-1</a> )
Reference Sensitivity	As above; lower the output level until 5% BER is obtained	As above	As above	Output level < 0.35 $\mu$ V (-116 dBm) (Use test setup shown in <a href="#">Figure 6-1 on page 1:6-1</a> )
Audio Output Distortion	<b>Mode:</b> Proj 25 Std <b>RF Control:</b> Gen <b>Output Level:</b> -47 dBm <b>Proj 25 Dev:</b> 2.83 kHz <b>Code:</b> 1011 Hz PAT <b>Meter:</b> Ext. Distortion	Radio Tuner Software not used; <b>Radio:</b> Out of TEST MODE; Select a conventional ASTRO channel	<b>PTT</b> to OFF (center) Meter selector to <b>Audio PA Spkr/Load to Speaker</b>	Distortion < 3.0%

Table 5-6. Receiver Tests for ASTRO Conventional Channels\* (Continued)

Test Name	System Analyzer	Radio	Test Set	Comments
Residual Audio Noise Ratio	<b>Mode:</b> Proj 25 Std <b>RF Control:</b> Gen <b>Output Level:</b> -47 dBm <b>Proj 25 Dev:</b> 2.83 kHz <b>Code:</b> A) 1011 Hz PAT B) Silence PAT <b>Meter:</b> AC Volts	As above	As above	Residual Audio Noise Ratio -45 dB

\* These tests require a communications system analyzer with the ASTRO 25 test options.

## 5.5 Transmitter Performance Checks

The following tables outline the performance checks for the transmitter.

Table 5-7. Transmitter Performance Checks

Test Name	System Analyzer	Radio	Test Set	Comments
Reference Frequency	<b>RF Control:</b> Monitor <b>Meter:</b> RF Display <b>Display:</b> Bar Graphs <b>Freq:</b> Selected radio TX freq.	TEST MODE CSQ channel* or programmed conventional channel	<b>PTT</b> to continuous (during the performance check).	<b>VHF:</b> 2.0 ppm (272–348 Hz) <b>700/800 MHz:</b> 1.5 ppm (1.15–1.3 kHz) <b>UHF1:</b> 2 ppm (760–940 Hz) <b>UHF2:</b> 2 ppm (900–1040 Hz)
RF Power	As above	As above	As above	<b>VHF:</b> 1–6 Watts <b>700/800 MHz:</b> <b>764–806 MHz:</b> 2.5 Watts <b>806–870 MHz:</b> 3 Watts <b>UHF1:</b> 1–5 Watts <b>UHF2:</b> 1–5 Watts
Voice Modulation (external)	As above. Set fixed 1 kHz audio level to approximately 10 mV.	As above	As above	Deviation: (12.5 kHz) ≥ 2.1 kHz, but ≤ 2.5 kHz (25 kHz) ≥ 4.1 kHz, but ≤ 5.0 kHz
Voice Modulation (internal)	For Modulation Analyzer: FM measurements 15 kHz LP Filter	As above	Remove modulation input. <b>PTT</b> to OFF (center)	Press <b>PTT</b> button on radio. Say “four” loudly into the radio mic. Measure deviation: (12.5 kHz) ≥ 2.1 kHz but ≤ 2.5 kHz (25 kHz) ≥ 4.1 kHz but ≤ 5.0 kHz



Table 5-7. Transmitter Performance Checks (Continued)

Test Name	System Analyzer	Radio	Test Set	Comments
PL Modulation (radios with conventional, clear mode, coded squelch operation only)	For Modulation Analyzer: FM measurements 15 kHz LP Filter	Conventional coded squelch personality TPL channel (test mode*)	<b>PTT</b> to continuous (during the performance check)	Deviation: (12.5 kHz) $\geq 375$ Hz but $\leq 500$ Hz (25 kHz) $\geq 500$ Hz but $\leq 1000$ Hz
Secure Modulation (radios with conventional, secure mode, talkaround operation only)	As above	Programmed conventional channel (secure mode operation) Load key into radio.	As above	Deviation: $\geq 3.7$ kHz but $\leq 4.3$ kHz

\* See Table 5-4 on page 1:5-5.

Table 5-8. Transmitter Tests for ASTRO Conventional Channels\*

Test Name	System Analyzer	Radio	Test Set	Comments
RF Power	Aeroflex or equivalent Service Monitor	Select a Conventional Channel	<b>PTT</b> to continuous (during measurement).	<b>VHF:</b> 1–6 Watts <b>700/800 MHz:</b> <b>764–806 MHz:</b> 2.5 Watts <b>806–870 MHz:</b> 3 Watts <b>UHF1:</b> 1–5 Watts <b>UHF2:</b> 1–5 Watts
Frequency Error	As above	As above	As above	Error $\leq \pm 1.0$ kHz
Frequency Deviation	As above	Radio Tuner Software (Transmitter Test Pattern screen) is required) <b>High use:</b> Symbol Rate PAT <b>Low use:</b> Low Symbol Rate P	<b>PTT</b> to OFF (center)	$D_{HIGH}$ $\geq 2.543$ kHz but $\leq 3.110$ kHz $D_{LOW}$ $\geq 0.841$ kHz but $\leq 1.037$ kHz (Use test setup shown in <a href="#">Figure 6-1 on page 1:6-1</a> )

\* These tests require a communications system analyzer with the ASTRO 25 test options.

## Notes

# Chapter 6 Radio Alignment Procedures

This chapter describes both receiver and transmitter radio alignment procedures.

## 6.1 Test Setup

A personal computer (PC) and tuner software are required to align the radio. Refer to the applicable manual for installation and setup procedures for the software. To perform the alignment procedures, the radio must be connected to the PC and to a universal test set. The radio alignment test setup is shown in [Figure 6-1](#).

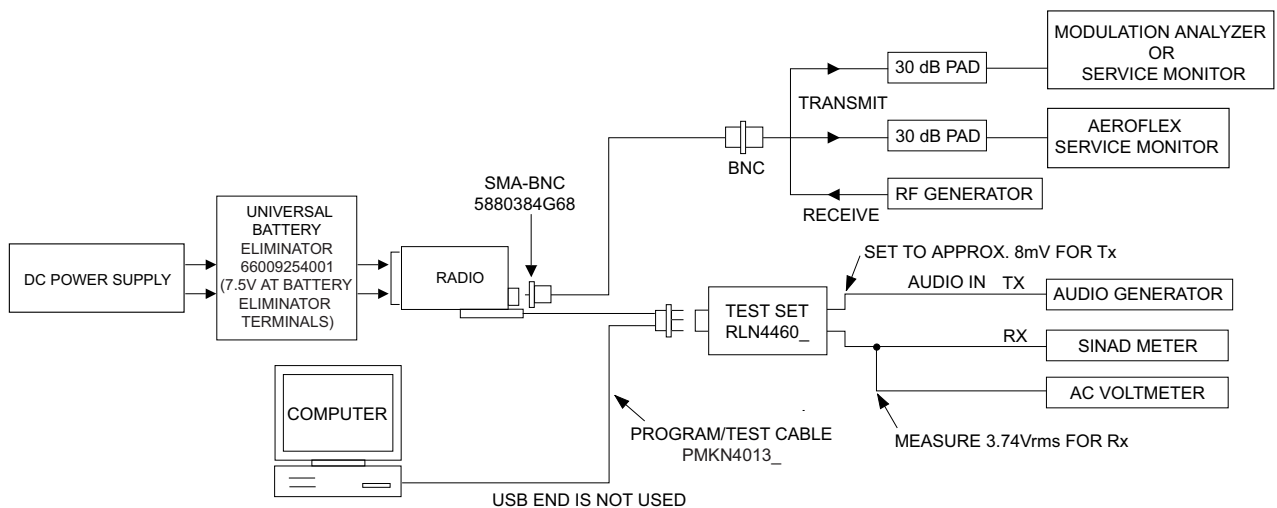



Figure 6-1. Radio Alignment Test Setup



Caution

These radio alignment procedures should only be attempted by qualified service personnel. Failure to perform alignment procedures properly may result in seriously degraded radio or system performance.

## 6.2 Tuner Main Menu

Select **Tuner** from the **START** menu by clicking **Start > Program Files > Motorola > ASTRO 25 Products > ASTRO 25 Tuner**. To read the radio, use the **File > Read Device** menu or click on . [Figure 6-2](#) illustrates how the alignment screens are organized. To access a screen, double-click on the desired screen name in the **Tuner** menu.

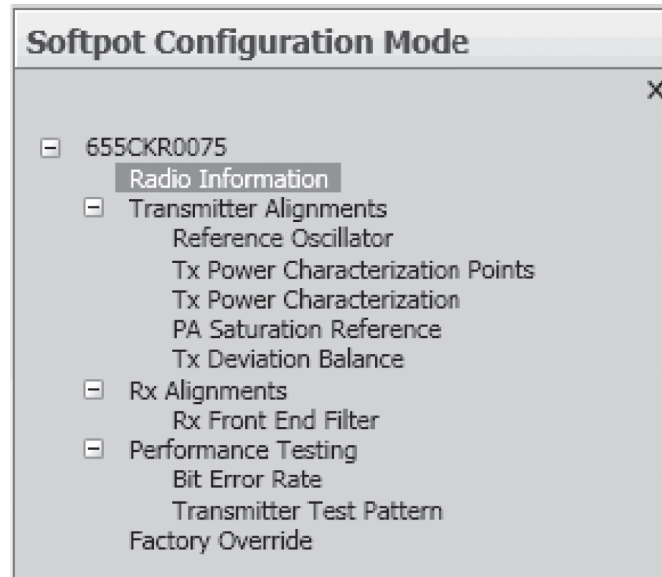

*Figure 6-2. Tuner Software Main Menu*

**IMPORTANT:** Tuning should follow the order of the Tuning tree view in descending order from top to bottom

## 6.3 Softpot

The alignment screens introduce the concept of the “softpot,” an analog **SOFTWARE**-controlled **POTentiometer** used for adjusting all transceiver alignment controls.

 Caution	<p>DO NOT switch radios in the middle of any alignment procedure. Always left-click the <b>Close</b> button on the screen to return to the Main Menu screen before disconnecting the radio. Improper exits from the alignment screens might leave the radio in an improperly configured state and result in seriously degraded radio or system performance.</p>
--	---

Each alignment screen provides the ability to increase or decrease the softpot value by using a slider, or by entering the new value from the keyboard directly into the box. The slider bar indicates the current softpot value; see [Figure 6-3](#).

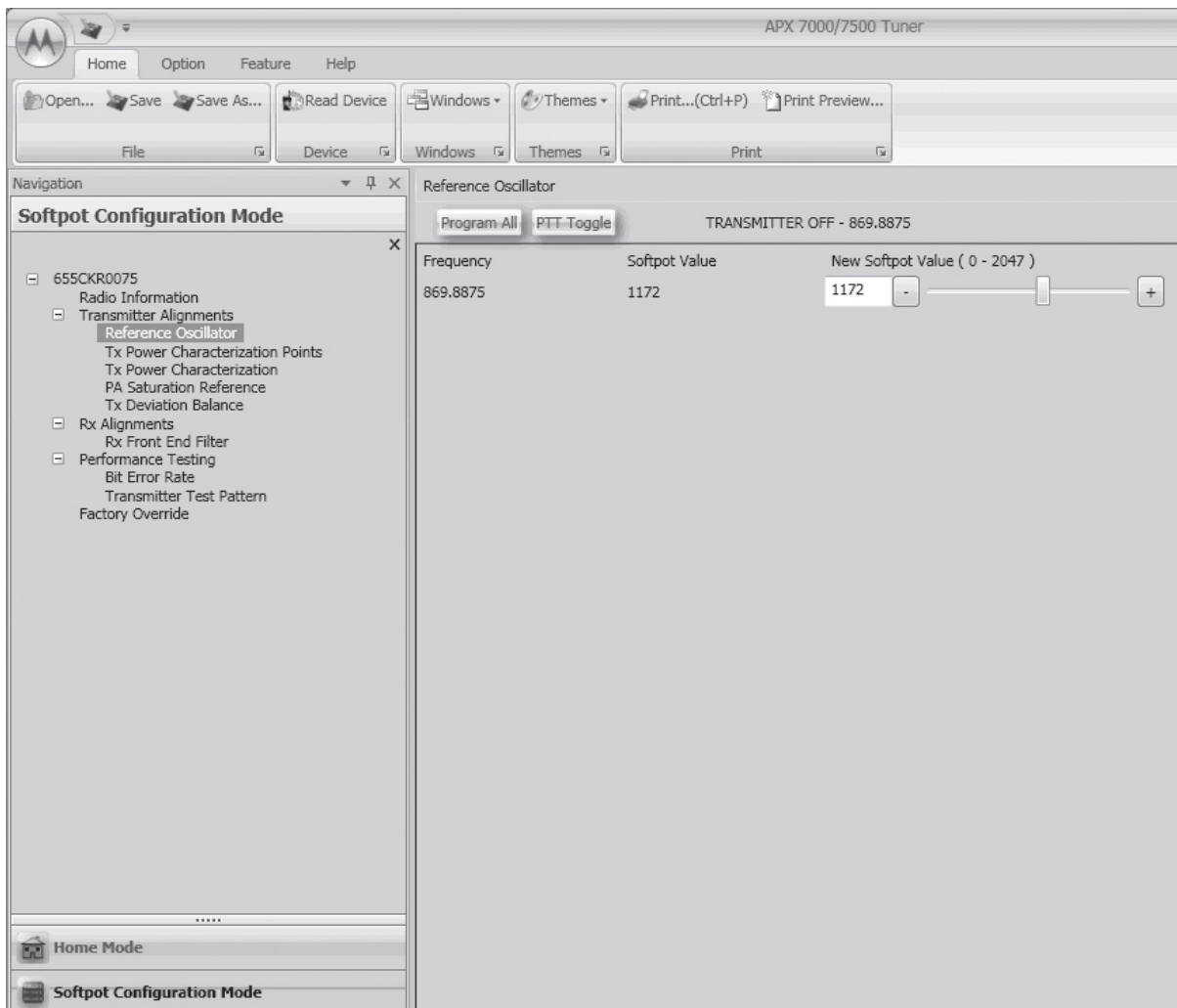

Figure 6-3. Typical Softpot Screen

Adjusting the softpot value sends information to the radio to increase (or decrease) the voltage in the corresponding circuit. For example, left-clicking the UP spin button in the New Softpot Value scroll box on the **Reference Oscillator** screen instructs the radio's microcomputer to increase the voltage across a varactor in the reference oscillator, which increases the frequency.

In ALL cases, the softpot value is just a relative number corresponding to a digital-to-analog (D/A) generated voltage in the radio.

Perform the following procedures in the sequence indicated.

**NOTE:** Some of the following screens may vary depending upon the radio under test and the version of tuner software you are using. Refer to the software's online help.



Caution

When keying the radio during a test, always transmit into a dummy load.

## 6.4 Radio Information

Figure 6-4 shows a typical Radio Information screen. This screen is informational only and cannot be directly changed.

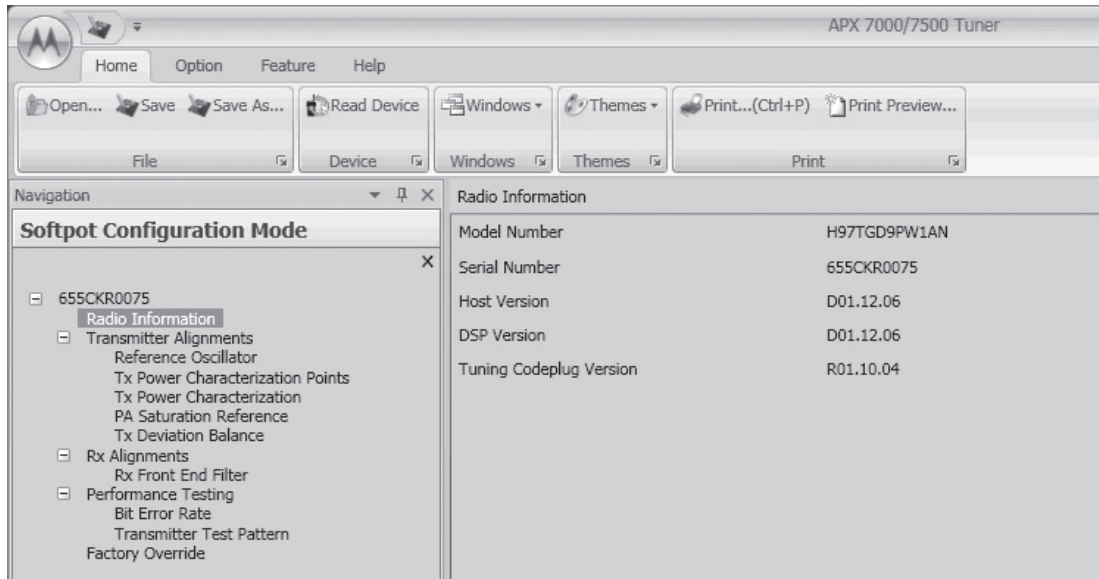

Figure 6-4. Radio Information Screen

## 6.5 Transmitter Alignments

### 6.5.1 Reference Oscillator Alignment

Adjustment of the reference oscillator is critical for proper radio operation. Improper adjustment will result not only in poor operation, but also in a misaligned radio that will interfere with other users operating on adjacent channels. For this reason, the reference oscillator should be checked every time the radio is serviced, or once a year, whichever comes first. The frequency counter used for this procedure must have a stability of 0.1 ppm (or better). Also, checking this parameter when the product is placed in service is especially important if the product has been in storage for a significant period of time (6 months or more) between being shipped from the factory and commissioned for service.

**NOTE:** Reference oscillator alignment is required after replacing (or servicing) the transceiver board.

This test can be done with either the R-2670 Communication Analyzer or the 8901\_ Modulation Analyzer.

- Initial setup using the R-2670 Communication Analyzer:
  - RF Control: MONITOR
  - B/W: WB
  - Freq: CPS frequency under test
  - Attenuation: 20dB
  - Mon RF in: RF I/O
  - Meter: RF Display
  - Mode: STD
  - Input Level: uV or W

- Display: Bar Graphs
- Squelch: Mid-range or adjust as necessary

- Initial setup using the 8901\_ Series Modulation Analyzer:
  - Press the green **Automatic Operation** button on the analyzer.
  - Press the **FREQ** key.
  - Type **7.1** followed by **SPCL** button to set the 8901B\_ modulation analyzer for maximum accuracy.

To align the reference oscillator:

1. Select the **Reference Oscillator** alignment screen. See [Figure 6-5](#) to [Figure 6-7](#).

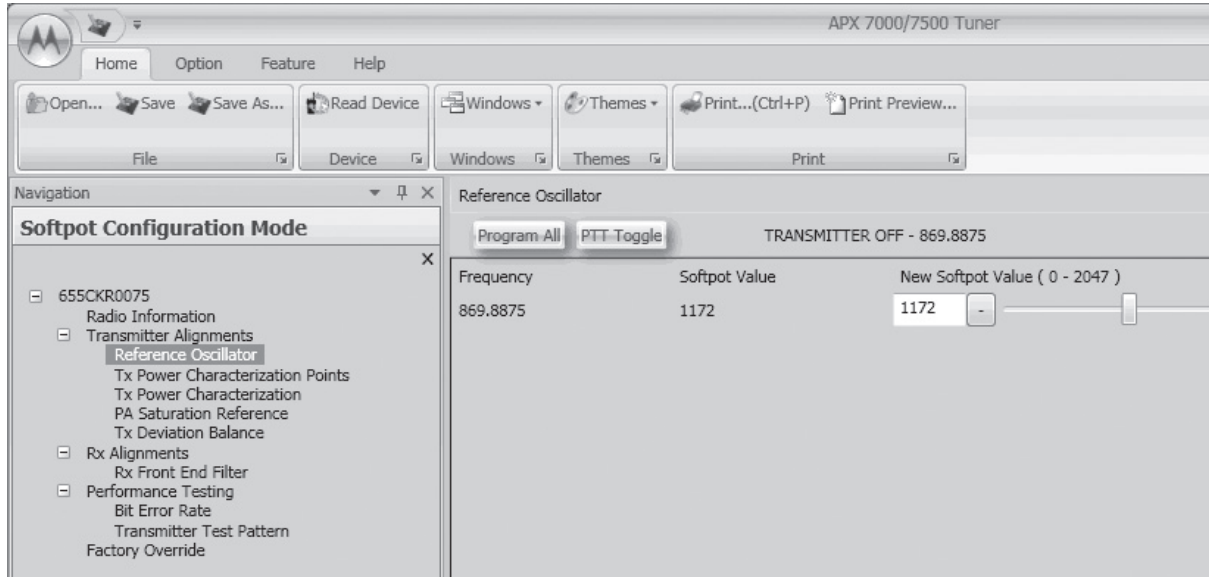

Figure 6-5. Reference Oscillator Alignment Screen (VHF and 700–800 MHz, UHF1 and 700–800 MHz, and UHF2 and 700–800 MHz)

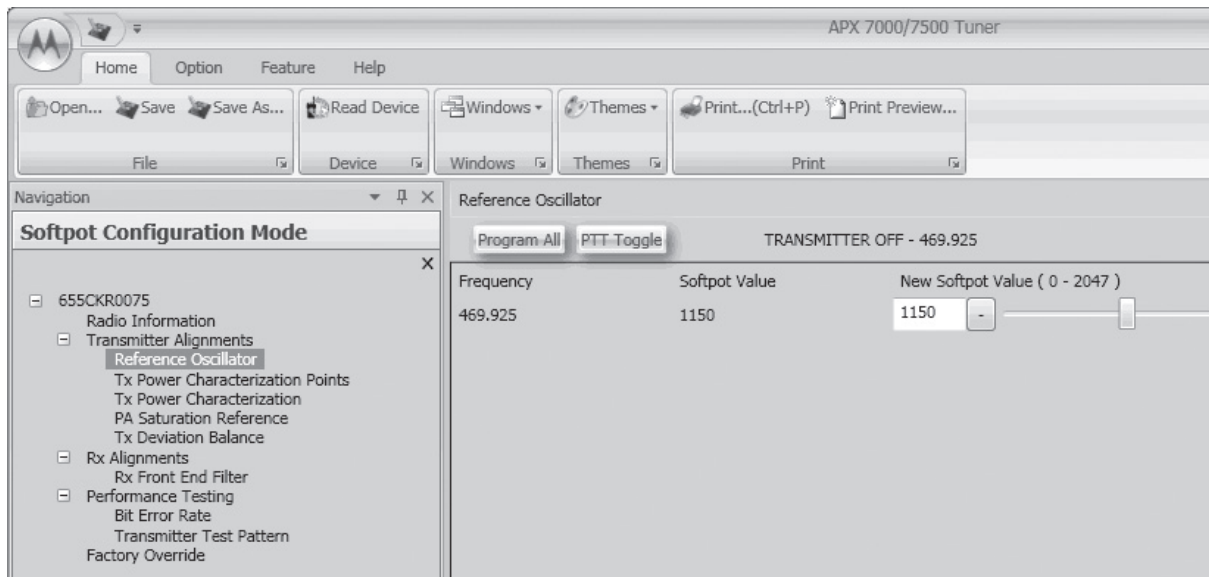

Figure 6-6. Reference Oscillator Alignment Screen (UHF1 and VHF, and UHF1 and UHF2)



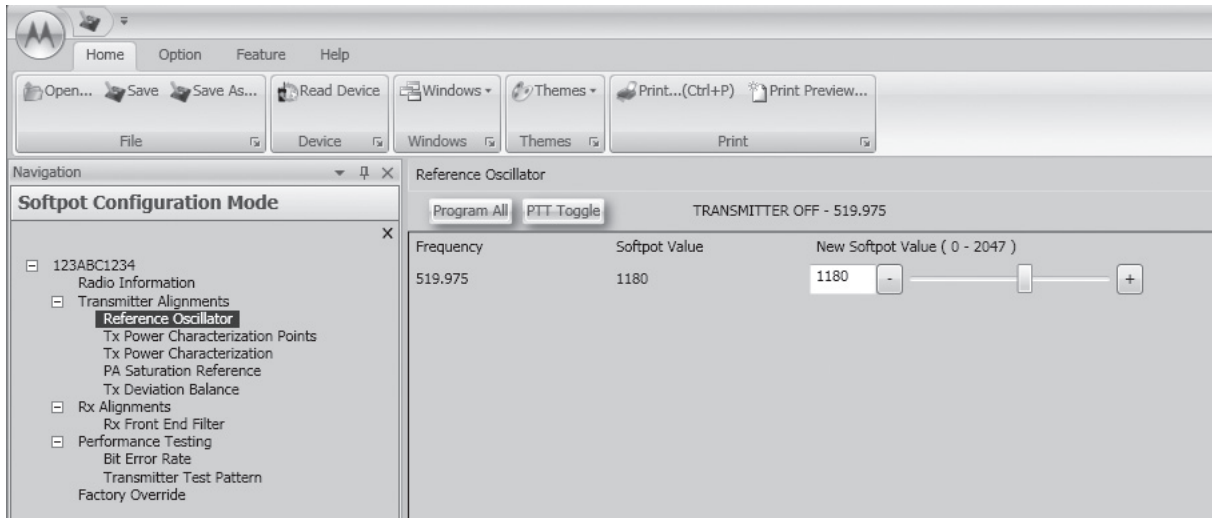

Figure 6-7. Reference Oscillator Alignment Screen (UHF2 and VHF)

- Make sure the Communication Analyzer is in **Manual** mode.
  - VHF and 700–800 MHz, UHF1 and 700–800 MHz ,and, UHF2 and 700–800 MHz
    - Set the base frequency to 869.8875 MHz
  - UHF1 and VHF
    - Set the base frequency to 469.925 MHz
  - UHF1 and UHF2
    - Set the base frequency to 469.925 MHz
  - UHF2 and VHF
    - Set the base frequency to 519.975 MHz
- Adjust the reference oscillator's softpot value with the slider until the measured value is as close as possible to the frequency shown on the screen. See [Table 6-1](#).
 

**NOTE:** Increases the slider decreases the frequency and vice versa.

Table 6-1. Reference Oscillator Alignment

Band	Target
VHF	±50 Hz
700 MHz/800 MHz	±50 Hz
UHF1	±50 Hz
UHF2	±50 Hz

- Left-click the **Program All** button on the screen to dekey the radio and save the tuned values.
- Left-click the **Close** button on the screen to return to the **Transmitter Alignments** menu.

### 6.5.2 Power Characterization Points

Tuning of the radio is done through **Power Characterization Points** tuning screen.

1. Select the **TX Power Characterization Points** alignment screen. See [Figure 6-8](#) to [Figure 6-13](#).
2. Set power supply voltage and current limit.
3. Adjust softpot value by manipulating the slider bar, incrementing the "New Softpot Value" text box, or directly entering the desired value into the "New Softpot Value" text box until the rated power is indicated on the service monitor. For rated power refer to the help text in the Tuner.
4. Repeat the steps 2 and 3 for all frequencies.
5. Left-click the **Program All** button on the screen to dekey the radio and save the tuned values.

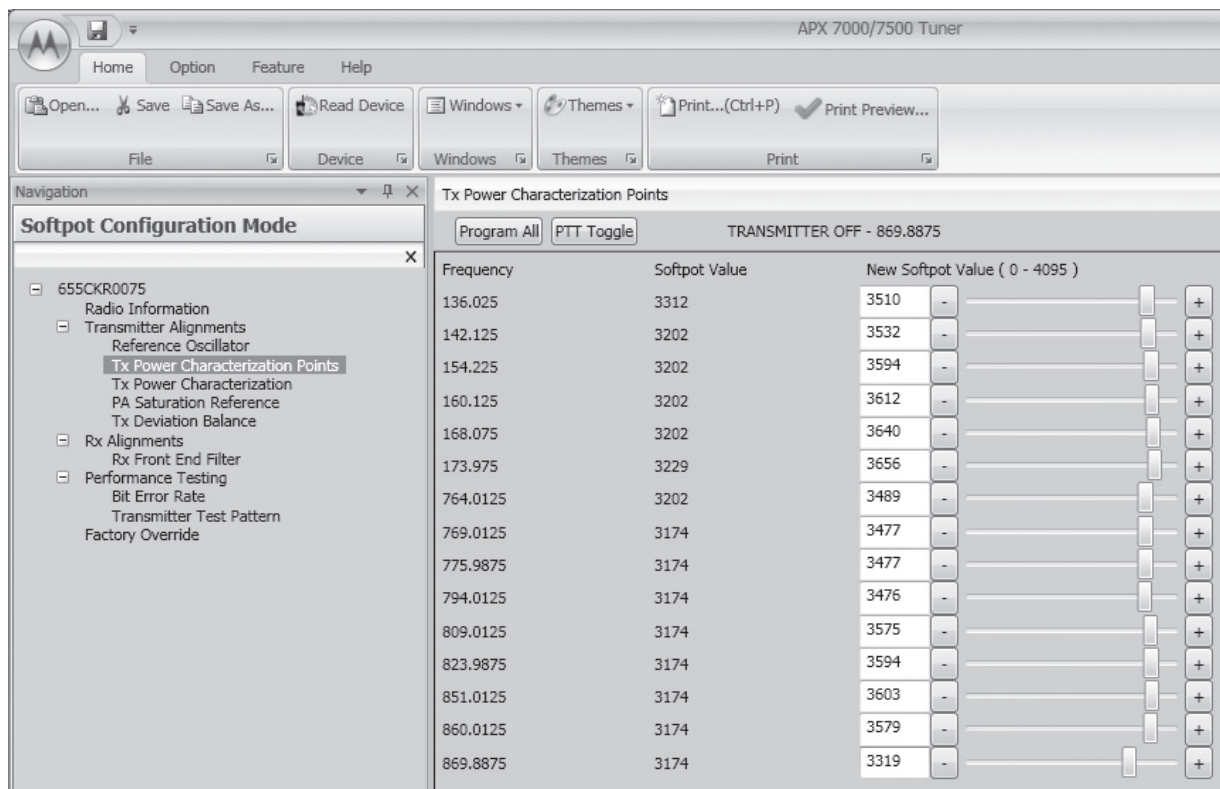

Figure 6-8. Transmit Power Characterization Points Alignment Screen (VHF and 700–800 MHz)

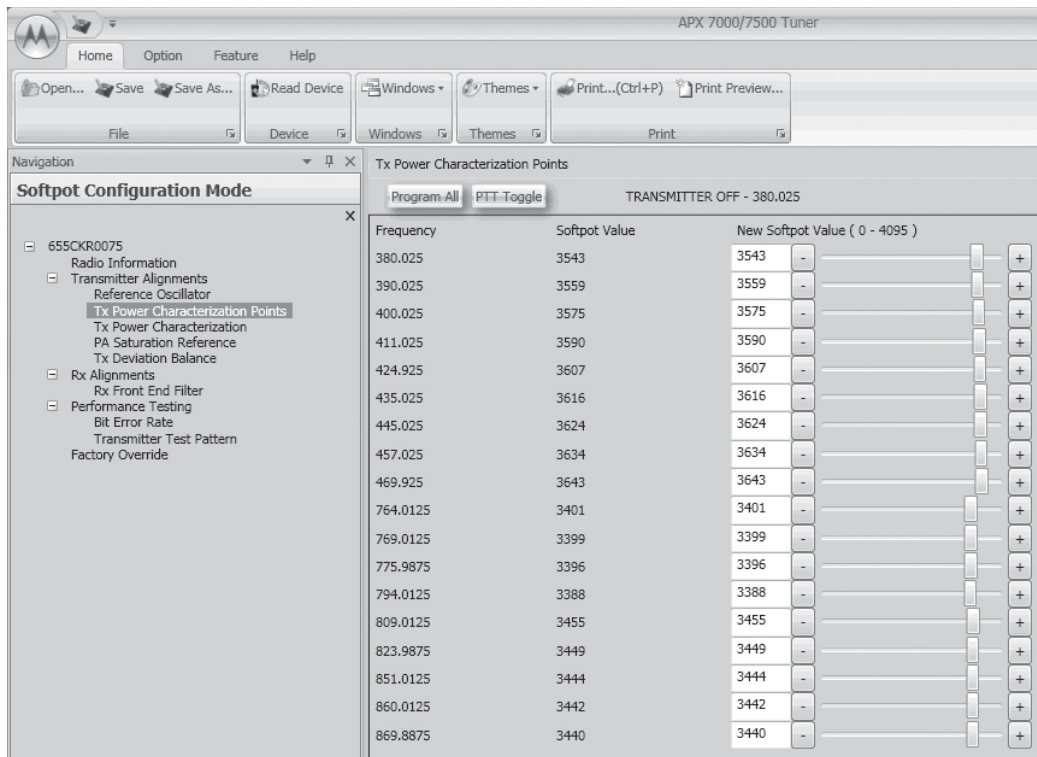

Figure 6-9. Transmit Power Characterization Points Alignment Screen (UHF1 and 700–800 MHz)

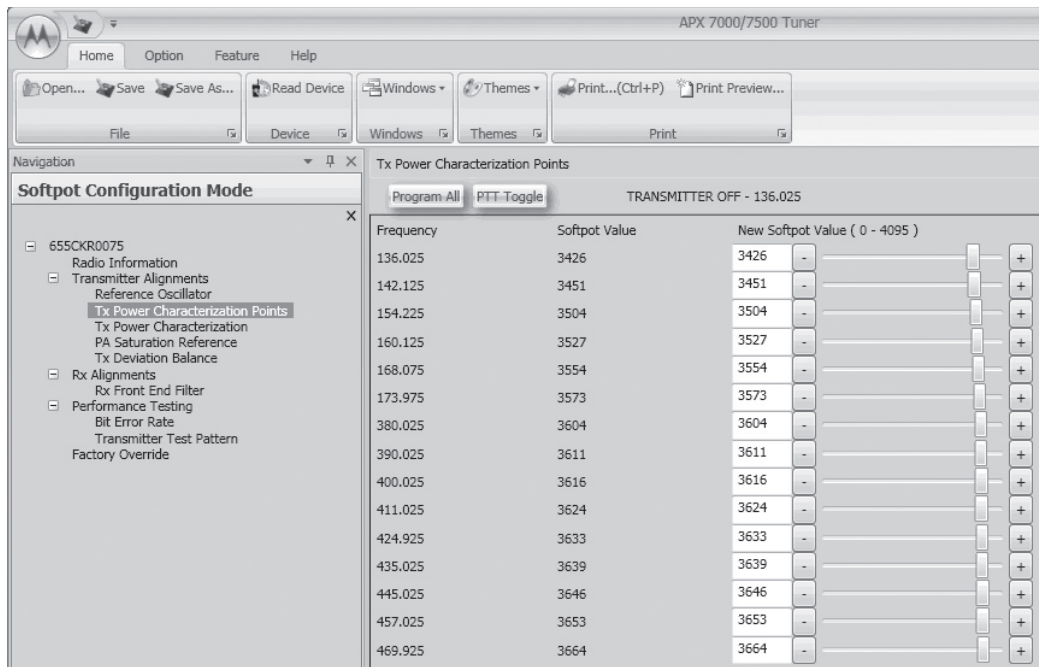

Figure 6-10. Transmit Power Characterization Points Alignment Screen (UHF1 and VHF)

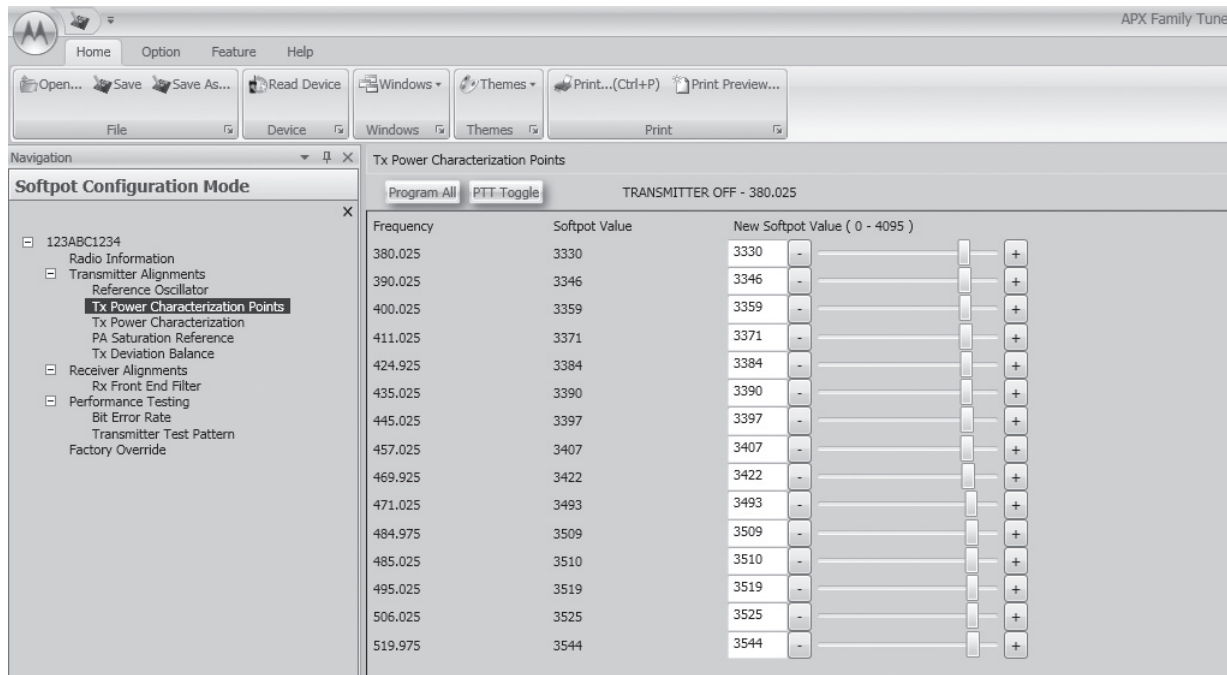

Figure 6-11. Transmit Power Characterization Points Alignment Screen (UHF1 and UHF2)

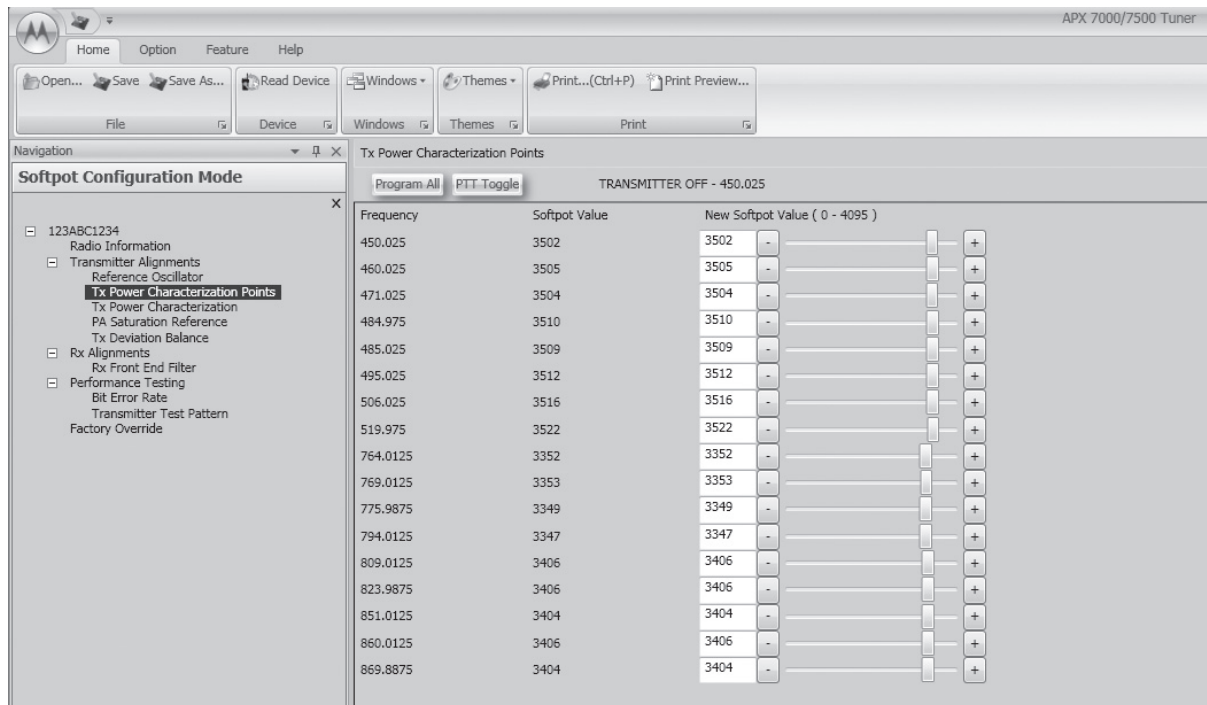

Figure 6-12. Transmit Power Characterization Points Alignment Screen (UHF2 and 700–800 MHz)

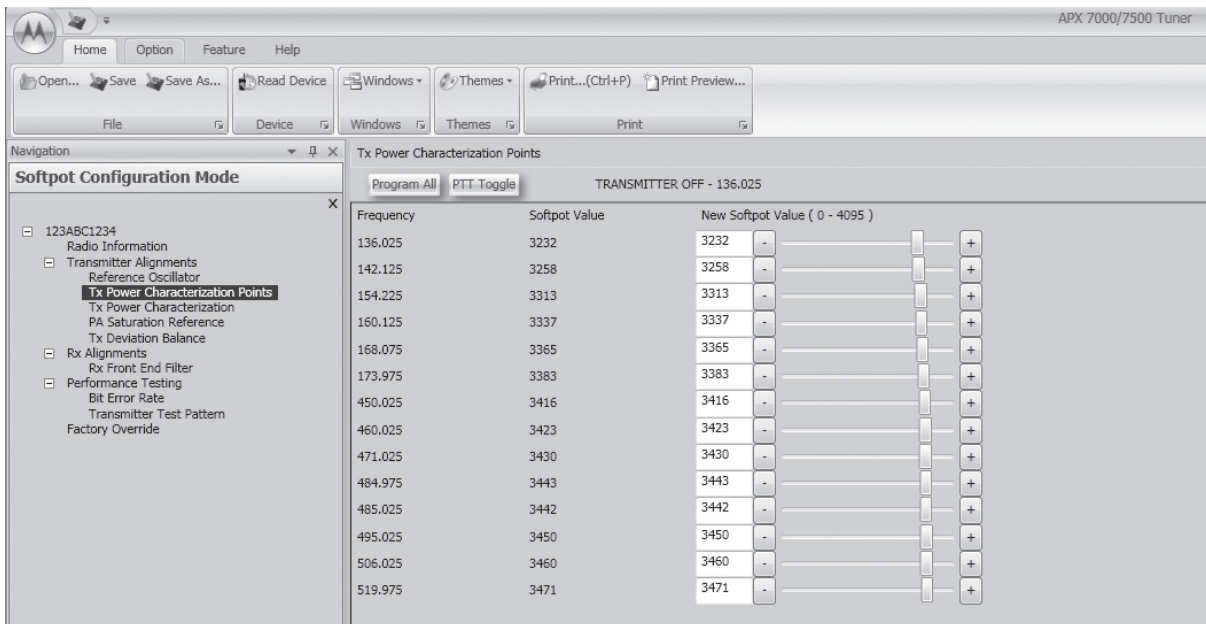

Figure 6-13. Transmit Power Characterization Points Alignment Screen (UHF2 and VHF)

### 6.5.3 Power Characterization Tuning

Tuning of the radio is done through **Power Characterization** tuning screen.

**IMPORTANT:** Power Characterization Tuning Points must be tuned before tuning Power Characterization Tuning.

**NOTE:** a. The longer the RF cable, the more the attenuation of the power reading.

b. Use a standard 50 ohm cable

c. Remember to set the Communication Analyzer to baseband power.

1. Select the **TX Power Characterization** alignment screen. The screen indicates the transmit power to be used. See [Figure 6-14](#) to [Figure 6-19](#).
2. Left-click the box under "Measure Power 1" for the desired frequency field. (The selected box is highlighted).
3. Click the **PTT Toggle** button on the screen to make the radio transmit. The screen indicates whether the radio is transmitting.
4. Measure the transmit power of the radio with a service monitor.
5. Input the transmit power in watts using two decimal places into the highlighted "Measure Power 1" box.
6. Left-click the box under "Measure Power 2" box for the same frequency field. (The selected box is highlighted).
7. Measure the transmit power of the radio with a service monitor.
8. Input the transmit power in watts using two decimal places into the highlighted "Measure Power 2" box.
9. Repeat steps 2 to 8 for all frequencies.
10. Left-click the **Program All** button on the screen to dekey the radio and save the tuned values.

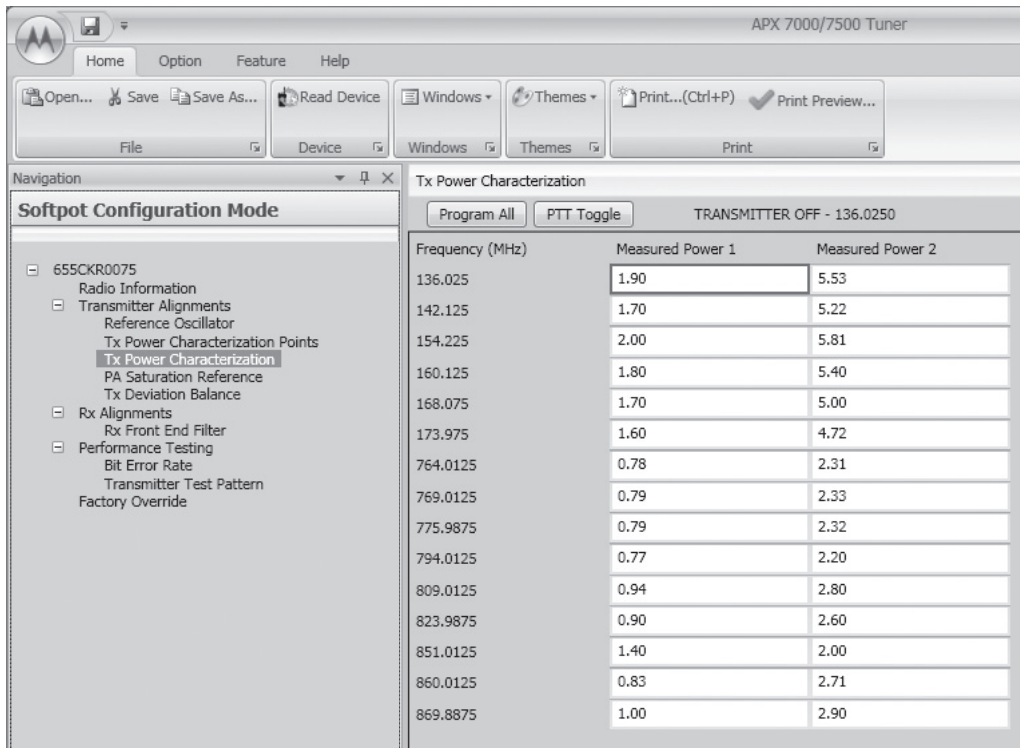

Figure 6-14. Transmit Power Characterization Alignment Screen (VHF and 700–800 MHz)

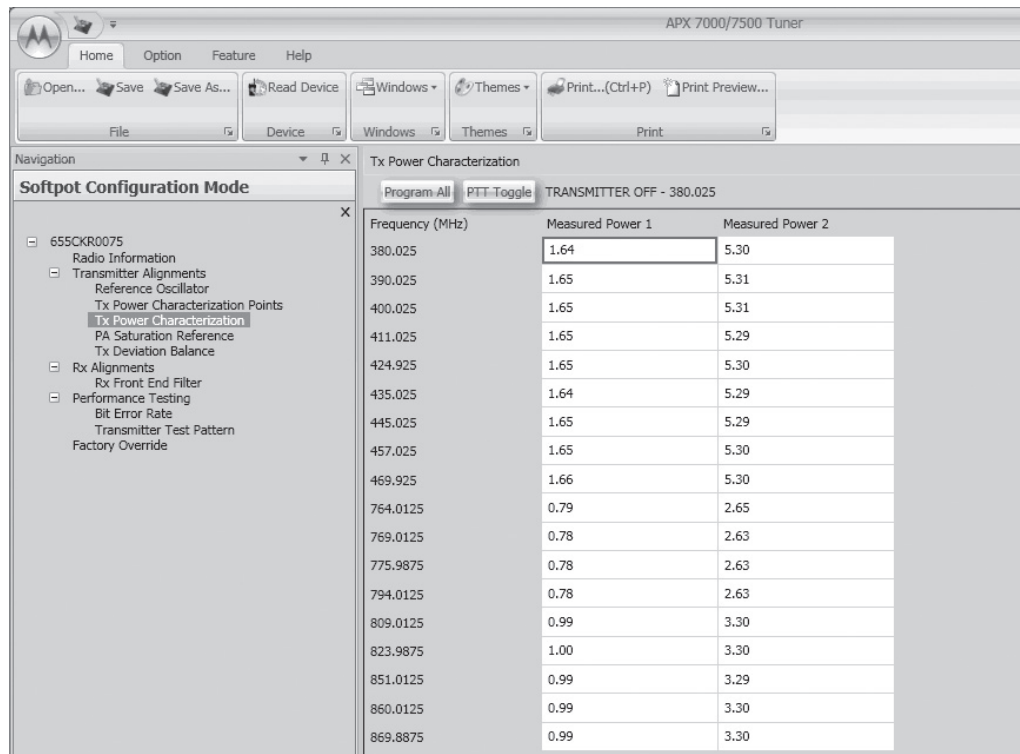

Figure 6-15. Transmit Power Characterization Alignment Screen (UHF1 and 700–800 MHz)

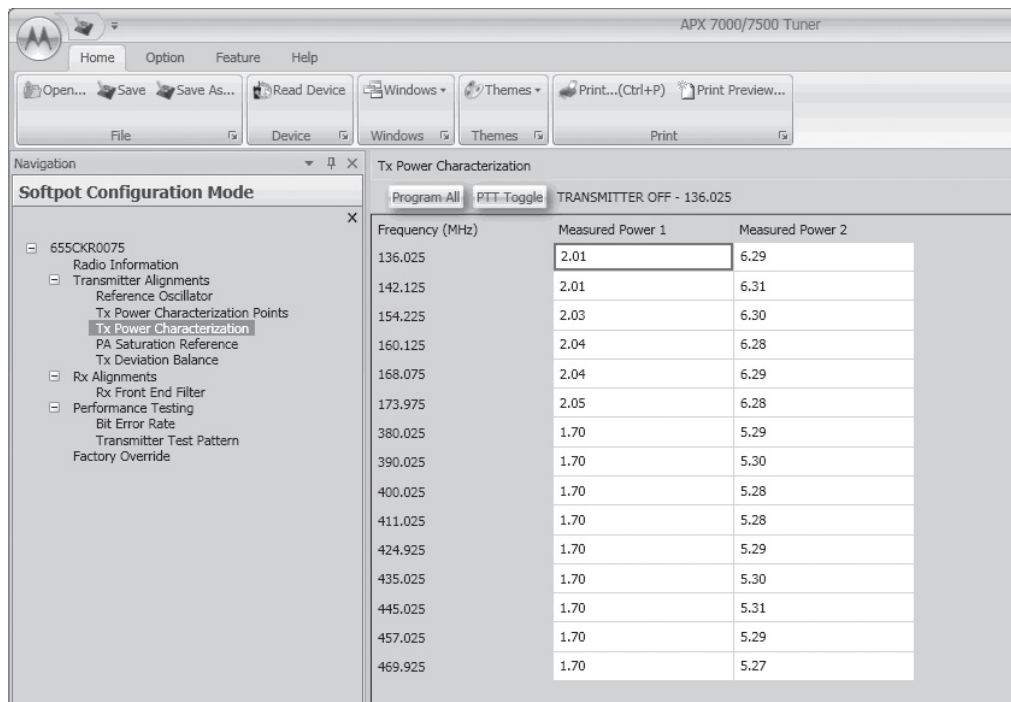

Figure 6-16. Transmit Power Characterization Alignment Screen (UHF1 and VHF)

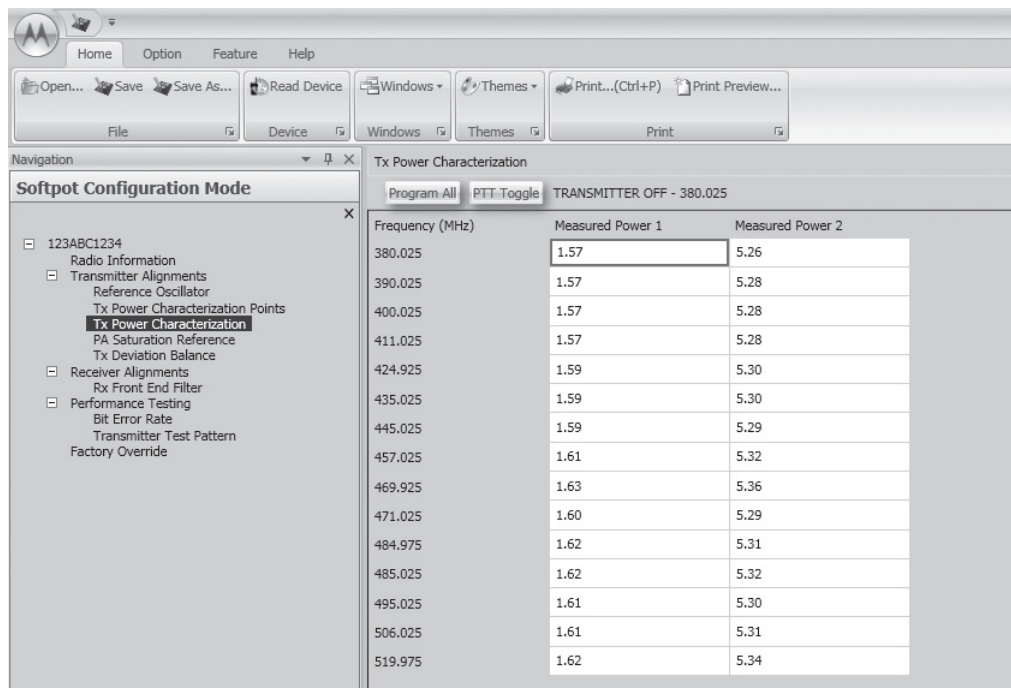

Figure 6-17. Transmit Power Characterization Alignment Screen (UHF1 and UHF2)



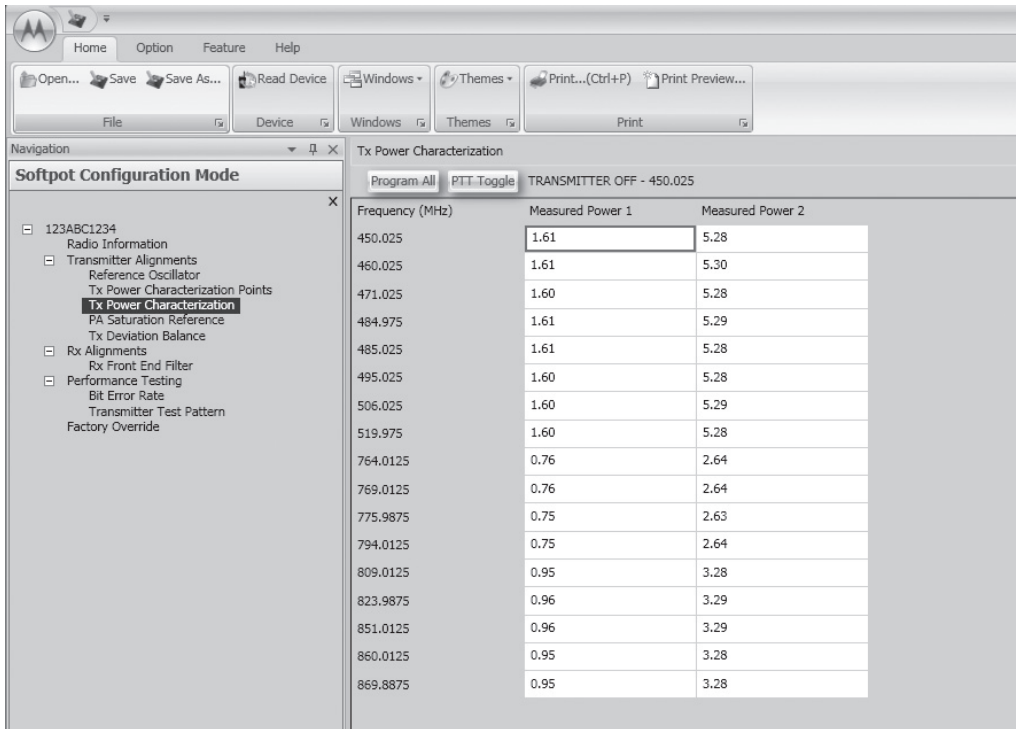

Figure 6-18. Transmit Power Characterization Alignment Screen (UHF2 and 700–800 MHz)

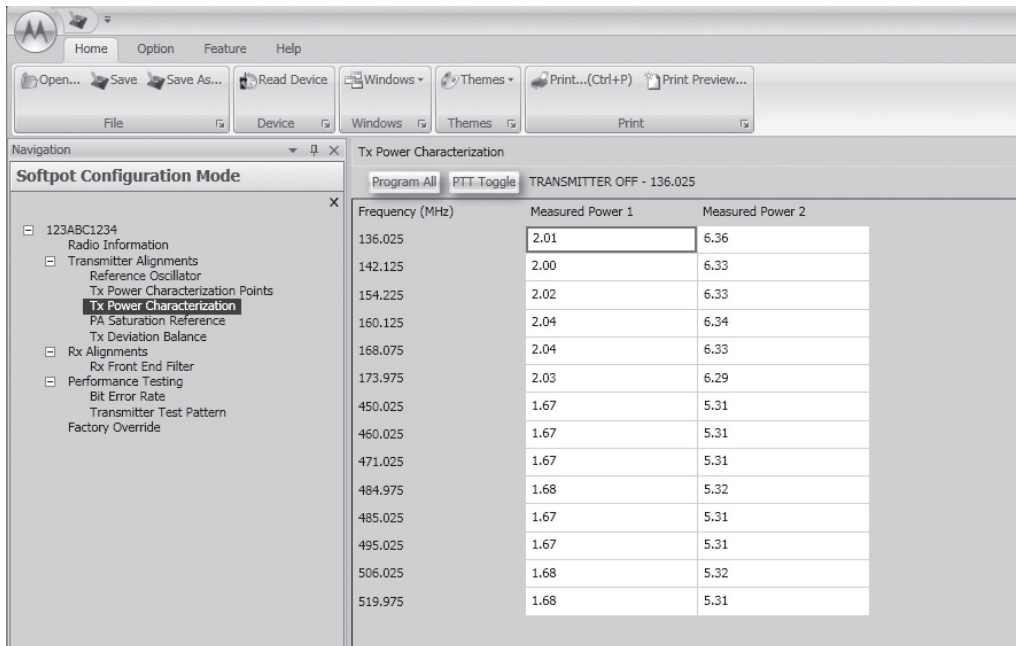

Figure 6-19. Transmit Power Characterization Alignment Screen (UHF2 and VHF)



## 6.5.4 PA Saturation Reference Tuning

Tuning is done through **PA Saturation Referencing** screen.

1. Select the **PA Saturation Reference** alignment screen. The screen indicates the transmit frequencies to be used. See [Figure 6-20](#) to [Figure 6-25](#).
2. In Manual Mode, set the service monitor to the desired frequency (as shown in the frequency list in the PA Saturation Reference alignment screen).
3. Adjust the PA Saturation Reference softpot value with the slider until the radio transmits as close as possible to the rated power. For rated power refer to the help text in the Tuner.
4. Left-click the slider of the frequency selected (should be the same frequency as step 2).
5. Left-click the **PTT Toggle** button on the screen to make the radio transmit. The screen indicates whether the radio is transmitting.
6. Repeat the steps 2 to 5 for all frequencies.
7. Left-click the **Program All** button on the screen to dekey the radio and save the tuned values.

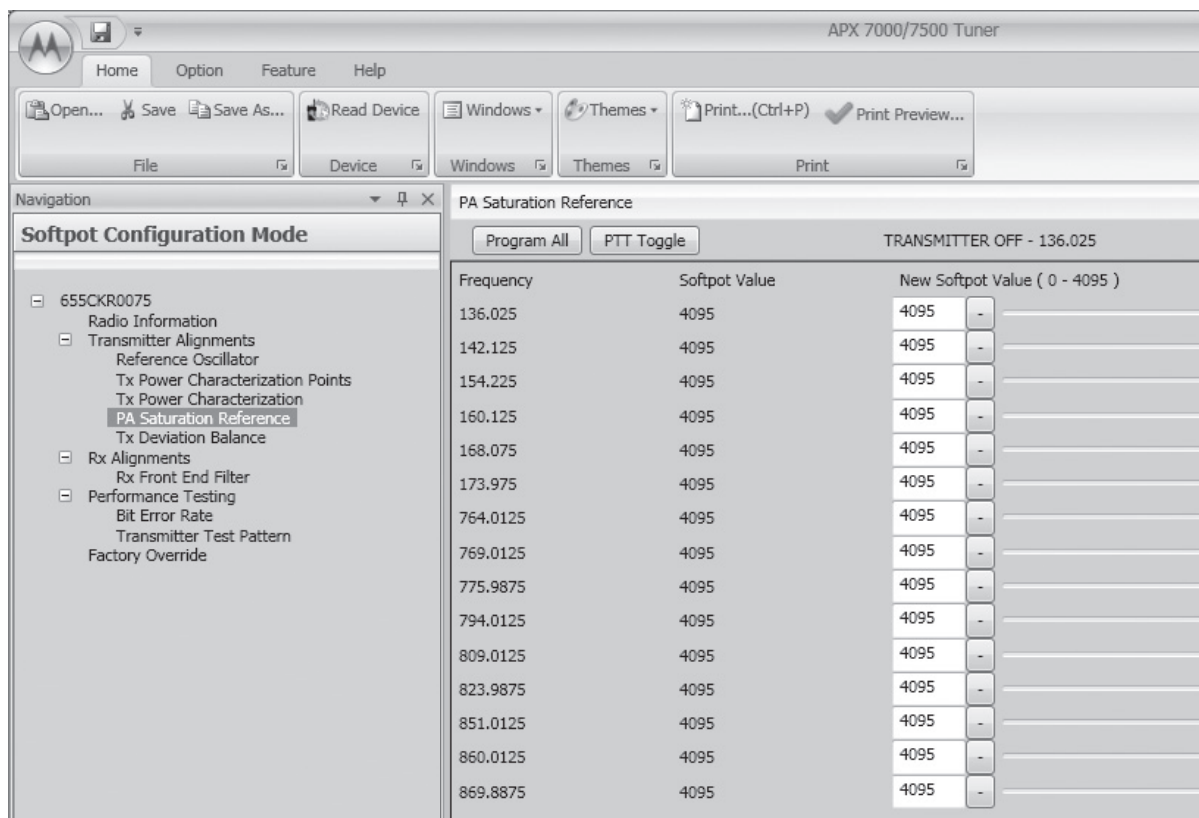

Figure 6-20. PA Saturation Referencing Alignment Screen (VHF and 700–800 MHz)

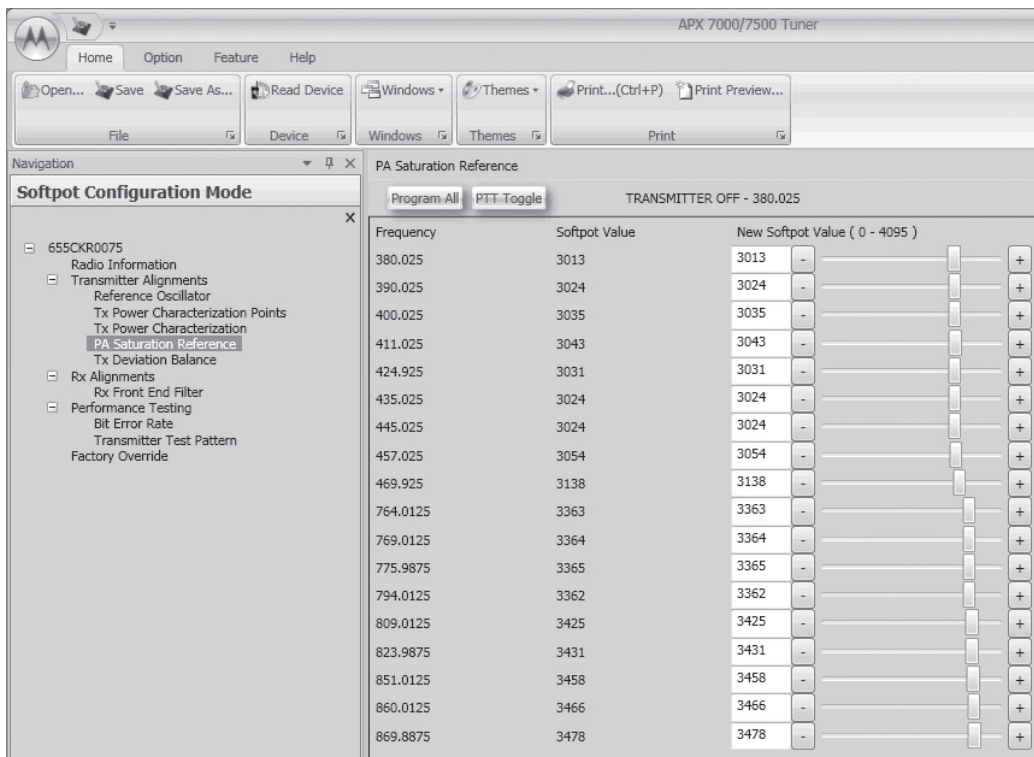

Figure 6-21. PA Saturation Referencing Alignment Screen (UHF1 and 700–800 MHz)

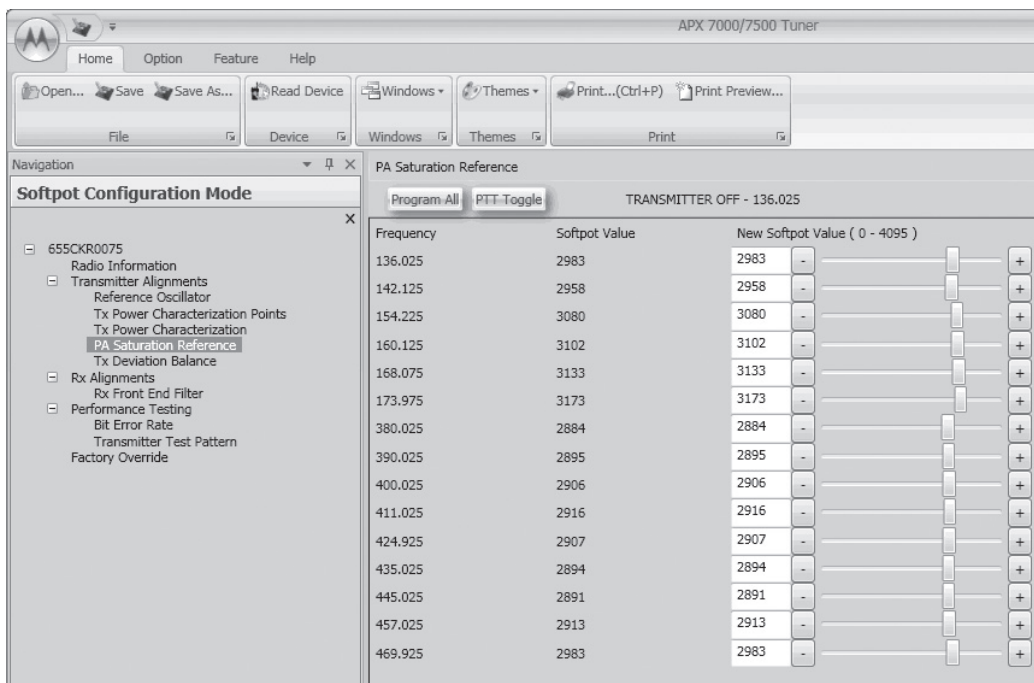

Figure 6-22. PA Saturation Referencing Alignment Screen (UHF1 and VHF)

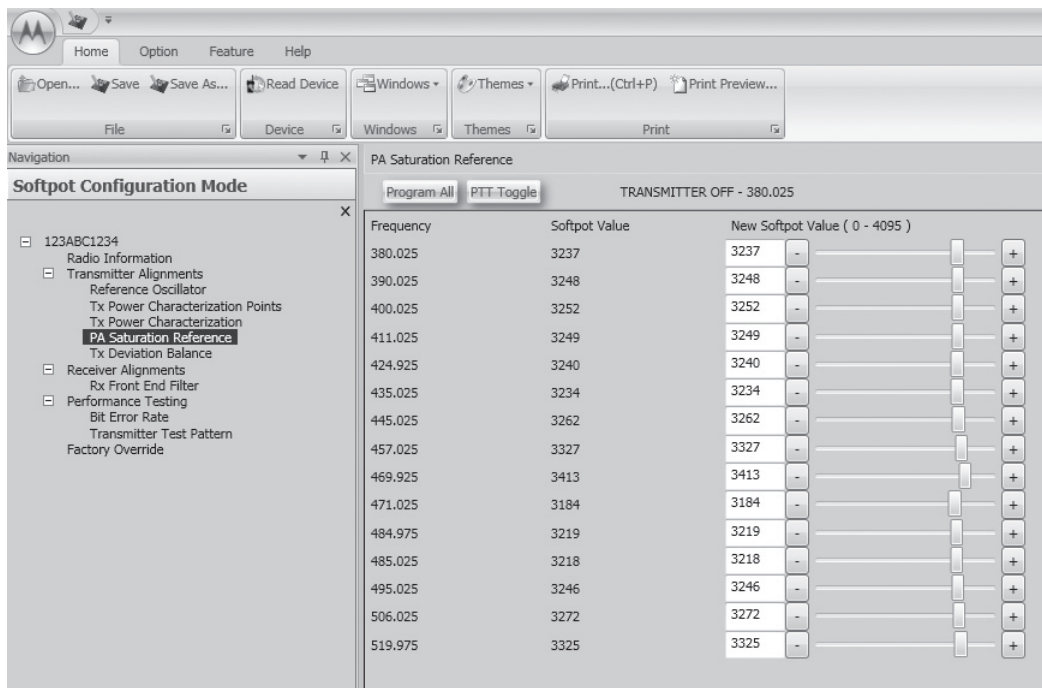

Figure 6-23. PA Saturation Referencing Alignment Screen (UHF1 and UHF2)

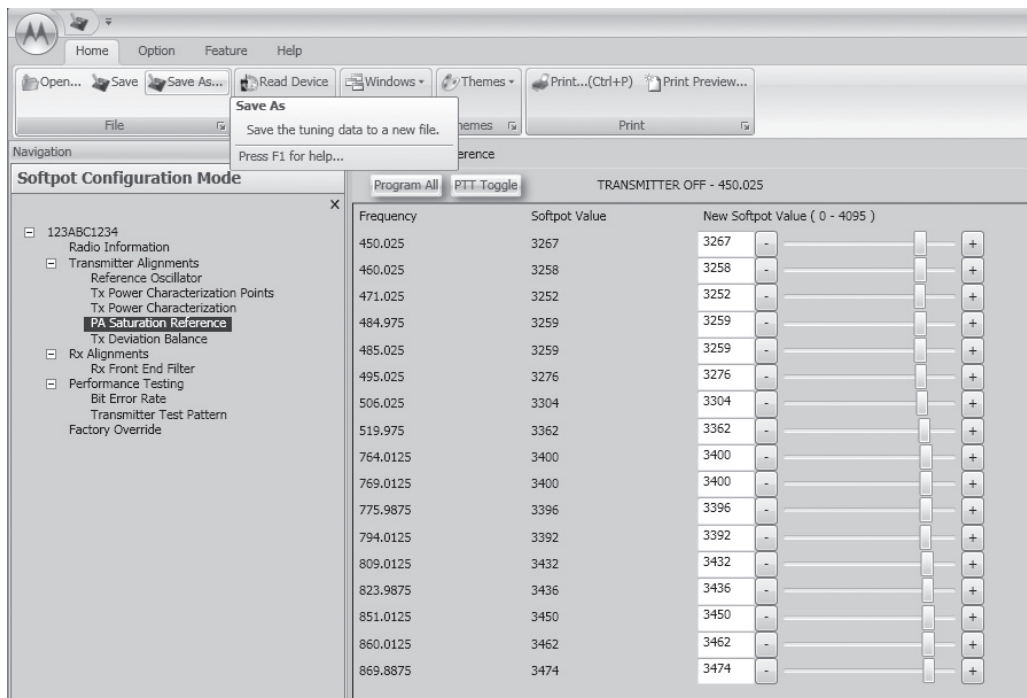

Figure 6-24. PA Saturation Referencing Alignment Screen (UHF2 and 700–800 MHz)

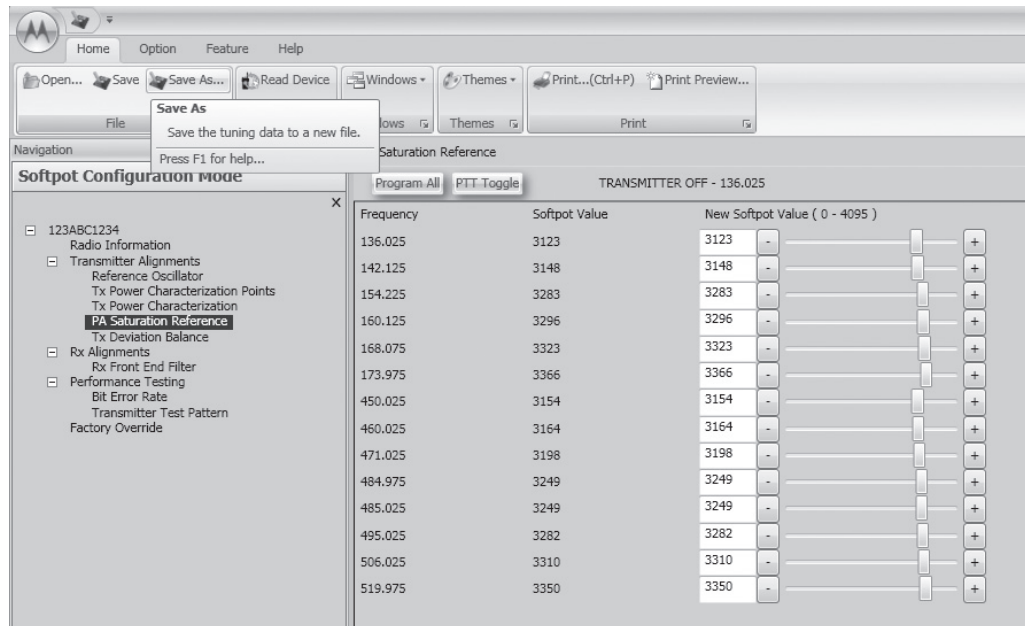

Figure 6-25. PA Saturation Referencing Alignment Screen (UHF2 and VHF)

### 6.5.5 Transmit Deviation Balance Alignment

This alignment procedure balances the modulation contributions of the low- and high-frequency portions of a baseband signal. Proper alignment is critical to the operation of signalling schemes that have very low frequency components (for example, DPL) and could result in distorted waveforms if improperly adjusted.

This procedure needs to be performed at multiple frequencies to allow for proper alignment across the entire RF band. The RF band is divided into frequency zones with a calibration point (value) in each zone.

**NOTE:** This alignment is required after replacing (or servicing) the VOCON board or the transceiver board.

Proper alignment requires a modulation analyzer or meter with a frequency response to less than 10 Hz modulating frequency. The modulation analyzer settings during this test should be set for average deviation, a 15 kHz low-pass filter, no de-emphasis, and no high-pass filter, if these settings are supported.

This alignment can be done with either the R-2670 Communication Analyzer or the 8901\_ Series Modulation Analyzer. The method of choice is the R-2670 analyzer.

- Initial setup using the R-2670 Communication Analyzer:
  - Connect a BNC cable between the "DEMOD OUT" port and the "VERT/SINAD DIST/DMM COUNTER IN" port on the R-2670.
  - Press the **SPF** key on the R-2670 to display the "SPECIAL FUNCTIONS MENU." Move the cursor to "High Pass," and select 5 Hz on the soft key menu. Select 20 kHz for the "Low Pass" setting.
  - In the "RF Control" section of the R-2670, move the cursor to the "B/W" setting and select "WIDE +/- 100 kHz" on the soft key menu.

- Place the R-2670 cursor in the “Display” zone. Select “AC VOLTS” on the soft key menu. Move the cursor to the “Range” setting and select “AUTO.”
2. Initial setup using the 8901\_ Series Modulation Analyzer:
    - Press the **FM MEASUREMENT** button. (The “Error 03-input level too low” indication is normal until an input signal is applied.)
    - Simultaneously press the **Peak –** and **Peak +** buttons. Both LEDs on the buttons should light.
    - Press the 15 kHz LP filter key.
  3. Select the **TX Deviation Balance** alignment screen. The screen indicates the transmit frequencies to be used. See [Figure 6-26](#) to [Figure 6-31](#).
  4. In the "RF Control" section of the R2670, set the service monitor to the desired frequency (as shown in the frequency list in the TX Deviation Balance alignment screen).
  5. Left-click the **PTT Tone: Low** button.
  6. Left-click the slider of the frequency selected (should be the same frequency as step 4).
  7. Left-click the **PTT Toggle** button on the screen to make the radio transmit. The screen indicates whether the radio is transmitting.
  8. Measure and Record the Low Tone Tx Deviation value from the 8901\_ Series Analyzer or the AC voltage value from the R2670.

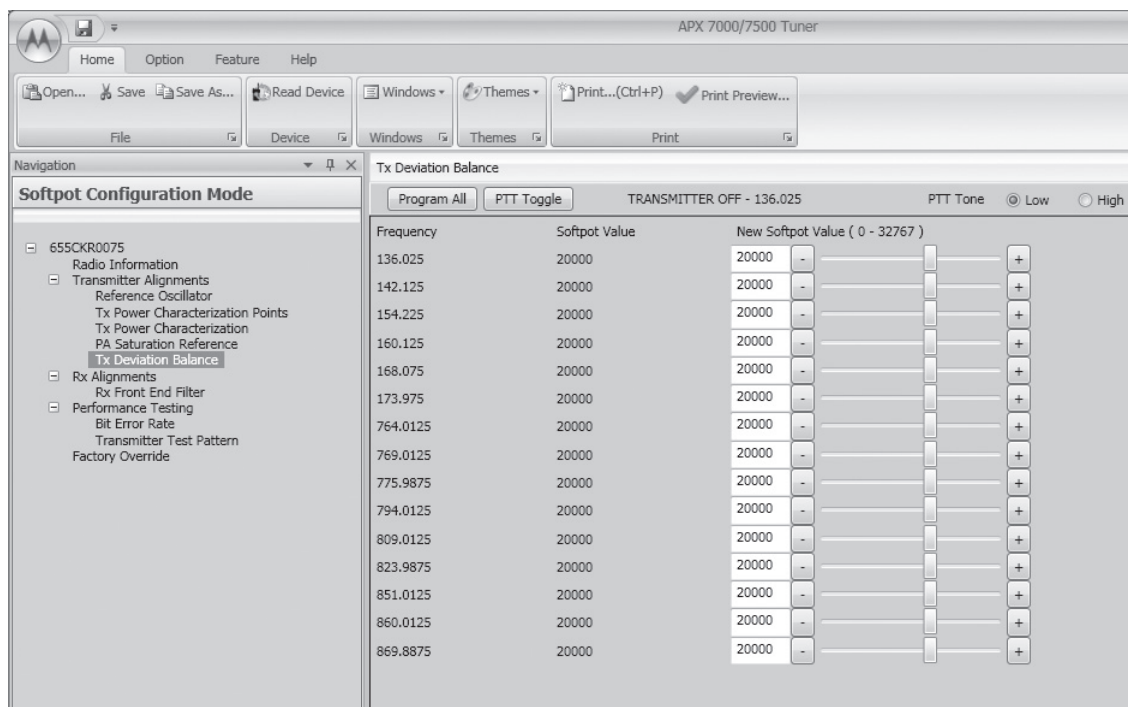

Figure 6-26. Transmit Deviation Balance Alignment Screen (VHF and 700–800 MHz)

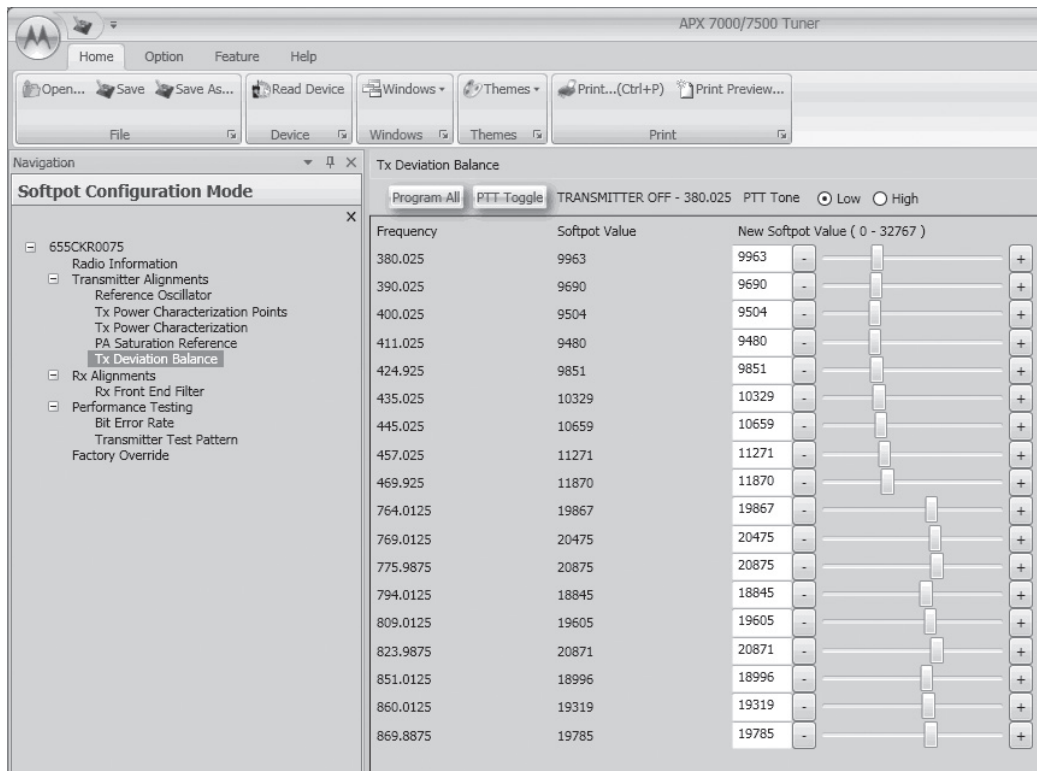

Figure 6-27. Transmit Deviation Balance Alignment Screen (UHF1 and 700–800 MHz)

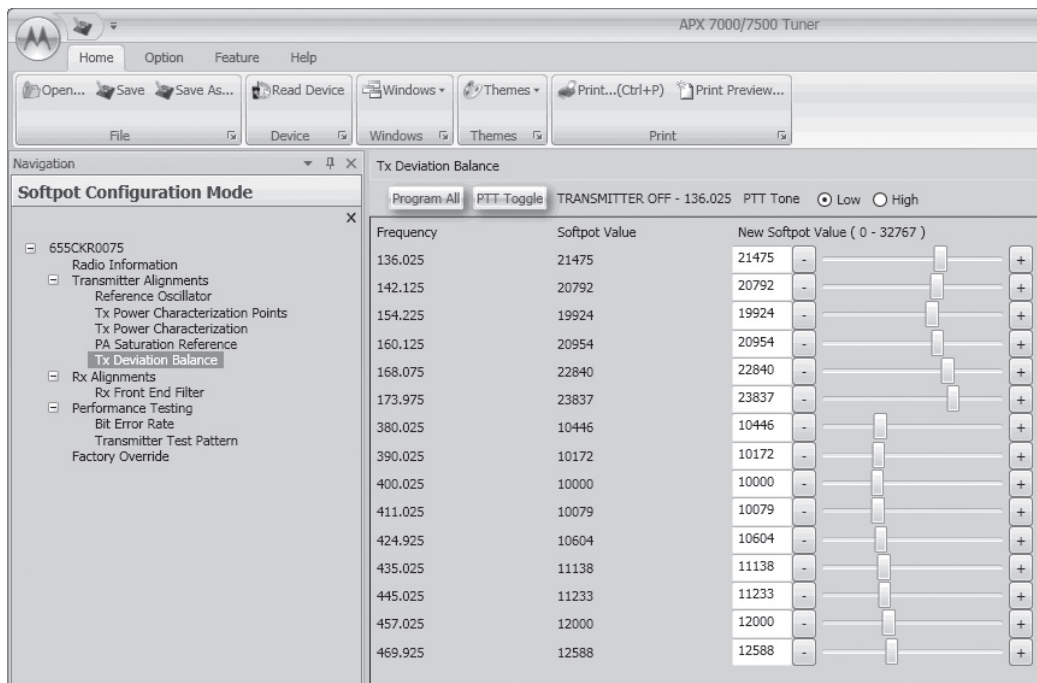

Figure 6-28. Transmit Deviation Balance Alignment Screen (UHF1 and VHF)



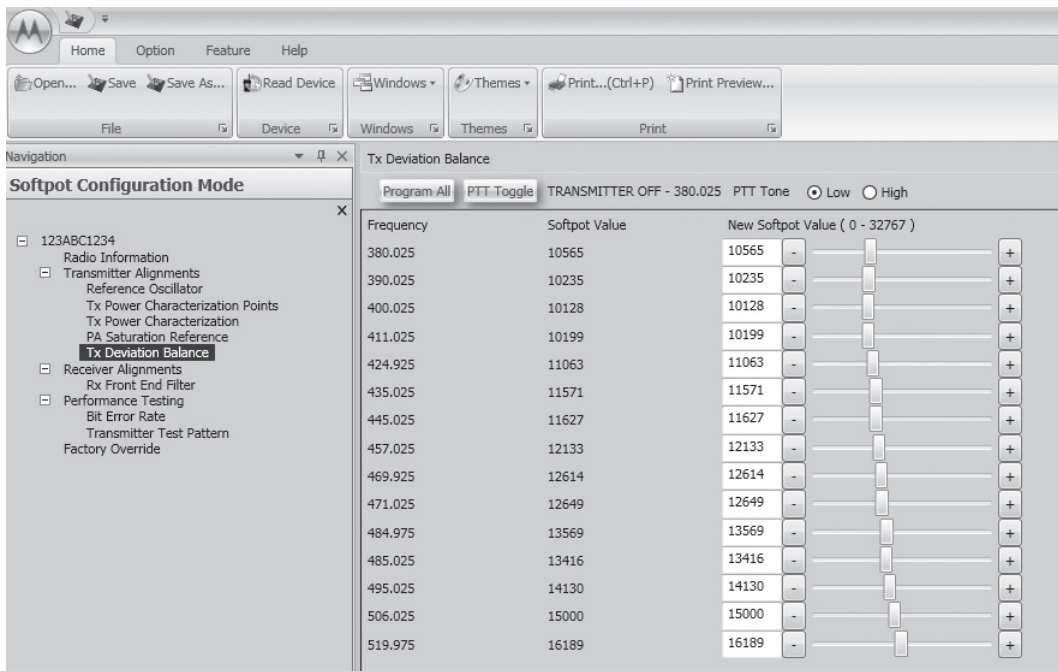

Figure 6-29. Transmit Deviation Balance Alignment Screen (UHF1 and UHF2)

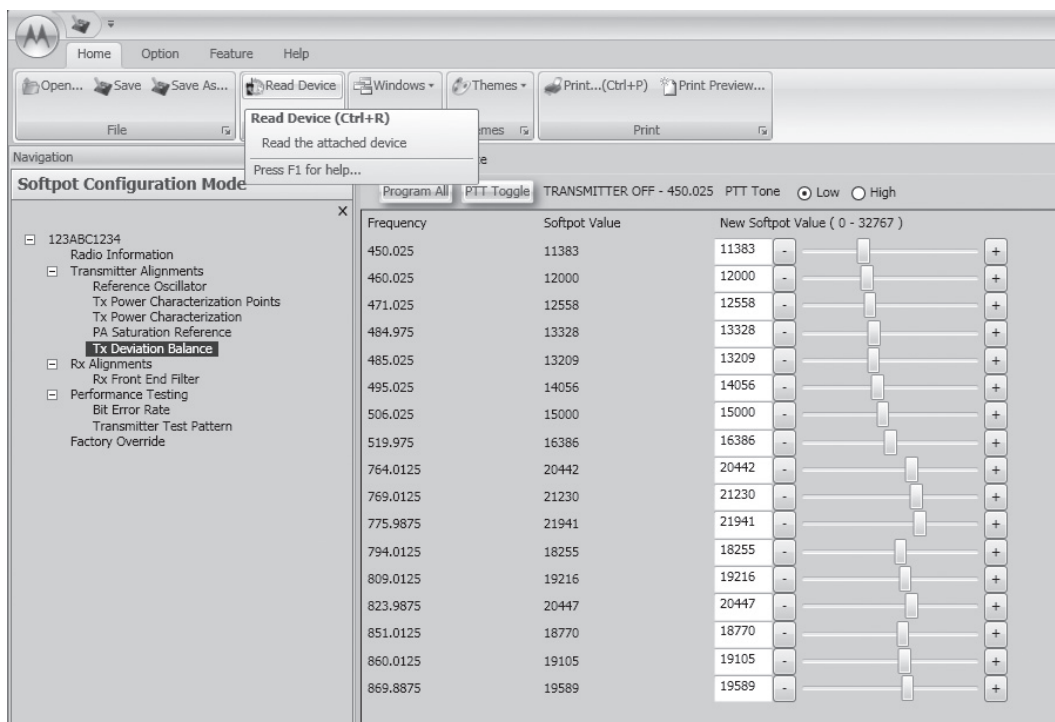

Figure 6-30. Transmit Deviation Balance Alignment Screen (UHF2 and 700–800 MHz)

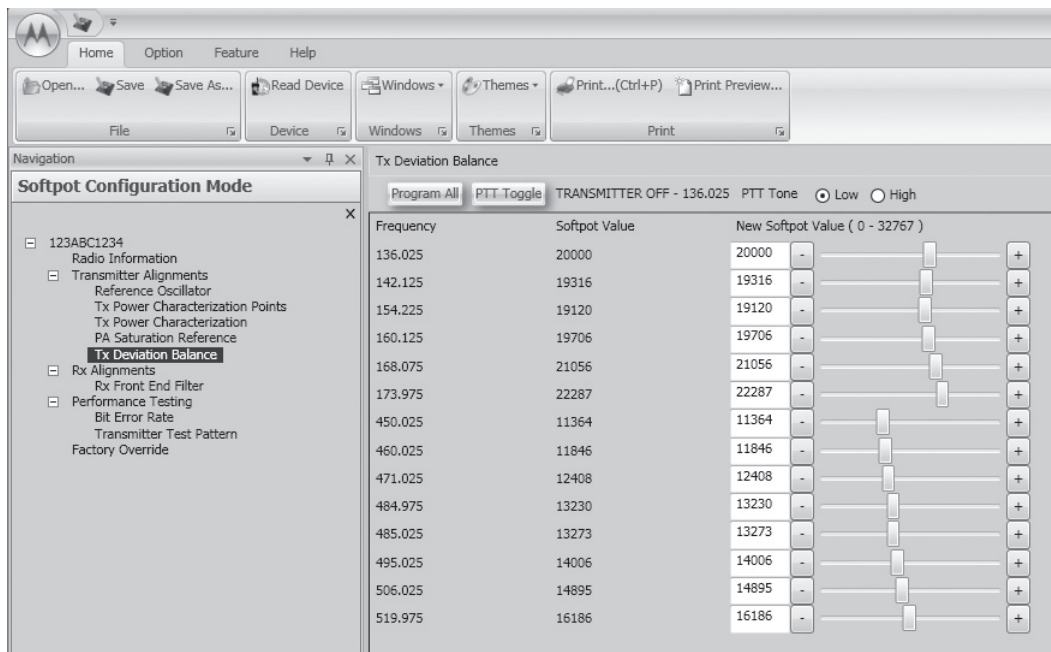
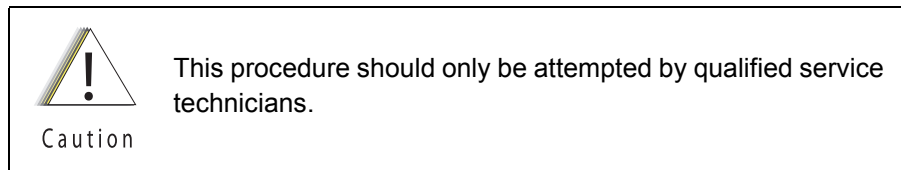

Figure 6-31. Transmit Deviation Balance Alignment Screen (UHF2 and VHF)

9. Left-click the **PTT Tone: High** button.
10. Adjust the softpot value until the measured deviation/voltage, when using the high tone, is within +/- 1.5% of the value observed when using the Low Tone.
11. Left-click the **PTT Toggle** to de-key the radio.
12. Repeat the steps 4 to 10 for all frequencies.
13. Left-click the **Program All** button on the screen to dekey the radio and save the tuned values.



## 6.6 Front End Filter Alignment



The alignment procedure adjusts the front end receiver bandpass filters for the best receiver sensitivity and selectivity. This procedure should be performed for all test frequencies to allow for proper software interpolation of frequencies between the test frequencies in the band (see [Figure 6-32](#) and [Figure 6-33](#)).

**NOTE:** Rx Front End Filter Alignment is required after replacing (or servicing) the transceiver board.

### 6.6.1 Procedure for UHF Range 1 (Auto Tune)

Tuning of the radio is done through **Rx Front End Filter** tuning screen

1. Select the **Rx Front End Filter** alignment screen. See [Figure 6-32](#).
2. Click on the slider or the "New Softpot Value" text box to select which frequency to tune.
3. Apply RF test signal input with no modulation at -14 dBm on the Test Signal Frequency displayed at the top of the screen.
4. Left-click the **Autotune** button.
5. Repeat the steps 2–4 for all frequencies.
6. Left-click the **Program All** button on the screen to save the tuned values in the radio.

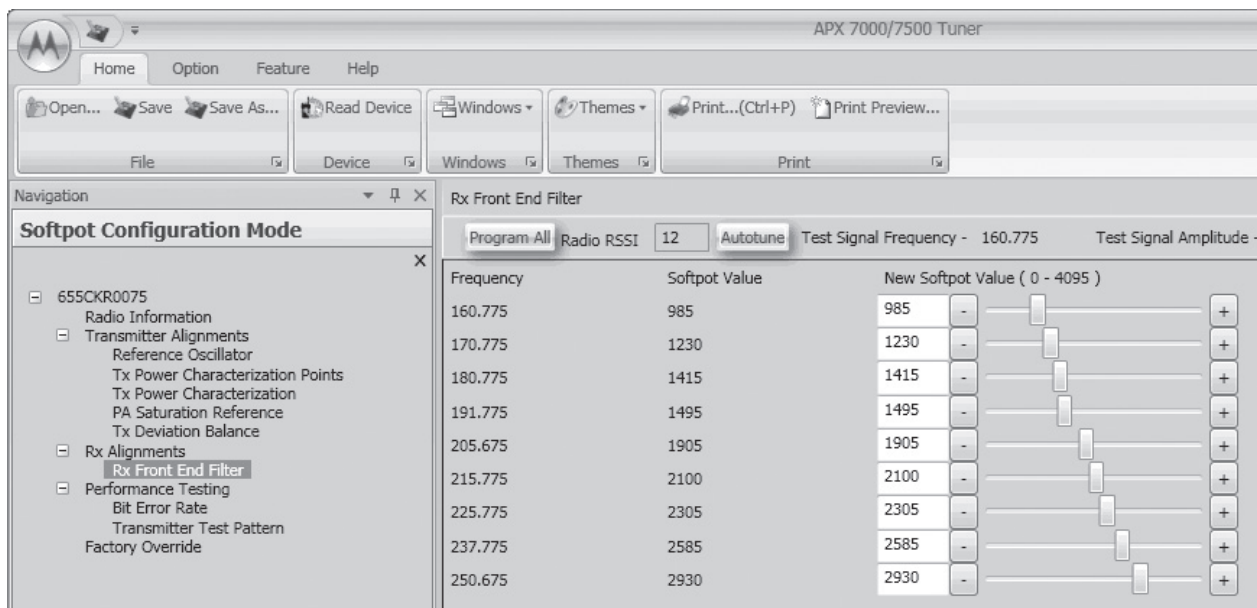

Figure 6-32. Front End Filter Alignment Screen (UHF1)

### 6.6.2 Procedure for UHF Range 2 (Auto Tune)

Tuning of the radio is done through **Rx Front End Filter** tuning screen

1. Select the **Rx Front End Filter** alignment screen. See [Figure 6-33](#).
2. Click on the slider or the "New Softpot Value" text box to select which frequency to tune.
3. Apply RF test signal input with no modulation at -14 dBm on the Test Signal Frequency displayed at the top of the screen.
4. Left-click the **Autotune** button.
5. Repeat the steps 2–4 for all frequencies.
6. Left-click the **Program All** button on the screen to save the tuned values in the radio.

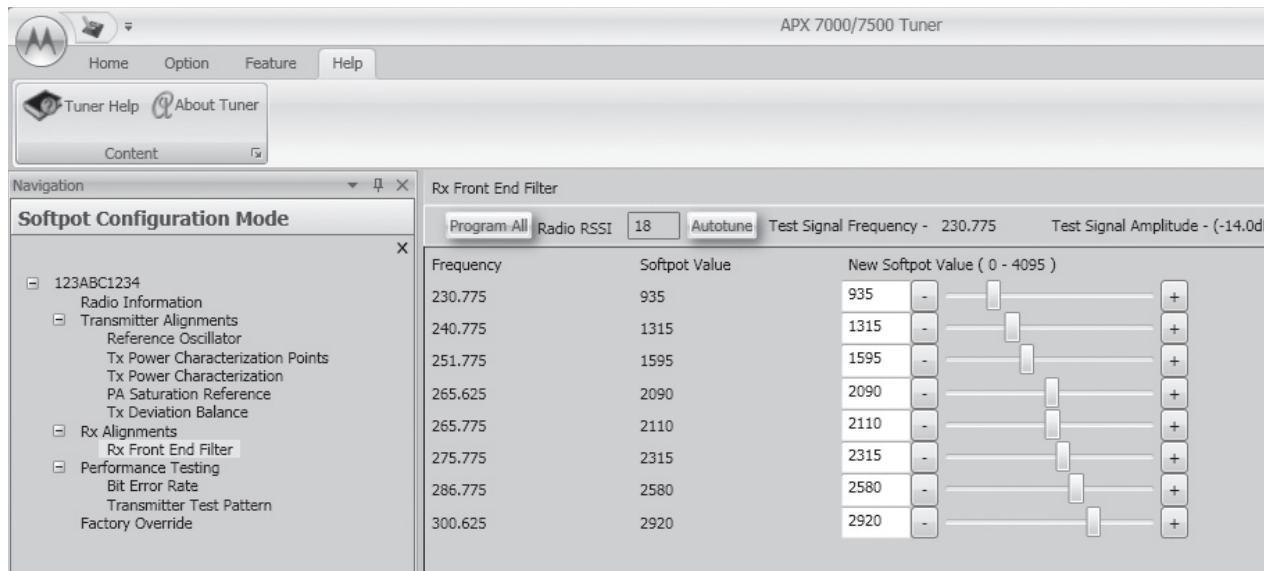

Figure 6-33. Front End Filter Alignment Screen (UHF2)

## 6.7 Performance Testing

### 6.7.1 Bit Error Rate

This section describes the Bit Error Rate (BER) test of the radio's receiver at a desired frequency (see [Figure 6-34](#)).

#### 6.7.1.1 Bit Error Rate Fields

Set up the R2670 Communication Analyzer as follows:

1. Connect the RF Input port of the radio under test to the RF IN/OUT port of the R2670 Service Monitor.
2. Set up the R2670 Service Monitor:
  - In the Display Zone, select PROJ 25 STD mode and set the meter to RF DISPLAY.
  - In the RF Zone, configure the analyzer as follows:

RF Control:	Generate
Preset:	B/W: NB
Freq:	Test frequency (Ex: 851.0625 MHz)
Output Level:	-50.0 dBm
Gen RF Out:	RF I/O
  - In the Audio Zone, select the 1011 Hz PAT code and set the deviation to "PROJ25Dev: 2.83 kHz ~".

The bit error rate screen contains the following fields:

- **Rx Frequency:**  
This field selects the Receive Frequency directly in MHz.
  - **Test Pattern:**  
This field selects the Digital test pattern to be received by the radio. Choices are: Standard Tone Test Pattern (Framed 1011), F2 1031 and Standard Interface Test Pattern (CCITT V.52).
  - **Modulation Type:**  
This field represents the digital modulation type of the incoming signal on which BER is to be calculated.
  - **Continuous Operation:**  
This field allows the user the option to repeat the BER test indefinitely. A selection of Yes will cause the radio to calculate BER on a continuous basis and update the results on this screen after each integration time. A selection of No will cause the BER test to execute for only one sample of the integration time and then update the display.
  - **Audio:**  
This field allows the user to select the audio output during a test. Selecting Internal will cause the radio's built-in speaker to unmute to any signals at the desired frequency which are present during the test. Selecting External will route the same signal to the radio's accessory connector audio output. Selecting Mute will disable the audio output.
- NOTE:** There will be **no audio** option available for APX 7000 when performing a Bit Error Rate Test.
- **BER Integration Time:**  
BER Integration Time carries with Test Pattern Type.
  - **Number of Frames**  
Number of Frames over which bit error result are accumulated to produce the result.

**NOTE:** When **Continuous Operation = Yes**, all fields will be grayed out while the test is in progress. They will be enabled when the STOP button is pressed.

When **Continuous Operation = No**, a wait cursor will be displayed while the test is in progress and return to normal when the test is done.

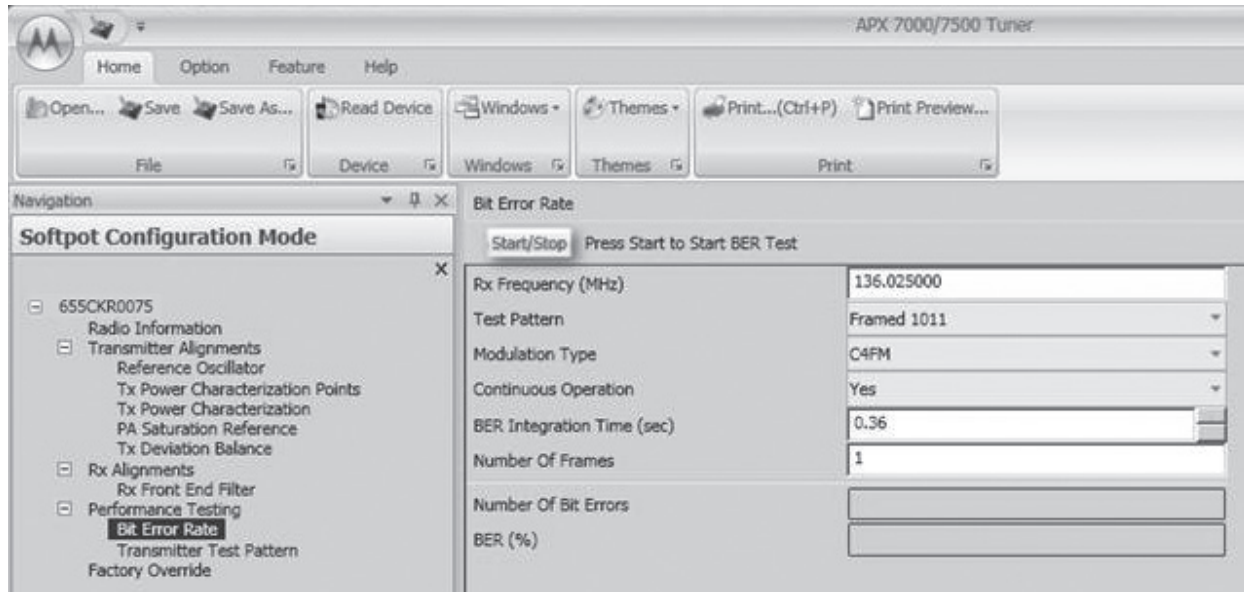

Figure 6-34. Bit Error Rate Screen

3. Press **Start/Stop** button to begin or end BER testing.

## 6.7.2 Transmitter Test Pattern

The Transmitter Test Pattern test is used to transmit specific test patterns at a desired frequency so that the user can perform tests on the radio's transmitter (see [Figure 6-35](#)).

### 6.7.2.1 Transmitter Test Fields

This screen contains the following fields:

- **Tx Frequency:**  
This field selects the Transmit Frequency directly in MHz.
- **Channel Spacing:**  
This field allows the user to select the desired channel spacing in kHz.
- **Test Pattern Type:**  
This field represents the type of test pattern which will be transmitted by the radio when **PTT TOGGLE** button is pressed.

**NOTE:** Channel Spacing and Test Pattern Type fields will be grayed out while radio is transmitting.

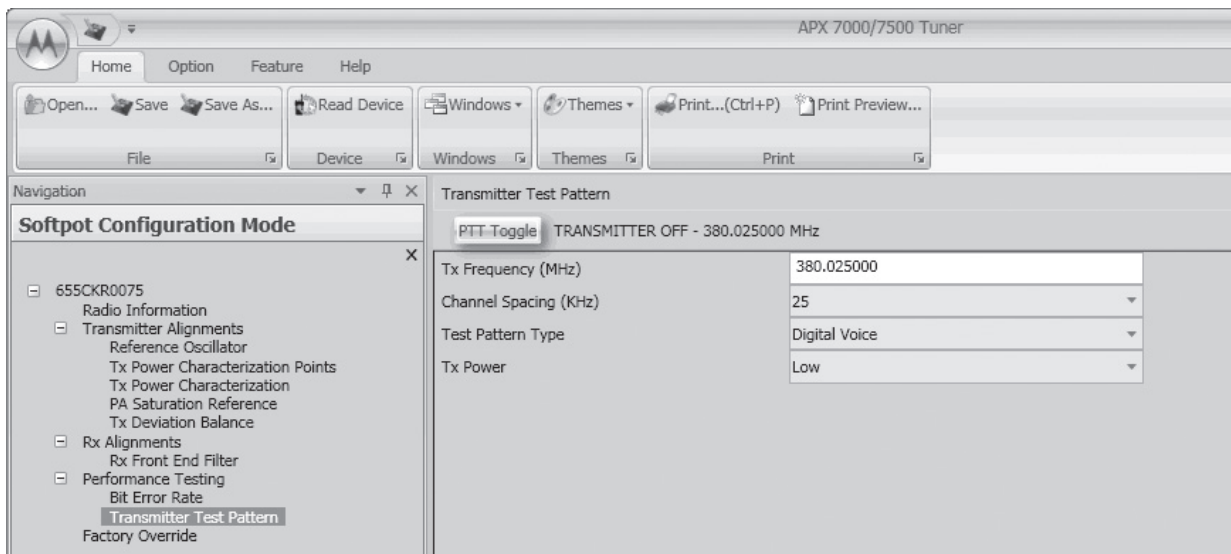

Figure 6-35. Transmitter Test Pattern Screen

## Notes

---

# Chapter 7 Encryption

This chapter provides procedures for using the encryption capability of your radio. The following procedures are outlined:

- Loading an encryption key
- Selecting an encryption key
- Selecting an Index (only applicable to Dual Display configured radios)
- Erasing an encryption key (only applicable to Dual Display configured radios)

## 7.1 Load an Encryption Key

Keys will be loaded from the KVL to the radio in either clear or encrypted form depending on the configuration of the CPS parameter "KVL – FIPS Level 3 Approved Mode". If the parameter is disabled, keys will be sent in clear form; if the parameter is enabled, keys will be sent to the radio in encrypted form.

**NOTE:** A KVL4000 or KVL3000 Plus with software version R03.52.45 or greater must be used to load keys to a radio with "KVL – FIPS Level 3 Approved Mode" enabled.

To load an encryption key:

1. Refer to the key-variable loader (KVL) manual for equipment connections and setup.
2. Attach the KVL to the radio. The top display shows "KEYLOAD" whereas "KEYLOADING" is shown on the front display of a Dual Display configured radio. All other radio functions, except for power down, backlight, and volume, are locked out.
3. Refer to the KVL manual for how to load the encryption keys into the radio.
4. When the key is loaded successfully, you will hear:
  - On single-key radios – a short tone.
  - On multikey radios – an alternating tone.

## 7.2 Multikey Feature

This feature allows the radio to be equipped with multiple encryption keys. It can support two or more encryption algorithms simultaneously (e.g., AES and DES-XL).

- **Conventional Multikey** – The encryption keys can be tied (strapped), on a one-per-channel basis. In addition, the radio can have operator-selectable keys, operator-selectable indices, and operator-selectable key erasure. If talkgroups are enabled in conventional, then the encryption keys are strapped to the talkgroups.
- **Trunked Multikey** – If the radio is used for both conventional and trunked applications, strap the encryption keys for trunking on a per- talkgroup or announcement group basis. In addition, a different key can be strapped to other features; for example, dynamic regrouping, failsoft, or emergency talkgroup. The radio can have operator-selectable key erasure.

## 7.3 Select an Encryption Key

You can select an encryption key using either the menu or the keypad.

### 7.3.1 Use the Menu

To select an encryption key using the menu:

1. Press **▶** until the display shows “KEY”.
2. Press **◀**, **▶**, or **⏏** directly below “KEY”. The display shows the last user-selected and -stored encryption key, as well as the available menu selections.
3. Press **◀** or **▶** to scroll through the list of encryption keys.
 

**NOTE:** If you select an erased key, the display alternates between showing the encryption key and “ERASED KEY”.
4. Press **◀**, **▶**, or **⏏** directly below the desired menu.
  - PSET = selects the preset or default encryption key.
  - SEL = saves the newly selected key and returns to the home display.
5. Press **⏏**, the **PTT** button, or **◀**, **▶**, or **⏏** directly below the ABRT menu, or turn the **16-Position Select** knob to exit this menu.
  - If the selected key is erased, the display shows “KEY FAIL” and the radio sounds a momentary keyfail tone.
  - If the selected key is not allowed, the display shows “ILLEGAL KEY” and the radio sounds a momentary illegal key tone.

### 7.3.2 Use the Keypad

To select an encryption key using the keypad:

1. Press **▶** until the display shows “KEY”.
2. Press **◀**, **▶**, or **⏏** directly below “KEY”. The display shows the last user-selected and stored encryption key, as well as the available menu selections.
3. Using the keypad, enter the number of the desired key.
 

**NOTE:** If you select an erased key, the display alternates between showing the encryption key and “ERASED KEY”.
4. Press **◀** or **▶** to select from the menu.
  - PSET = selects the preset or default encryption key.
  - SEL = saves the newly selected key and returns to the home display.
5. Press **⏏**, the **PTT** button, or **◀**, **▶**, or **⏏** directly below the ABRT menu, or turn the **16-Position Select** knob to exit this menu.
  - If the selected key is erased, the display shows “KEY FAIL” and the radio sounds a momentary keyfail tone.
  - If the selected key is not allowed, the display shows “ILLEGAL KEY” and the radio sounds a momentary illegal key tone.



## 7.4 Select an Encryption Index

This feature lets the user select one or more groups of several encryption keys from among the available keys stored in the radio. For example, the radio could have a group of three keys structured to one index, and another group of three different keys structured to another index. Changing indices makes the radio automatically switch from one set of keys to the other. Every channel to which one of the original keys was tied will now have the equivalent new key instead.

### 7.4.1 Use the Menu

To select an index using the menu:

1. Press **▶** until the display shows “INDX”.
2. Press **◀**, **▶**, or **⏏** directly below “INDX”. The display shows the last user-selected and -stored index, as well as the available index menu selections.
3. Press **◀**, **▶**, or **⏏** directly below the desired index. The display shows the last user-selected and -stored index, as well as the available index menu selections.
4. Choose one of the following:
  - a. To save the index, press **◀**, **▶**, or **⏏** directly below “SEL”.
  - b. To exit this menu without changing the index selection, press **⏏** or the **PTT** button, or turn the **16-Position Select** knob.

### 7.4.2 Use the Keypad

To select an index using the keypad:

1. Press **▶** until the display shows “INDX”.
2. Press **◀**, **▶**, or **⏏** directly below “INDX”. The display shows the last user-selected and -stored index, as well as the available index menu selections.
3. Using the keypad, enter the number of the desired index.
4. Choose one of the following:
  - a. To save the index, press **◀**, **▶**, or **⏏** directly below “SEL”.
  - b. To exit this menu without changing the index selection, press **⏏** or the **PTT** button, or turn the **16-Position Select** knob.

## 7.5 Erase an Encryption Key

This section describes two methods for erasing an encryption key.

### 7.5.1 Method 1 – Key Zeroization (Multikey Only)

To zeroize an encryption key:





1. Press **▶** until the display shows “ERAS”.
2. Press **◀**, **▶**, or **⏏** directly below “ERAS”. The display shows the last user-selected and -stored encryption key, as well as the available menu selections that are listed in [Table 7-1](#).
3. Choose one of the following:
  - If you want to erase all the encryption keys at once, go to step 4 below.
  - If you want to erase a single encryption key, do one of the following:

- Press ◀ or ▶ to find the desired key. The display shows the selected key and the available menu selections shown in [Table 7-1](#).
- Using the keypad, enter the location number of the desired key. The display shows the selected key, as well as the available menu selections shown in [Table 7-1](#).

Table 7-1. Encryption Key Zeroization Options

Menu Selection	Action
ALL	Erases all the encryption keys in the radio. The display shows "ERS ALL KEYS" and "YES" and "NO".
SNGL	Selects the displayed encryption key to be erased. The display shows "ERS SNGL KEY" and "YES" and "NO".
ABRT	Exits this menu and returns to the home display

**NOTE:** To exit this menu at any time without erasing the key selection, press  or the **PTT** button, or turn the **16-Position Select** knob.

4. Press , , or  directly below the desired menu selection.
5. Press , the **PTT** button, or turn the **16-Position Select** knob to exit this menu.

### 7.5.2 Method 2 – All Keys Erased

To erase all encryption keys at one time:

With the radio on, press and hold the **Top Side** button and, while holding this button down, press the **Top** button.

**NOTE: DO NOT** press the **Top** button before pressing the **Top Side** button unless you are in an emergency situation. This sends an emergency alarm.

Before the keys are erased, the display shows "PLEASE WAIT".

When all the encryption keys have been erased, the display shows "ALL KEYS ERASED".

---

## Chapter 8 Disassembly/Reassembly Procedures

This chapter provides detailed procedures for disassembling/reassembling and ensuring submergibility of the APX 7000 (R) radios. When performing these procedures, refer to “[Chapter 10. Exploded Views and Parts Lists](#)” on page 1:10-1 and the diagrams that accompany the text. Items in parentheses ( ) throughout this chapter refer to item numbers in the exploded view diagrams and their associated parts lists.

This chapter also has procedures for removing and installing the APX 7000 radio’s standard accessories and changing the Volume and Frequency Knobs.

### 8.1 APX 7000 Exploded View (Main Subassemblies)

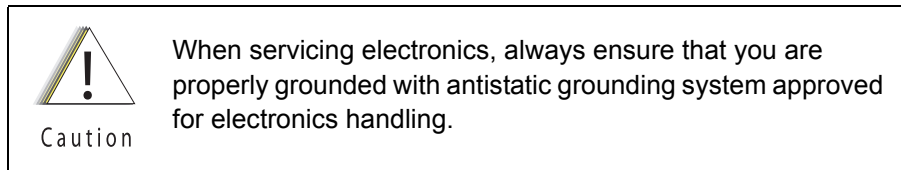

This section contains the APX 7000 radio partially exploded views.

#### NOTES:

- Refer to [Figure 8-1](#) and [Figure 8-2](#), the Dual Display and Top Display Partial Exploded Views, and [Table 8-1](#), the Partial Exploded View Parts List.
- Letters in parentheses ( ) refer to item letters in [Figure 8-1](#), [Figure 8-2](#) and [Table 8-1](#).

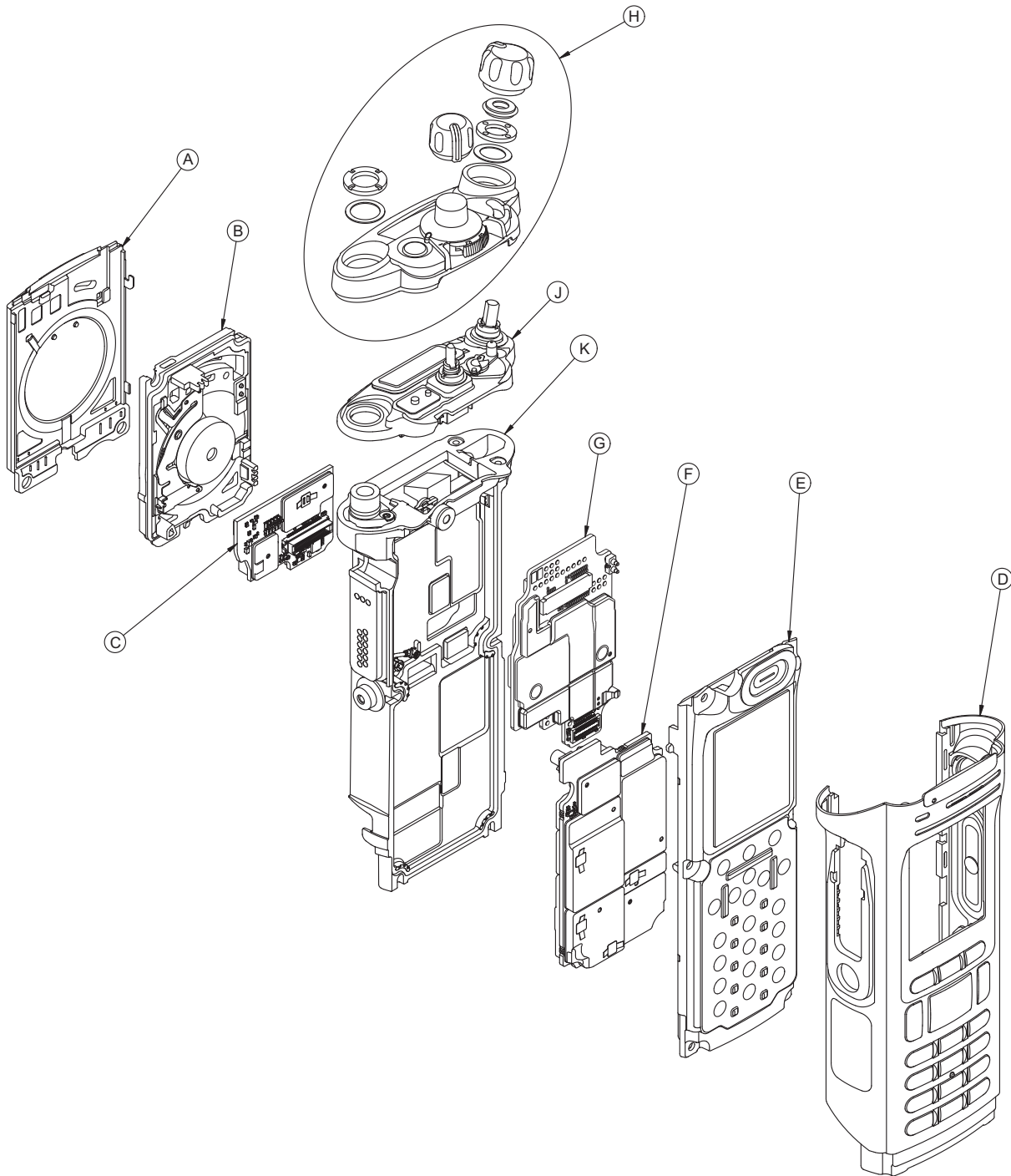
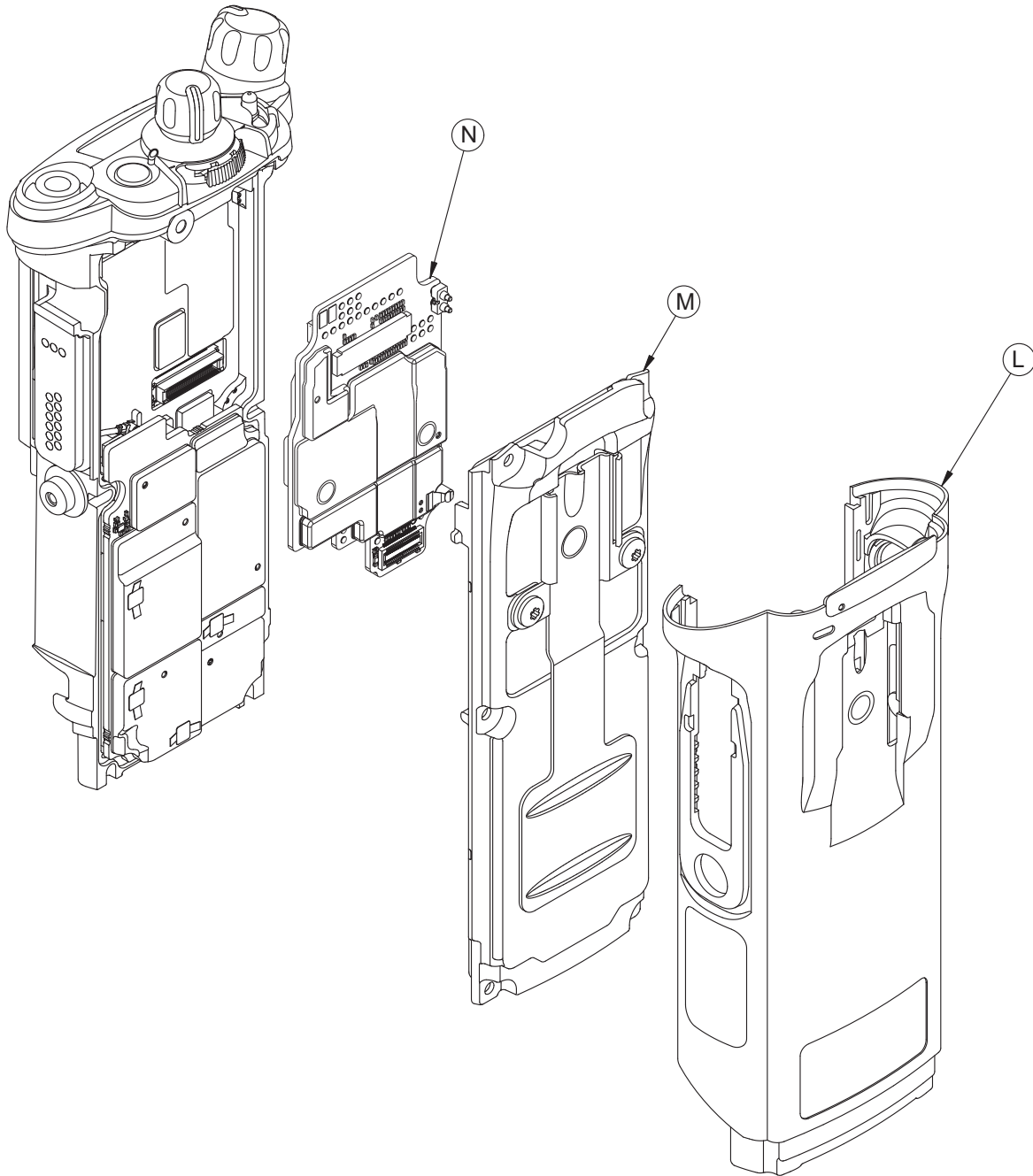

Figure 8-1. APX 7000 Dual Display Partial Exploded View



**NOTE:** All common parts are shown on the APX 7000 Dual Display Partial Exploded View.

*Figure 8-2. APX 7000 Top Display Partial Exploded View*

Table 8-1. APX 7000 Partial Exploded View Parts List

Item Letter	Description	Exploded View and Parts List
A	Speaker Grille Assembly	Refer <a href="#">Figure 10-1: "APX 7000 Dual Display Exploded View"</a> on page 1:10-2.
B	Speaker Module	Refer <a href="#">Figure 10-1: "APX 7000 Dual Display Exploded View"</a> on page 1:10-2.
C	Expansion Board Assembly	Refer <a href="#">Figure 10-1: "APX 7000 Dual Display Exploded View"</a> on page 1:10-2.
D	Main Housing Assembly (Dual Display)	Refer <a href="#">Figure 10-1: "APX 7000 Dual Display Exploded View"</a> on page 1:10-2.
E	Back Chassis Assembly (Dual Display)	Refer <a href="#">Figure 10-1: "APX 7000 Dual Display Exploded View"</a> on page 1:10-2.
F	RF Board Assembly	Refer <a href="#">Figure 10-1: "APX 7000 Dual Display Exploded View"</a> on page 1:10-2.
G	VOCON Board Assembly (Dual Display)	Refer <a href="#">Figure 10-1: "APX 7000 Dual Display Exploded View"</a> on page 1:10-2.
H	Knobs & Top Bezel Assembly	Refer <a href="#">Figure 10-1: "APX 7000 Dual Display Exploded View"</a> on page 1:10-2.
J	Control Top Assembly	Refer <a href="#">Figure 10-1: "APX 7000 Dual Display Exploded View"</a> on page 1:10-2.
K	Main Chassis Assembly	Refer <a href="#">Figure 10-1: "APX 7000 Dual Display Exploded View"</a> on page 1:10-2.
L	Main Housing Assembly (Top Display)	Refer <a href="#">Figure 10-2: "APX 7000 Top Display Exploded View"</a> on page 1:10-4.
M	Back Chassis Assembly (Top Display)	Refer <a href="#">Figure 10-2: "APX 7000 Top Display Exploded View"</a> on page 1:10-4.
N	VOCON Board Assembly (Top Display)	Refer <a href="#">Figure 10-2: "APX 7000 Top Display Exploded View"</a> on page 1:10-4.
O	Bluetooth Option Board	Refer <a href="#">Figure 10-2: "APX 7000 Top Display Exploded View"</a> on page 1:10-4.

## 8.2 Required Tools and Supplies

Table 8-2. Required Tools and Supplies

Tools	Motorola Part Number	Supplier	Supplier Part Number	Remarks
Bit, Torx IP8	–	–	–	Torx T8 may be used, but Torx Plus IP8 is recommended
Bit, Volume Spanner Nut	66009256001	Motorola	–	
Bit, Antenna Spanner	66009258001	Motorola	–	
Black Stick	–	Hexacon Electric Co.	MA-800G	
Seater, Secure Lever	66009261001	Motorola	–	
Driver, Torque	–	–	–	
Vacuum Pump Kit	NLN9839_	Motorola	–	For Vacuum Test
Grille Eliminator	66009255001	Motorola	–	For Vacuum Test and Pressure Test
Vacuum Adapter	66009259001	Motorola	–	For Vacuum Test and Pressure Test
Pressure Pump Kit	NTN4265_	Motorola	–	For Pressure Test

## 8.3 Fastener Torque Chart

Table 8-3 lists the various fasteners by part number and description, followed by the torque values and the location where used. Torque all fasteners to the recommended value when assembling the radio.

Table 8-3. Required Tools and Supplies

Motorola Part Number	Description	Repair Torque (in-lbs)
0275361H01	Volume Spanner Nut (17)	8
0275891B01	Antenna Spanner Nut (19)	16
0375962B01	Top Screw (28)	10
0375962B02	Center Screw (29)	10
0375962B03	Bottom Screw (30)	10
0375962B04	Control Top Screw (31)	8

## 8.4 Antenna

This section explains how to attach and remove the antenna.

### 8.4.1 Attach Antenna

To attach the antenna:

With the radio turned off, turn the antenna clockwise to attach it to the radio.

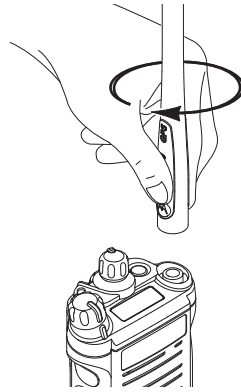
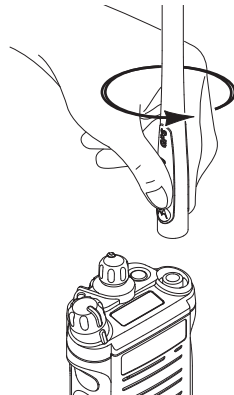

*Figure 8-3. Attaching the Antenna*

### 8.4.2 Remove Antenna

To remove the antenna:

With the radio turned off, turn the antenna counter-clockwise to remove it from the radio.



*Figure 8-4. Removing the Antenna*



## 8.5 Battery

This section explains how to properly attach and remove the battery.



WARNING

**To avoid a possible explosion:**

- **DO NOT** charge, remove, or attach the battery in an area labeled “hazardous atmosphere.”
- **DO NOT** discard batteries in a fire.



Caution

If the radio is programmed for volatile-key retention, encryption keys will be retained for approximately 30 seconds after battery removal.

**NOTE:** The Motorola-approved battery shipped with the APX 7000 radio is uncharged. Prior to using a new battery, charge it per the recommended procedure for the battery.

### 8.5.1 Attach Battery

To attach the battery:

1. With the radio turned off, verify that the battery seal is set properly in its groove as shown in [Figure 8-5](#).

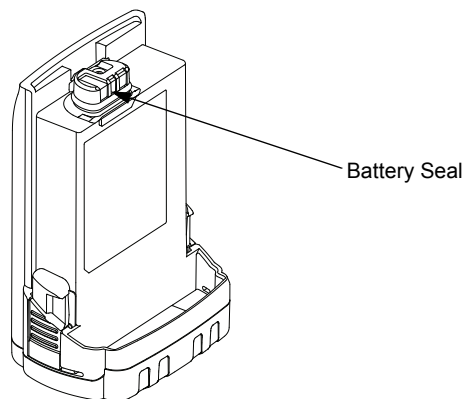

*Figure 8-5. Attaching Battery – Battery Seal*

2. Verify that the Memory Door (33) is closed by ensuring the door is fully seated and the catch feature on the tab is in the main chassis notch.

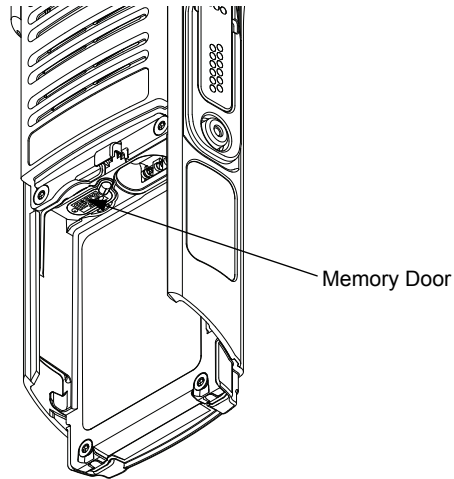

Figure 8-6. Attaching Battery – Memory Door

3. Set the battery onto the chassis as shown in [Figure 8-7](#). and slide into position. Make sure both battery latches click into position.

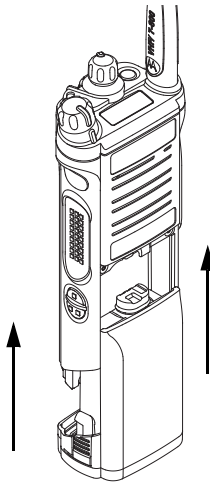
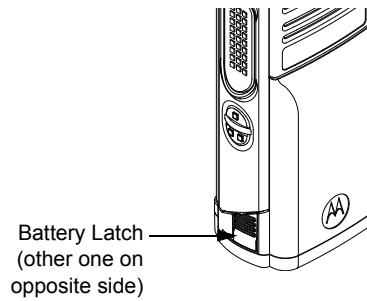

Figure 8-7. Attaching Battery – Slide into Position

## 8.5.2 Remove Battery

To remove the battery:

1. With the radio turned off, squeeze the two latches located near the bottom, on the sides of the battery.



*Figure 8-8. Squeezing the Release Latches*

2. While squeezing the latches, remove the battery by sliding it out as shown.

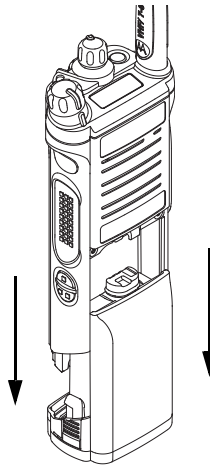

*Figure 8-9. Removing the Battery*

## 8.6 Universal Connector Cover

This section explains how to remove and attach the Universal Connector Cover (43).



Caution

When the universal connector is not in use, keep it covered with the Universal Connector Cover.

### 8.6.1 Remove Universal Connector Cover

To remove the Universal Connector Cover (43):

1. Unscrew the thumb screw. If the screw is too tight a hex driver may be used.

**NOTE:** Do not remove the screw. It should remain captive in the cover.

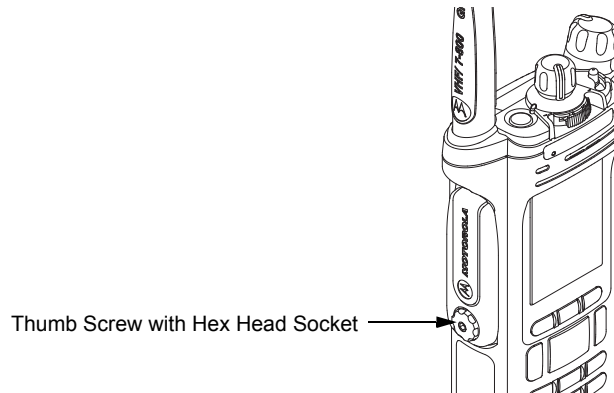

Figure 8-10. Removing the Thumb Screw

2. Slightly swing the Universal Connector Cover away from radio before sliding it upward to disengage the hook feature.
3. Pull the Universal Connector Cover away from the radio.

## 8.6.2 Attach Universal Connector Cover

To attach the Universal Connector Cover:

1. Insert the hooked end of the cover into the pocket. Engage the hook beneath the undercut and swing the cover down onto the radio. Ensure the cover is seated properly and the screw is aligned into the threaded hole.

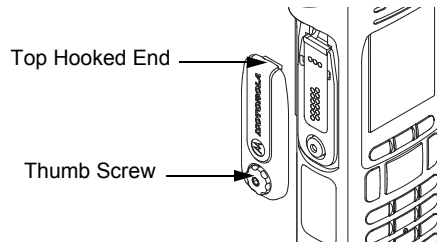

Figure 8-11. Engaging Hook and Seating Cover

2. Hand tighten the thumb screw clockwise until secured.

**NOTE:** Do not overtighten the screw. The screw should be snugged and not allow the cover to move.

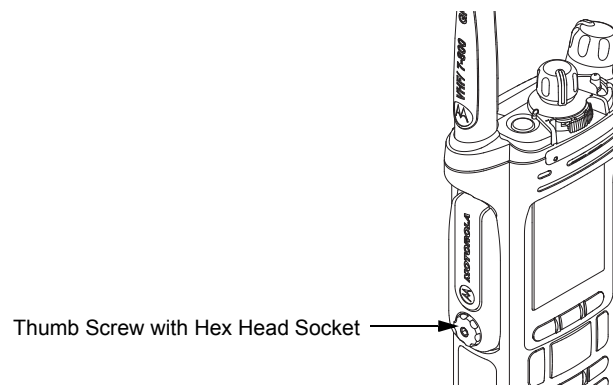

Figure 8-12. Securing the Cover

## 8.7 Radio Disassembly

This section contains instructions for disassembling the radio's main subassemblies.

### Prepare the radio for disassembly:

- Turn off the radio by rotating the On/Off/Volume Knob (12) fully counterclockwise until a click is heard.
- Remove the antenna, the battery, any memory card, Belt Clip Cover (48) (Top Display Only), the Universal Connector Cover (43) and any other accessory connected to the radio.

### 8.7.1 Removal of the Speaker Grille Assemblies (A)

1. With the Battery removed and the primary loudspeaker side of the radio facing you, remove the center two screws (29) and swing out Speaker Grille Assembly (A) as shown in [Figure 8-13](#).

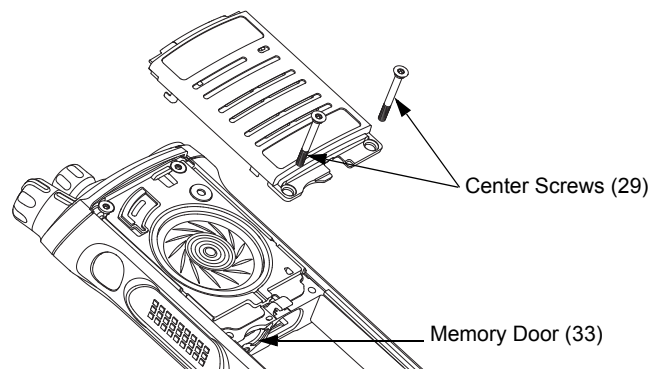

Figure 8-13. Remove Center Screws

**NOTE:** Memory Door (33) can be removed with the left center screw removed.

2. Remove the bottom two screws (30) if the Main Housing Assembly (D, L) is to be removed. Refer [Figure 8-14](#).

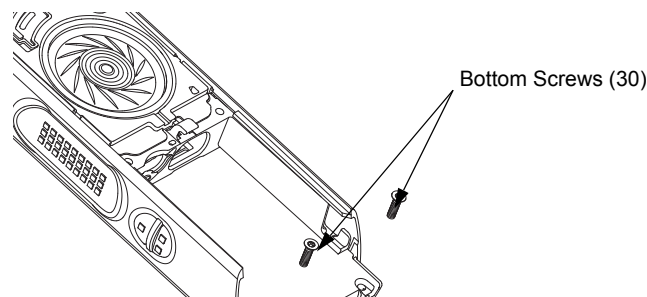

Figure 8-14. Remove Bottom Screws

**NOTE:** Once the screws have been removed, both Thermal Pads (39, 40) should be replaced.



Caution

Do not touch either the speaker cone or the Port Seal (25). Take extra precaution to make sure neither the speaker nor the breather pad is damaged.

### 8.7.2 Removal of the Speaker Module (B)

1. Remove the top two screws (28) as shown in [Figure 8-15](#).

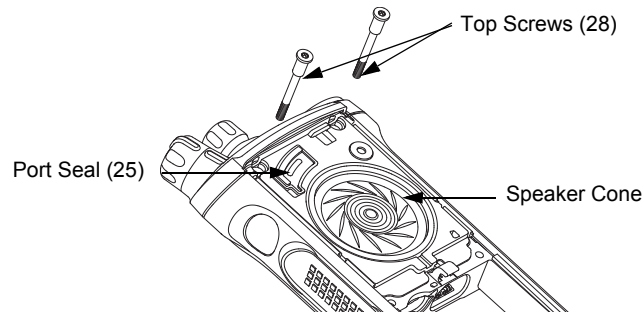

Figure 8-15. Remove Top Screws

2. Carefully pick out the Speaker Module (23) with the Black Stick and swing it out of the Main Chassis Assembly (K) as shown in [Figure 8-16](#).

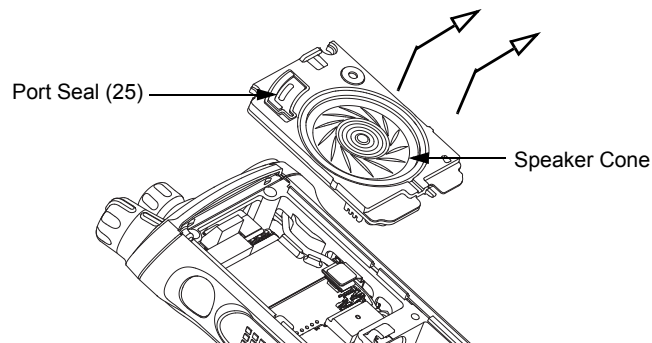

Figure 8-16. Remove Speaker Module



Caution

Be careful not to damage the speaker cone or the Port Seal (25) during the disassembly process.

This Module has lubricant on the seal and can be contaminated with foreign material. Any foreign material can put the radio's submergibility at risk.

### 8.7.3 Removal of the Expansion Board Assembly (C)

1. Using the Black Stick, unplug the two flex connectors located on the left and right side of the Expansion Board Assembly (42). Unfold and straighten the flex located on the right side as shown in [Figure 8-17](#).

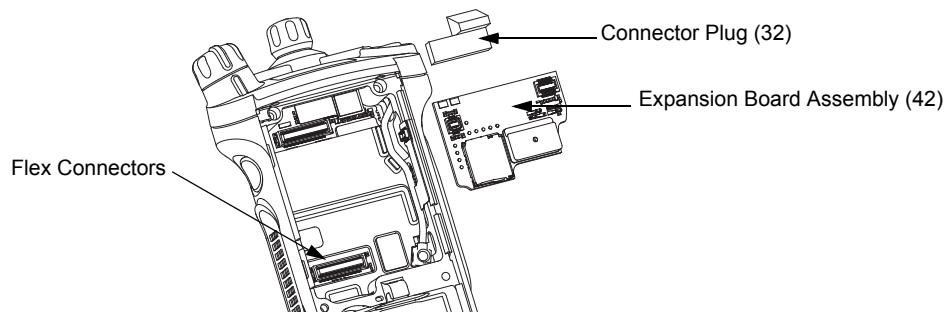
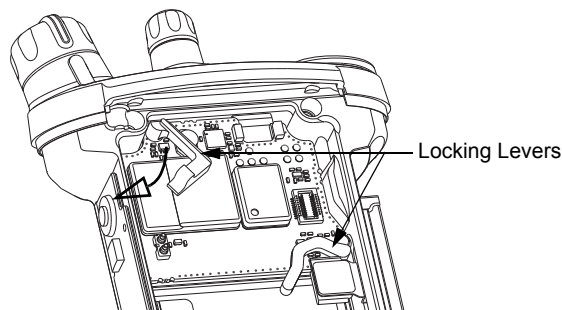

*Figure 8-17. Remove Flex Connectors and Expansion Board Assembly*

2. Remove the Expansion Board Assembly (C) by gently lifting up the right side of the PCB as shown in [Figure 8-17](#).
3. If the VOCON Board Assembly (G, O) is to be removed from the Control Top Assembly (J), then remove the Connector Plug (32) with the Black Stick and unplug the Control Top Assembly flex as shown in [Figure 8-17](#).

If the radio is equipped with an Bluetooth Option Board Assembly in lieu of the Connector Plug (32):

- i. rotate the Bluetooth Option Board locking levers to unlock the option board and free it for removal as shown in [Figure 8-18](#).



*Figure 8-18. Unlock Levers*

- ii. unplug the Bluetooth Option Board Assembly from the VOCON Board Assembly by using the Black Stick as shown in [Figure 8-19](#).

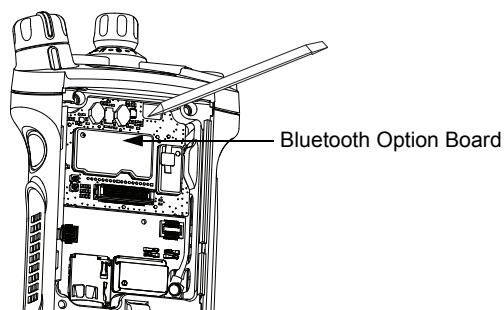

*Figure 8-19. Remove Bluetooth Option Board*



4. If the RF Board Assembly (F) is to be removed, use the Black Stick to unplug the antenna coax cable from the RF Board Assembly as shown in [Figure 8-20](#).

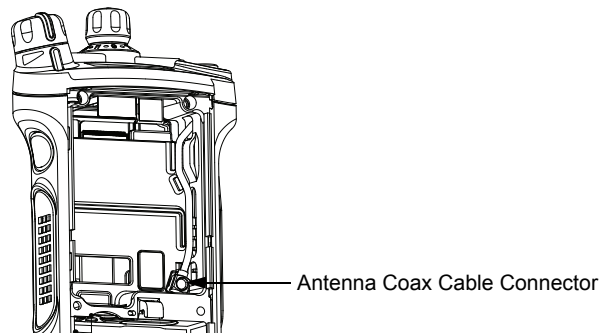

*Figure 8-20. Remove Antenna Coax Cable Connector*

5. Flip the radio over.

#### **8.7.4 Removal of the Main Housing Assembly (D)**

1. Gently stretch both sides of the Main Housing Assembly (1) outwards to clear the radio. Then lift it over the radio as shown in [Figure 8-21](#).

**NOTE:** For Top Display version, ensure the Belt Clip Cover (48) has been removed.

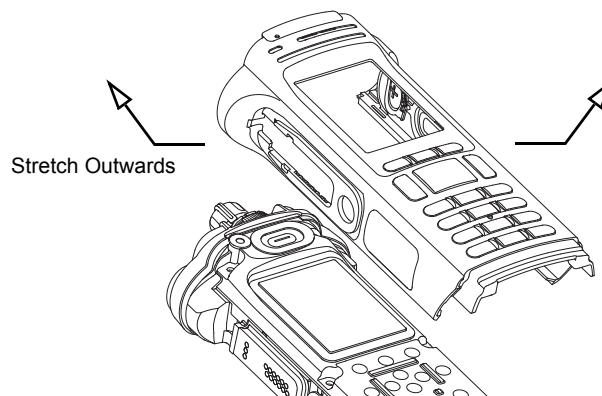

*Figure 8-21. Remove Housing*

### 8.7.5 Removal of the Back Chassis Assembly (E, M)

1. Dual Display version:

Gently separate the Back Chassis Assembly (E) from the Main Chassis Assembly (K) to allow access to disconnect the flex connection between both chassis. This connector is located near the top of the radio. Use the Black Stick to disconnect the connector as shown in [Figure 8-22](#).

Top Display version:

Back Chassis Assembly (M) has no connections and can be removed by just separating the the two chassis apart.

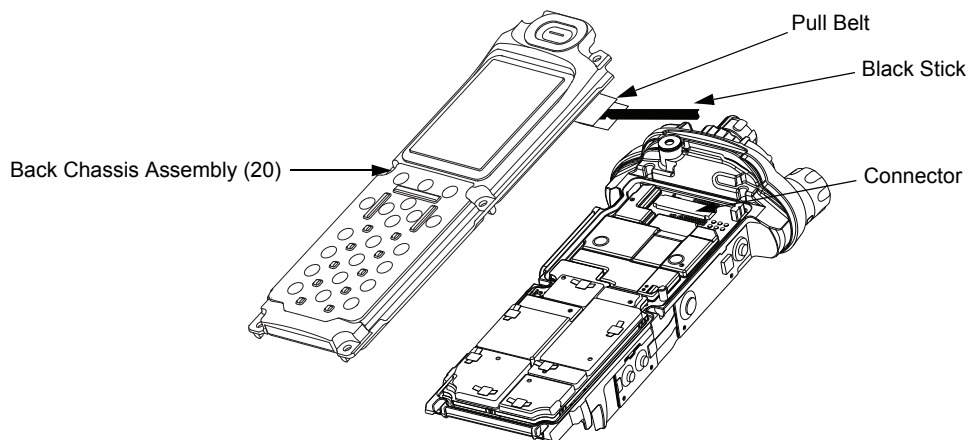
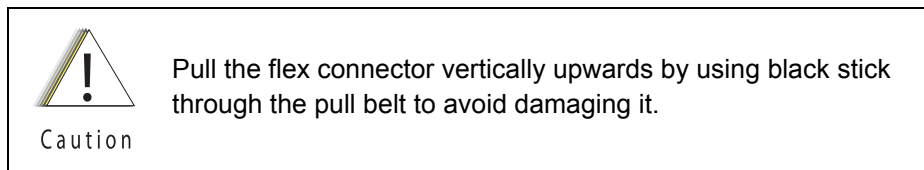

Figure 8-22. Remove Back Chassis Assembly from Main Chassis Assembly

### 8.7.6 Removal of the RF Board Assembly (F)

**NOTE:** Reconfirm the coax cable connector on the bottom side of the RF Board is disconnected before removing the RF Board.

1. Unplug the RF Board Assembly (F) from the VOCON Board Assembly (G, O) by using the Black Stick. Slowly lift the RF Board Assembly enough to allow access to the small coax cable. Unplug the small coax cable using a Black Stick or a pair of small tweezers.



Caution

Place the RF Board Assembly in a clean and ESD safe area to avoid contamination to the Battery Connector Seal (41) and electrical damage to the electronics respectively.

Replace Thermal Pads (39, 40) whenever RF Board Assembly is removed.

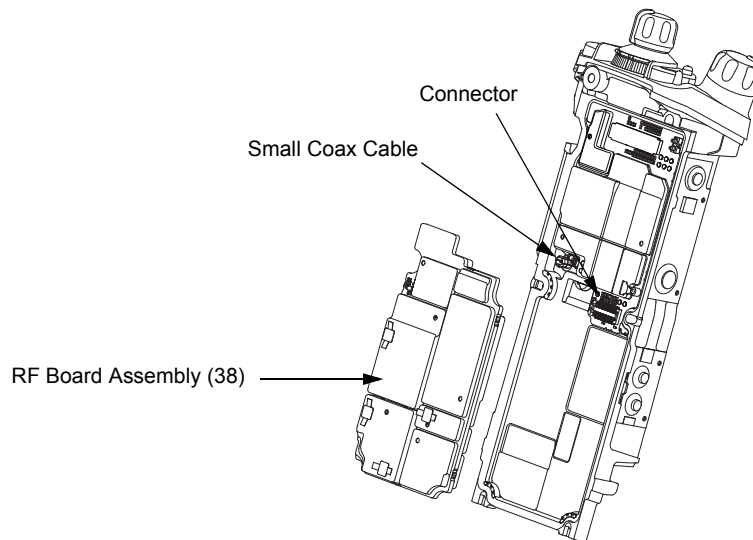

Figure 8-23. Remove RF Board Assembly

### 8.7.7 Removal of the VOCON Board Assembly (G, O)

**NOTE:** Reconfirm the Flex connector between the Control Top Assembly (J) and the VOCON Board Assembly (G, O) or, if so equipped, the Bluetooth Option Board is disconnected (see [step 3 on page 1:8-14](#)). Failure to do so may damage the connectors or the flex.

1. Gently rotate the VOCON Board Assembly just enough to clear the Main Chassis and Bluetooth Option Board connector. Slide out the VOCON Board Assembly as shown in [Figure 8-24](#).

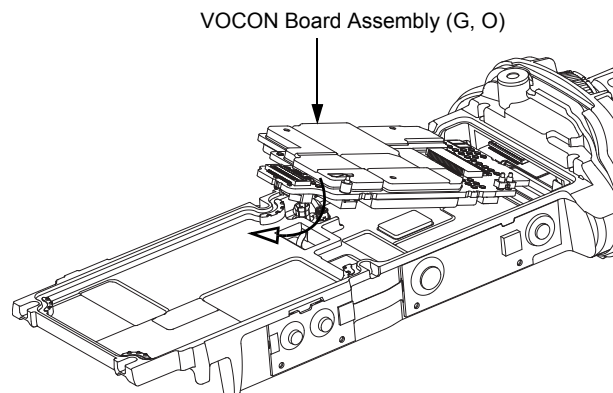

Figure 8-24. Remove VOCON Board Assembly

### 8.7.8 Removal of the Knobs & Top Bezel Assembly (H)

#### A. Remove the Frequency Knob

To remove the Frequency Knob (13):

1. Hold the radio in one hand so that the top of the radio faces upward, and the front of the radio faces you.
2. With the other hand, grasp the Frequency Knob and pull it upward, until it is free from its shaft.

#### B. Remove the Volume Knob

To remove the Volume Knob (12):

1. Hold the radio in one hand so that the top of the radio faces upward and the front of the radio faces you.
2. With the other hand, grasp the Volume Knob and pull it upward.
  - i. Remove the Torque Adder (15) with the Black Stick.
  - ii. Unscrew the Volume Spanner Nut (17) using the Volume Spanner Bit with a driver. Remove the Volume Washer (16) below the nut.
  - iii. Unscrew the Antenna Spanner Nut (19) with the Antenna Spanner Bit and a driver. Remove the Antenna Washer (18) below the nut as shown in [Figure 8-25](#).

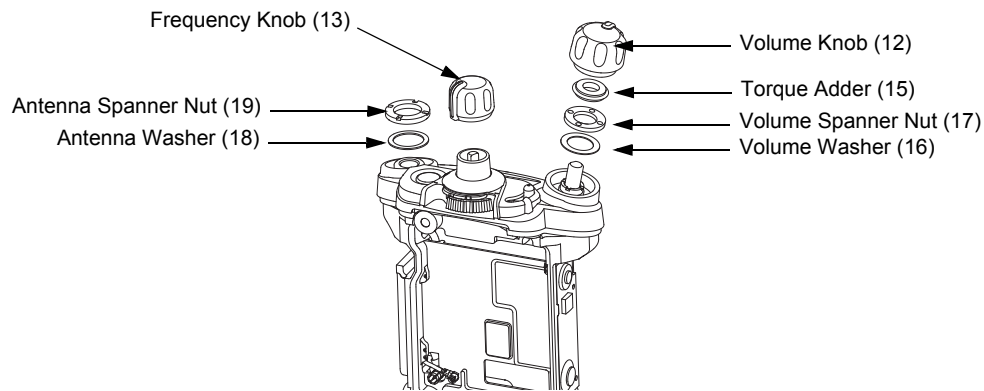

Figure 8-25. Remove Knobs and Fastener Hardware

- iv. Gently lift the Control Top Bezel Assembly (11) and with the aid of the Black Stick, pop the Secure Lever (14) off the Frequency shaft as shown in Figure 8-26.

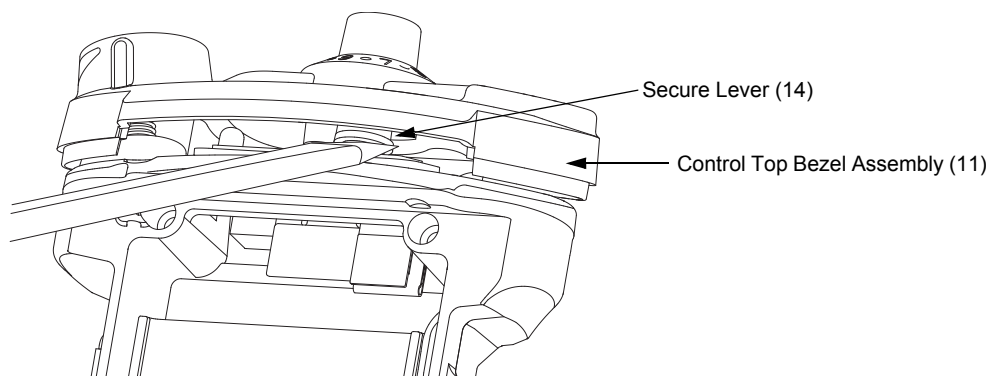

Figure 8-26. Remove Control Top Bezel Assembly

### 8.7.9 Removal of the Control Top Assembly (J)

- i. Use a Torx Plus IP8 bit to remove the two Control Top Screws (31). See Figure 8-27.

**NOTE:** Ensure the Control Top flex is disconnected from the VOCON Board (G, O) to prevent damage to the flex or connector.

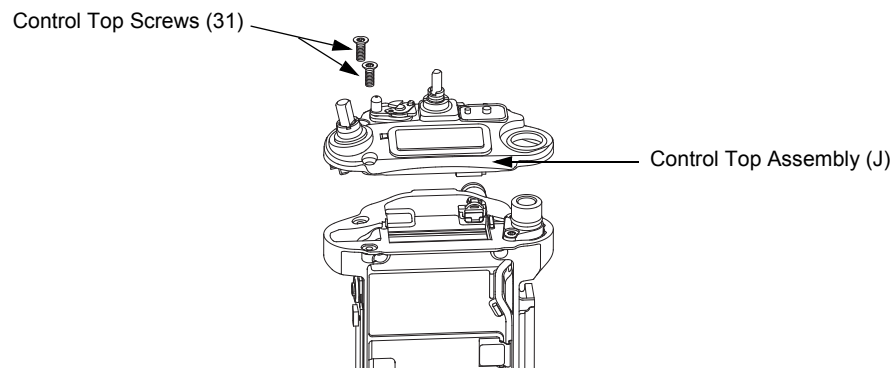

Figure 8-27. Remove Control Top Assembly (9)

- II. Gently separate the Control Top Assembly (J) from the Main Chassis Assembly (K).

**NOTE:** Place the Control Top Assembly (J) and the remaining Main Chassis Assembly (K) on an ESD safe surface free from debris.

## 8.8 Serviceable Components of the Main Sub-Assemblies

### 8.8.1 Servicing Main Chassis Assembly (K)

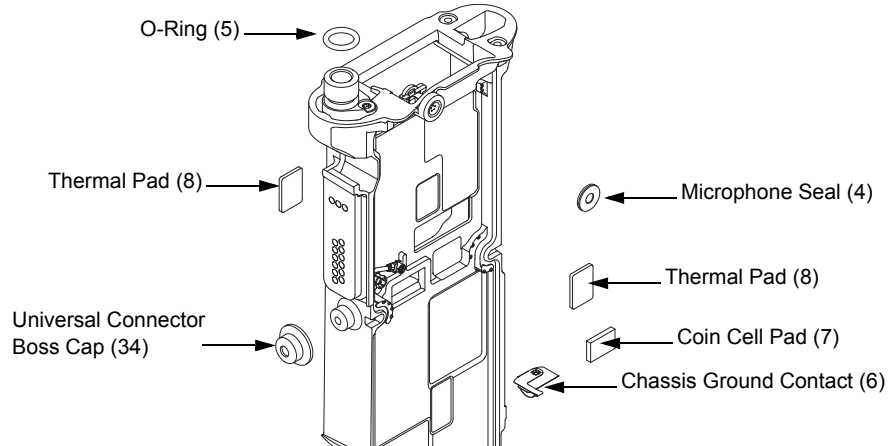

Figure 8-28. Serviceable Components – Main Chassis Assembly

#### 8.8.1.1 Servicing Chassis Pads:

1. Complete steps from [Section 8.7.1.](#) through [Section 8.7.9.](#) of [Section “8.7 Radio Disassembly”](#) on [page 1:8-12.](#)
2. Carefully peel off the pad(s) that need replacing (i.e. VOCON Pad (8), Expansion Board Pad (8) and/or Coin Cell Pad (7) from the chassis.
3. Use the Black Stick to help remove any difficult sections of the pad(s).
4. Clean the area once the pad(s) are removed to ensure it is free of adhesive and debris.
5. Peel the liner off the new pad(s) and place in the respective location.
6. Apply slight pressure to set the adhesive.

#### 8.8.1.2 Servicing Chassis Screw Boss Cap:

1. Complete steps from [Section 8.7.1.](#) through [Section 8.7.4.](#) of [Section “8.7 Radio Disassembly”](#) on [page 1:8-12.](#)
2. Carefully pry off the Universal Connector Boss Cap (34) with the Black Stick from the Main Chassis Assembly (3) as shown in [Figure 8-28.](#)
3. Press the new Cap down onto the boss until it is fully seated.

**NOTE:** There should be no gap between the chassis boss top face and the corresponding interior surface of the cap.

### 8.8.1.3 Servicing Antenna O-ring:

1. Complete steps from [Section 8.7.1.](#) through [Section 8.7.9.](#) of [Section "8.7 Radio Disassembly" on page 1:8-12.](#)
2. Remove the O-ring (5) with the Black Stick.
3. Reinstall the O-ring by rolling it over the threaded portion of the antenna hub until it sets in its groove.

**NOTE:** Ensure the O-ring is not twisted.

### 8.8.1.4 Servicing Microphone Membrane

1. Complete steps from [Section 8.7.1.](#) through [Section 8.7.4.](#) of [Section "8.7 Radio Disassembly" on page 1:8-12.](#)
2. Carefully peel off the Microphone Membrane (4) from the Main Chassis Assembly (3).
3. Clean the area, once the Microphone Membrane is removed, to ensure it is free of adhesive and debris. Ensure nothing comes in contact with the microphone while cleaning.
4. Remove the backer from the Microphone Membrane.
5. Carefully place the Microphone Membrane centered on the top surface of the microphone boss area on the Main Chassis. Ensure the membrane is flat with no ripples or folds. Press down firmly, applying 2-3 lbs. of force.

### 8.8.1.5 Servicing Chassis Ground Contact:

**NOTE:** Chassis Ground Contact (6) will be damaged during disassembly.

1. Complete steps from [Section 8.7.1.](#) through [Section 8.7.9.](#) of [Section "8.7 Radio Disassembly" on page 1:8-12.](#)
2. Slide the Black Stick under the Chassis Ground Contact (6) through the opening on the RF/VOCON PCB side of the radio to lift off the contact.
3. Clean the area once the Chassis Ground Contact is removed to ensure it is free of adhesive and debris.
4. Remove the backer of the Chassis Ground Contact and place it in the appropriate location with a pair of flat tip tweezers by aligning the hole in the Ground Contact with the post located on the chassis. Ensure the Ground Contact is centered in the opening and the outer surface of the Ground Contact is parallel to the area adjacent to it in the chassis as shown in [Figure 8-29.](#)
5. Apply pressure to the adhesive to activate it.

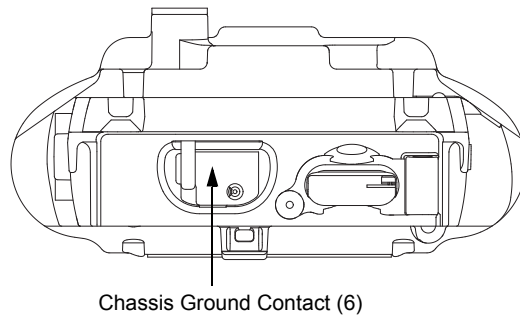

Figure 8-29. Remove Chassis Ground Contact

**NOTE:** There are no other serviceable components on the Main Chassis Assembly (K).

## 8.8.2 Servicing Control Top Assembly (J)

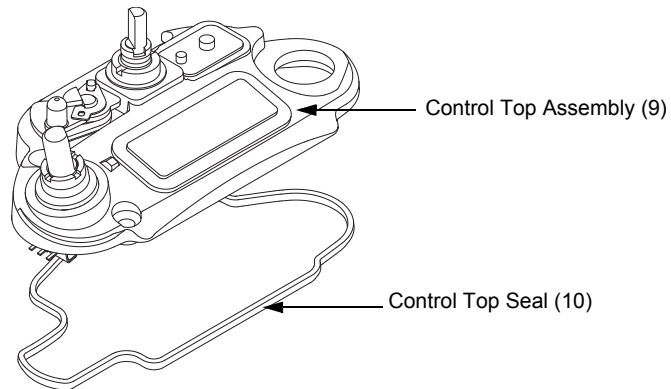

Figure 8-30. Control Top Assembly and Control Top Seal

### 8.8.2.1 Control Top Main Seal

1. Complete steps from [Section 8.7.1.](#) through [Section 8.7.9.](#) of [Section "8.7 Radio Disassembly" on page 1:8-12.](#)
2. Remove the Control Top Seal (10) with the Black Stick.
3. Replace the new seal into the groove provided in the Control Top Assembly's casting.
4. Ensure that seal is set properly and not stretched.

**NOTE:** There are no other serviceable components on the Control Top Assembly (J).



### 8.8.3 Servicing Knobs and Top Bezel Assembly (H)

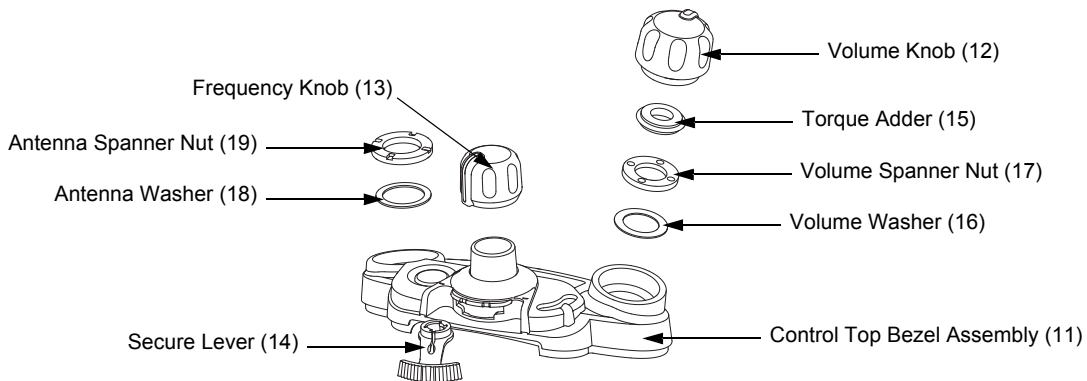

Figure 8-31. Top Bezel Assembly

#### 8.8.3.1 Secure Lever

1. Complete steps from [Section 8.7.8.](#) of [Section "8.7 Radio Disassembly"](#) on page 1:8-12.
2. Pull the Secure Lever (14) straight out of Control Top Bezel Assembly (11) as shown in [Figure 8-31.](#)
3. Insert the lever's arm into the bezel's slot.

**NOTE:** All serviceable components on the Top Bezel Assembly are shown in [Figure 8-31.](#)

### 8.8.4 Servicing VOCON Board Assembly (G, O)

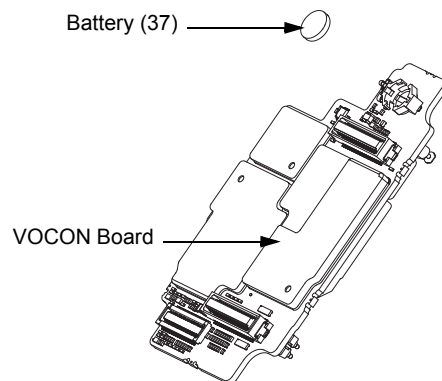

Figure 8-32. VOCON Board Assembly

#### 8.8.4.1 Back up Battery

1. Complete steps from [Section 8.7.1.](#) through [Section 8.7.7.](#) of [Section "8.7 Radio Disassembly"](#) on page 1:8-12.
2. Remove the battery with the Black Stick.

**NOTE:** Make sure the positive side is facing upwards.

3. Press the new battery into the battery carrier until it is secured and fully snapped into place.

**NOTE:** There are no other serviceable components on the VOCON Board Assembly.

## 8.8.5 Servicing of RF Board Assembly

Complete steps 8.7.1 through 8.7.6 of Section "8.7 Radio Disassembly" on page 1:8-12.

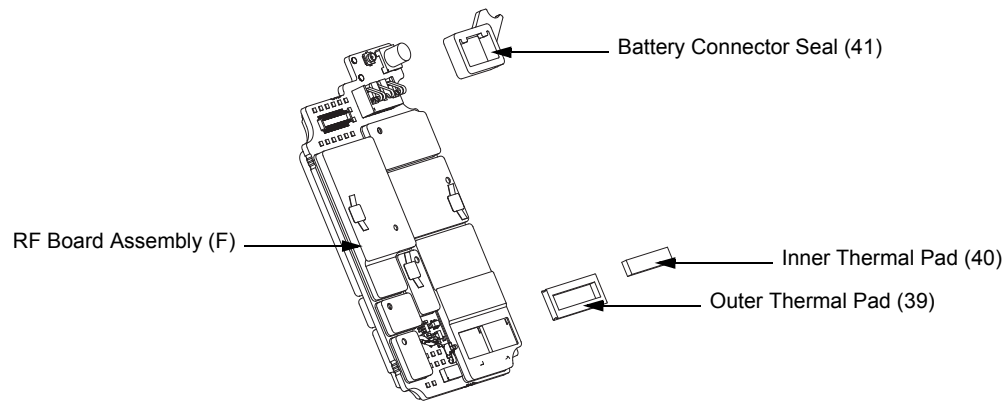

Figure 8-33. RF Board Assembly

### 8.8.5.1 Battery Seal

1. Slide the Battery Connector Seal (41) from the battery contact header with the Black Stick.
2. Use the Black Stick and push the new Battery Connector Seal until it is properly seated onto the RF Board surface.

### 8.8.5.2 Thermal Pads

1. Scrape off both thermal pads (39 and 40) from the amplifiers and / or Main chassis with the Black Stick.
2. Ensure there are no debris or residue left on the amplifier's surfaces.
3. Replace with new thermal pads.
4. Peel off the back liner from the thermal pads.
5. Insert the Outer Thermal Pad (39) into the shield opening. Make sure the bottom surface of the pad is mating with the top surface of the amplifiers.
6. Insert the Inner Thermal Pad (40) without compressing or deforming it.

**NOTE:** There are no other serviceable components on the RF Board Assembly.



Caution

Thermal pads should always be replaced when RF Board assembly is removed.

## 8.8.6 Servicing of Expansion Board Assembly

1. Complete steps 8.7.1 through 8.7.3 of [Section “8.7 Radio Disassembly”](#) on page 1:8-12.

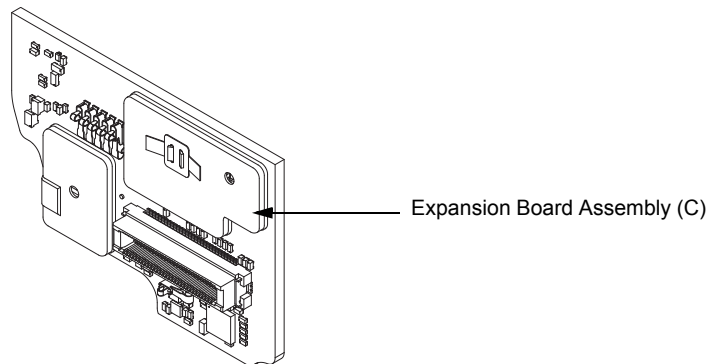

Figure 8-34. Expansion Board Assembly

**NOTE:** There are no serviceable components on the Expansion Board Assembly.

## 8.8.7 Servicing Back Chassis Assembly (E) – Dual Display Version

1. Complete steps 8.7.1 through 8.7.5 of [Section “8.7 Radio Disassembly”](#) on page 1:8-12.

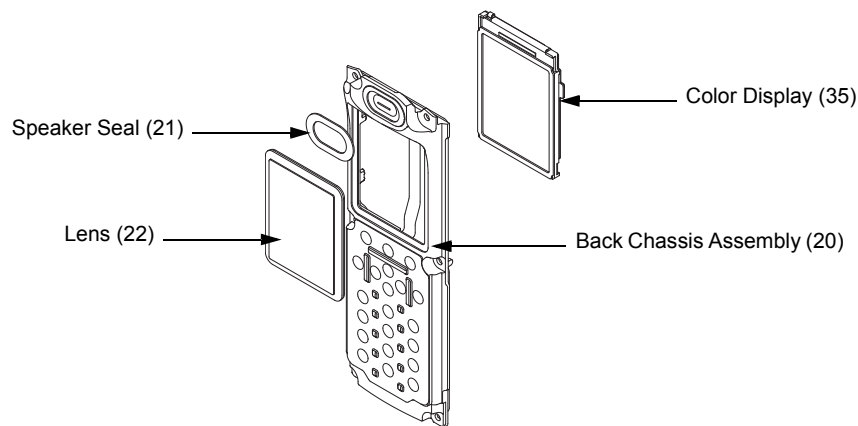

Figure 8-35. Back Chassis Assembly (Dual Display Version)

**NOTE:** Take care not to damage the Color Display during disassembly.

### 8.8.7.1 Servicing Color Display

1. Disconnect the Back Chassis Flex from the back of the Color Display (35).
2. Gently pry the Color Display out of the Back Chassis Assembly (20) by using the Black Stick against the white section of the frame (upper left corner at the back of the Color Display).



Caution

Take care not to damage the Back Chassis seal while servicing the Back Chassis.

3. Remove any remnants of the Display's Pad if it does not come off completely with the Color Display from the back Chassis Assembly.

4. Clean the area to ensure it is free of adhesive and debris once the Display is completely removed.
5. Ensure there are no foreign material on the new Color Display or the Lens (22).
6. Remove the liner from the new Color Display and seat it into the Back Chassis Assembly.
7. Ensure the Display is oriented correctly and seated properly.

### 8.8.7.2 Servicing the main Lens

**NOTE:** Prior to Lens removal, Color Display must be removed (See [Section 8.8.7.1 on page 1:8-25](#)).

1. Remove the main Lens (22) carefully and slowly with the Black Stick.

**NOTE:** To ease the breaking of the adhesive bond, place Back Chassis in freezer.

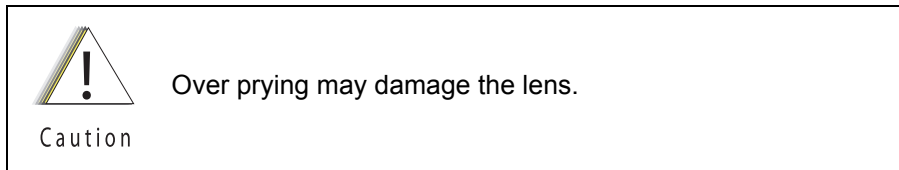

2. Clean the area once the Lens is completely removed to ensure it is free of adhesive and debris.
3. Peel the liner off of the adhesive side of the new Lens and place it centered left to right in the lens pocket of the back Chassis assembly. Bias it upwards against the horizontal surface.
4. Press the Lens down.
5. Ensure the adhesive shows no sign of air entrapments.

### 8.8.7.3 Servicing the Speaker Seal

**NOTE:** Speaker Seal (21) will be damaged during disassembly. Do not reuse.

1. Carefully scrape off the Speaker Seal (21) with the Black Stick without contacting the Speaker.
2. Clean the area once the Speaker Seal is completely removed, to ensure it is free of adhesive and debris.
3. Replace with a new Speaker Seal.
4. Peel the liner off and place the new Seal centered to the speaker and press onto the Back Chassis.

**NOTE:** There are no other serviceable components on the Back Chassis Assembly.

### 8.8.8 Servicing Back Chassis Assembly (M) – Top Display Version

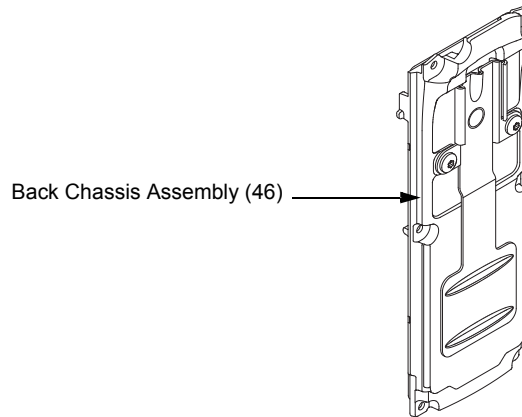

Figure 8-36. Back Chassis Assembly (Top Display Version)

**NOTE:** There are No serviceable Components on the Back Chassis Assembly.

### 8.8.9 Servicing Main Housing (D) – Dual Display Version

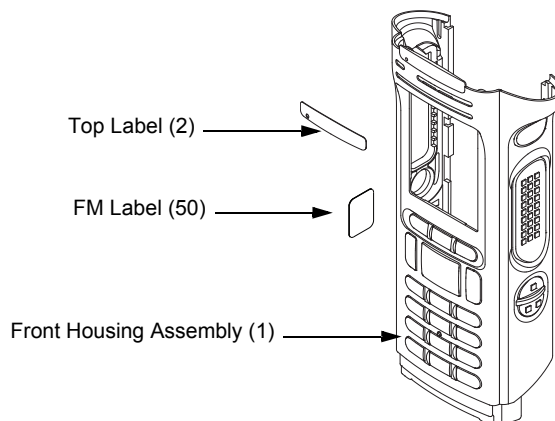

Figure 8-37. Main Housing Assembly (Dual Display Version)

#### 8.8.9.1 Top Label

**NOTE:** There is no need to remove any components in order to service the Top Label (2).

1. Scrape off the Top Label (2) with the Black Stick.
2. Clean the area once the Top Label is completely removed to ensure it is free of adhesive and debris.
3. Replace with a new Label.
4. Remove the liner and place the label in the recess.
5. Press the label.

### 8.8.9.2 FM Label (50)

**NOTE:** There is no need to remove any components in order to service the FM Label (50).

1. Scrape off the FM Label (50) with the Black Stick.
2. Clean the area once the FM Label is completely removed to ensure it is free of adhesive and debris.
3. Replace with a new FM Label.
4. Remove the liner and place the label in the recess.
5. Press the new label.

**NOTE:** There are No Other serviceable components on the Main Housing Assembly (D).

### 8.8.10 Servicing Main Housing (L) – Top Display Version

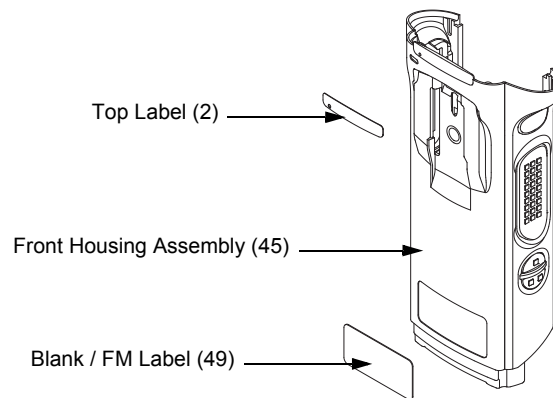

*Figure 8-38. Main Housing Assembly (Top Display Version)*

#### 8.8.10.1 Top Label

**NOTE:** There is no need to remove any components in order to service the Top Label (2).

1. Scrape off the Top Label (2) with the Black Stick.
2. Clean the area once the Top Label is completely removed to ensure it is free of adhesive and debris.
3. Replace with a new Label.
4. Remove the liner and place the label in the recess.
5. Press the label.

#### 8.8.10.2 Blank / FM Label (49)

**NOTE:** There is no need to remove any components in order to service the bottom Label (49).

1. Scrape off the bottom Label (49) with the Black Stick.
2. Clean the area once the bottom Label is completely removed to ensure it is free of adhesive and debris.
3. Replace with a new Label.

4. Remove the liner and place the label in the recess.
5. Press the label.

**NOTE:** There are No Other serviceable components on the Main Housing Assembly (L).

### 8.8.11 Servicing Speaker Module (B)

1. Complete steps 8.7.1 through 8.7.2 of [Section “8.7 Radio Disassembly”](#) on page 1:8-12.

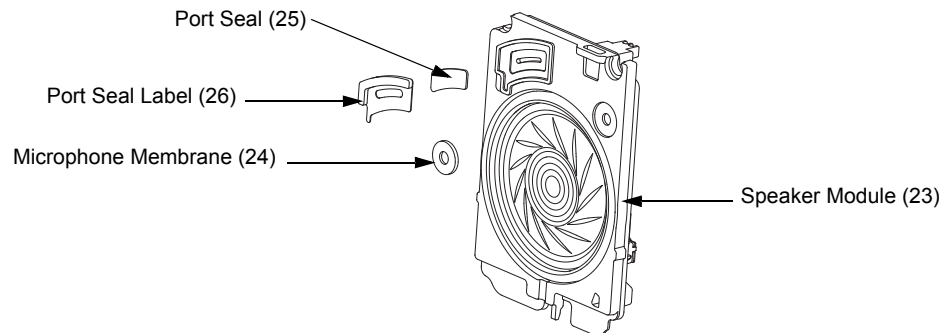

*Figure 8-39. Speaker Module*

#### 8.8.11.1 Servicing Port Seal and Port Seal Label

**NOTE:** Port Seal (25) and Port Seal Label (26) will be damaged during disassembly.

2. Remove the white Port Seal (25) and the black Port Seal Label (26) with the Black Stick.
3. Lift up the Port Seal Label carefully. Do not scratch the mating surface on the Speaker Module (23).
4. Clean the area once both Seals are removed to ensure it is free of adhesive and debris.
5. Remove the backer of the white Port Seal and place it in the appropriate location on the Speaker Module with a pair of flat tip tweezers. Ensure the seal is flat with no ripples, folds or tears.
6. Remove the backer of the black Port Seal Label and place it in the appropriate location on the Speaker Module with a pair of flat tip tweezers. Ensure the label is flat with no ripples or folds.

#### 8.8.11.2 Servicing Microphone Membrane

**NOTE:** Disassembly the Microphone Membrane will damage it.

1. Carefully peel off the Microphone Membrane (24) from the Speaker Module (23).
2. Clean the area once the Microphone Membrane is removed to ensure it is free of adhesive or debris. Ensure nothing comes in contact with the microphone while cleaning.
3. Remove the backer from the Microphone Membrane.
4. Carefully place the Microphone Membrane within the recess area on the Speaker Module. Ensure the membrane is flat with no ripples or folds.
5. Press down firmly, applying 2-3 lbs. of force.

**NOTE:** There are No Other serviceable components on the Speaker Module (B).

## 8.8.12 Servicing Speaker Grille Assembly (A)

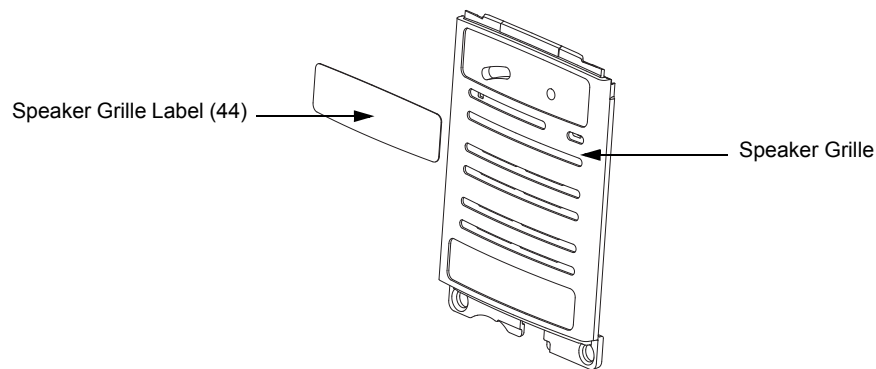

Figure 8-40. Speaker Grille Assembly

**NOTE:** Grille Label will be damaged during disassembly.

### 8.8.12.1 Servicing Grille Label

**NOTE:** There is no need to remove any components in order to service the Speaker Grille Label (44).

**NOTE:** Grille Label will be damaged during disassembly.

1. Remove the Grille Label by using the Black Stick to lift it. Be careful not to damage the Speaker Grille Assembly's (27) surface.
2. Clean the area once the Grille Label is removed to ensure it is free of adhesive and debris.
3. Remove the backer of the new Grille Label and place in the appropriate location using a flat tip tweezer.

**NOTE:** There are No Other serviceable components on the Speaker Grille Assembly (A).



## 8.9 Radio Reassembly

This section contains instructions for reassembling the radio.

### 8.9.1 Reassemble the Main Sub Assemblies

#### 8.9.1.1 Assemble Control Top Assembly (J) to Main Chassis Assembly (K)

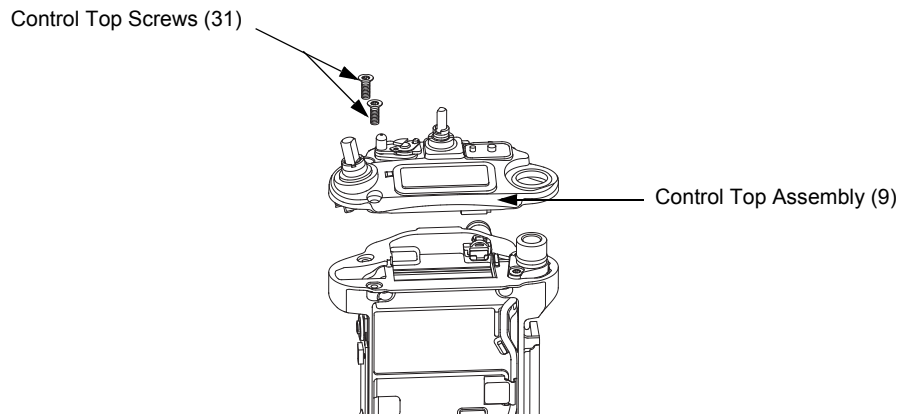

*Figure 8-41. Control Top Bezel Assembly*

1. Verify there are no surface irregularities such as scratches or indentations on both the Control Top Seal Groove and the Seal's mating surface on the Main Chassis Assembly (3). Also ensure that the Control Top Seal (10) and surrounding surfaces are free of debris and other foreign material.
2. Verify Control Top Seal is properly seated into its groove and place Control Top Assembly onto Main Chassis Assembly as shown in [Figure 8-41](#).
3. Torque both screws with a Torx IP8 Bit and a torque Driver to 8 in-lbs.

#### 8.9.1.2 Assemble Knobs and Top Bezel Assembly (H)

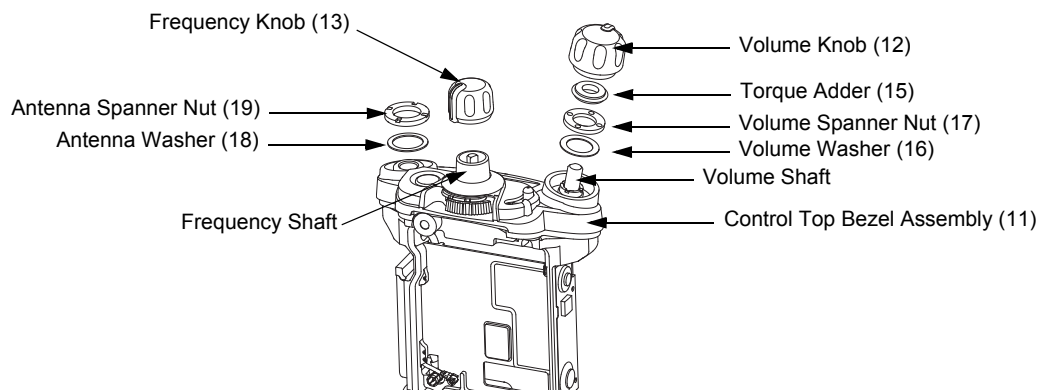

*Figure 8-42. Top Bezel Assembly*

1. With the Secure Lever (14) in place, slide the Control Top Bezel onto the Control Top. Ensure that the Secure Lever is keyed correctly on the Frequency outer shaft. Use the Secure Lever Setter to fully set the lever into place.

2. While holding down the bezel, place the Volume Washer (16) onto the Volume Shaft. See [Figure 8-42](#).
3. Tighten the Volume Spanner Nut (17) by hand first to avoid cross threading. Then, torque the nut with the Volume Spanner Bit at 8 in-lbs.
4. Place the Antenna washer (18) onto the antenna threaded hub as shown in [Figure 8-42](#).
5. Tighten the Antenna Spanner Nut (19) by hand first to avoid cross threading. Then, torque the nut with the Antenna Spanner Bit at 16 in-lbs.
6. Slide and ensure the Torque Adder (15) is fully seated onto the Volume Potentiometer's Hub.
7. Align the D-shaped part of the Volume Shaft with the D-shape hole in the Volume Knob (12) and press the Volume Knob into place.
8. Align the D-shaped part of the Frequency Shaft with the D-shape hole in the Frequency Knob (13) and press the Frequency Knob into place.

### 8.9.1.3 Assemble VOCON Board Assembly (G, O)

1. Inspect the Main Chassis (3) sealing surfaces to make sure there is no surface irregularities such as scratches or indentations. Clean any debris or other foreign material.
2. Inspect the two thermal pads (8) on the front and back of the unit along with the Coin Cell Pad (7) to confirm pads are clean and free of debris as shown in [Figure 8-43](#).

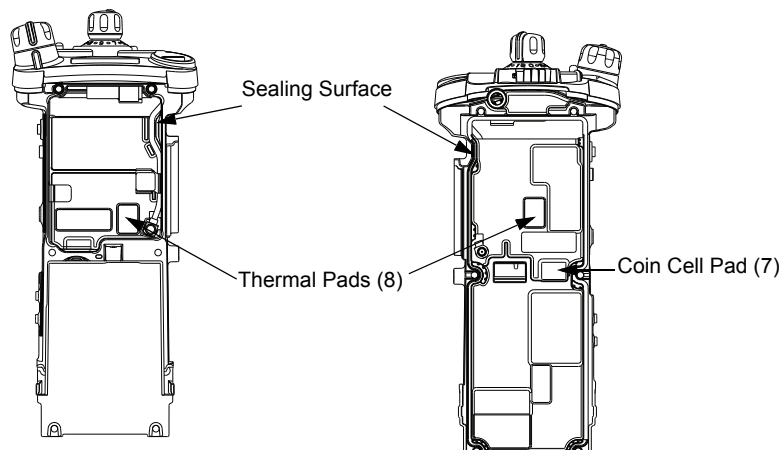

Figure 8-43. Inspect Pads

3. Orient the Main Chassis (3) with the Frequency Knob (13) on top. Insert the VOCON Board Assembly (36) into the chassis starting at a 45° angle and rotate the board into place. Ensure the control top flex is located below the PCB, and is not being pinched between the PCB and the casting. See [Figure 8-44](#).

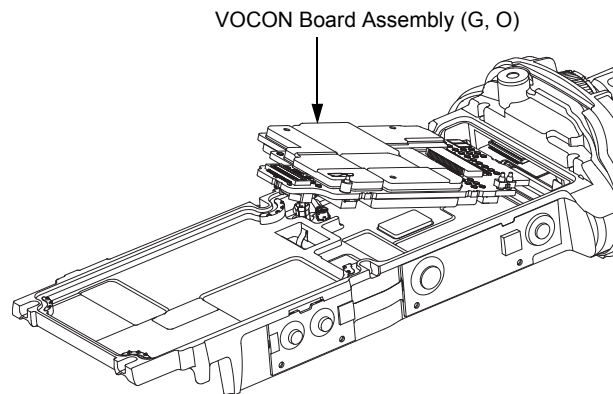

Figure 8-44. Insert VOCON Board

#### 8.9.1.4 Assemble RF Board Assembly (F)



Caution

Always replace with new thermal pads. See [Section "8.8.5.2 Thermal Pads"](#) on page 1:8-24.

1. Inspect the Battery Connector Seal (41) on the RF Board Assembly (F) for any damage or debris. Replace seal if necessary.
2. Connect the small coaxial cable connector into the RF Board (38).
3. Connect the RF Board (38) to the VOCON Board as shown in [Figure 8-45](#).

**NOTE:** Do not connect the Antenna coax at this time. Front Housing Assembly (1) must be snapped in place prior to connecting the coax.

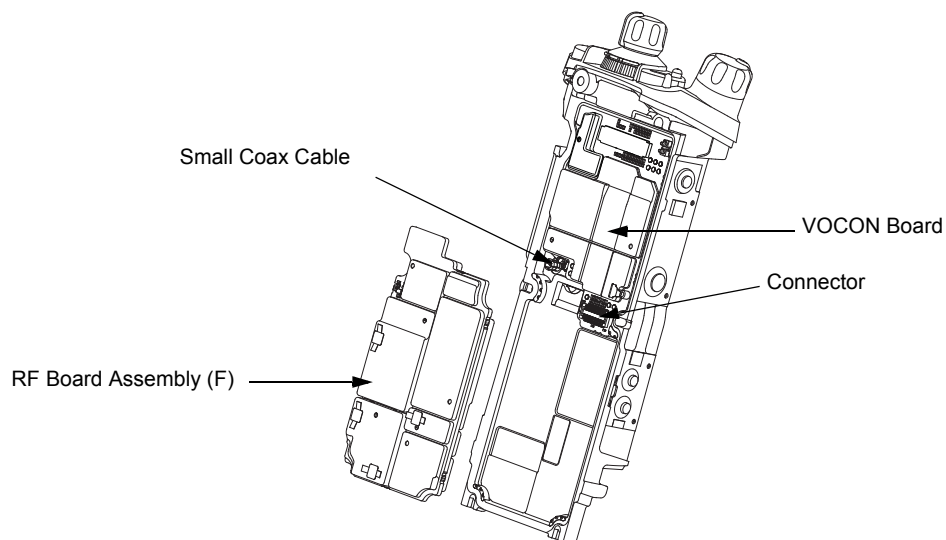

Figure 8-45. Connect RF Board to VOCON Board

### 8.9.1.5 Assemble Back Chassis Assembly (E, M)

#### Dual Display version:

1. Inspect the Back Chassis Assembly seal for any debris or foreign material.
2. Connect the Back Chassis Flex to the VOCON board (G).
3. Set the Back Chassis Assembly (E) onto the Main Chassis Assembly (K).

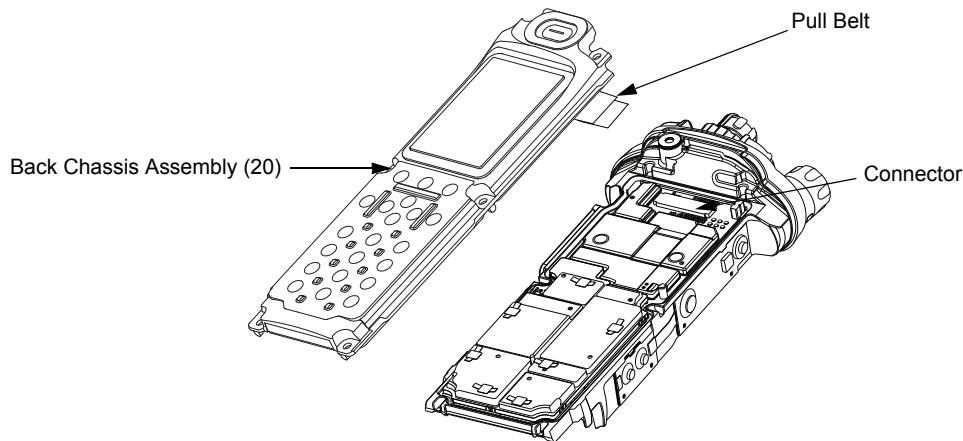

Figure 8-46. Place Back Chassis

#### Top Display version:

1. Inspect the Back Chassis Assembly (M) seal for any debris or foreign material.
2. Set the Back Chassis Assembly (M) onto the Main Chassis Assembly (K).

### 8.9.1.6 Assemble Main Housing Assembly (D, L)

1. Stretch the Main Housing Assembly (D,L) side walls outward with both hands just enough to clear the Main Chassis (K) and place it onto the radio.
2. Ensure the top edge of the housing and the bottom edge of the control top are aligned as shown in [Figure 8-47](#).
3. Squeeze the Main Housing Assembly (D,L) and the Main Chassis Assembly (K) in the battery area until the Main Housing Assembly fully snaps in place onto the Main Chassis Assembly.

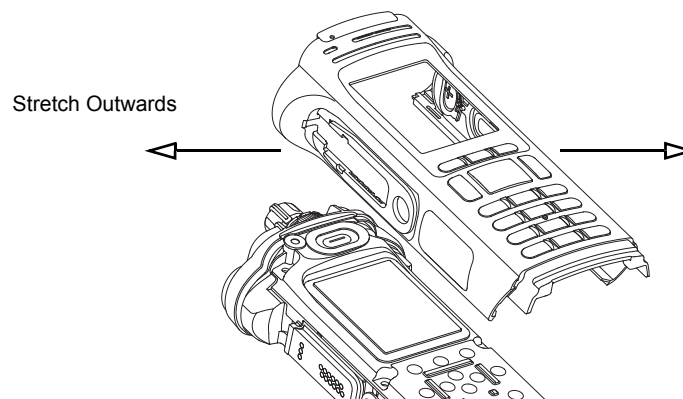
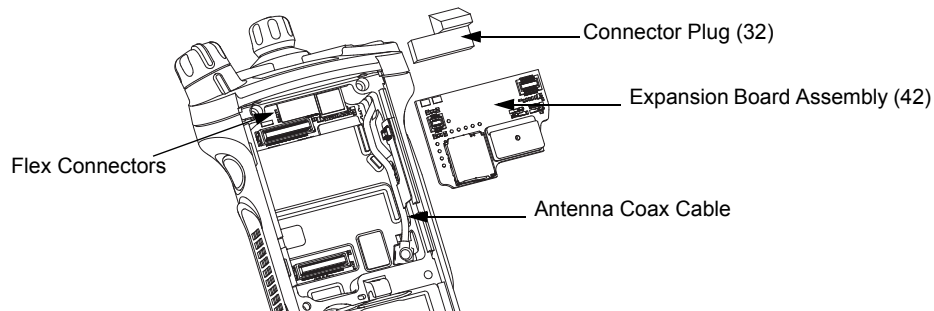

Figure 8-47. Place Housing into Main Chassis

### 8.9.1.7 Assemble Expansion Board Assembly (C)



*Figure 8-48. Assemble Expansion Board Assembly*

1. If the Control Top Assembly (J) or VOCON Board Assembly (G, O) was NOT removed skip to step 2.  
Connect the Control Top Flex to the VOCON Board Assembly as shown in [Figure 8-48](#).
2. If the RF Board Assembly (38) was NOT removed, skip to step 4.  
Carefully align the Antenna Coax Plug to the Coax Receptacle on the RF board Assembly (F) and slide the plug in using the Black Stick. Ensure the universal connector flex is not caught under the antenna coax cable.
3. Tuck in the Antenna Coax Cable into its grooves as shown in [Figure 8-48](#).
4. Plug the Expansion Board Assembly (C) to the VOCON Board Assembly (G, O) as shown in [Figure 8-48](#). Make sure the connector is fully engaged.
5. Connect the two Flex Connectors to their pairing connectors on the right and left sides of the Expansion Board Assembly as shown in [Figure 8-49](#).

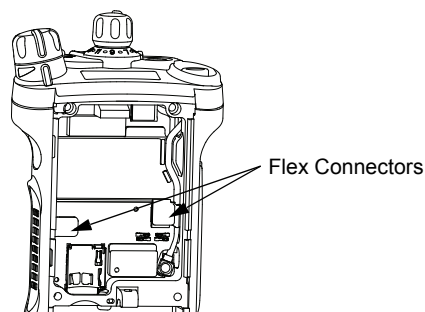

*Figure 8-49. Insert Flex Connectors*

6. If the radio is equipped with an Bluetooth Option Board Assembly skip this step. Install the Connector Plug (32) by inserting it onto the Option Board Connector on the VOCON Board Assembly as shown in [Figure 8-48](#).

### 8.9.1.8 Assemble Bluetooth Option Board Assembly (if so equipped)

1. Connect the Bluetooth Option Board Assembly to the VOCON Board Assembly. Ensure it is completely connected as shown in [Figure 8-50](#).

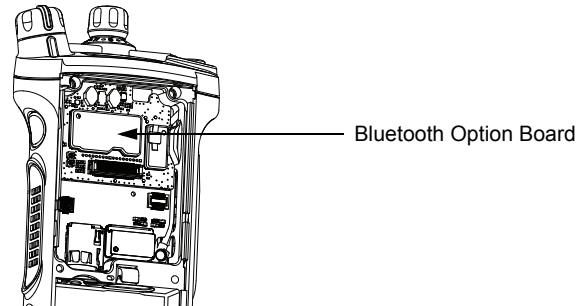

Figure 8-50. Assemble Bluetooth Option Board

2. Rotate the Bluetooth Option Board locking levers till they slide under the chassis feature and lock the option board in place. Levers should be fully rotated until they rest as shown in [Figure 8-51](#).

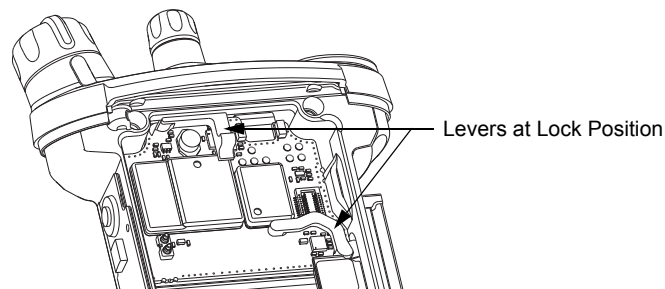

Figure 8-51. Lock Levers

### 8.9.1.9 Assemble Speaker Module (B)



Caution

Do not touch the speaker cone or the Port Seal (25). Take extra precaution to make sure neither the speaker nor the breather pad is damaged.

1. Apply a thin film of Lubricant (Part Number 1110027B23) to the upper two corners of the Main Chassis (3) in the Speaker Module (23) opening as shown in [Figure 8-52](#). Ensure no lubricant contaminates the gold pads or the microphone membrane.

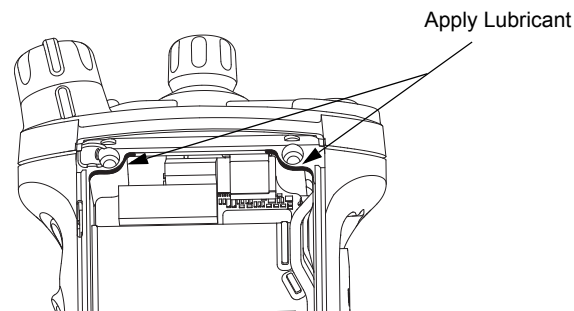
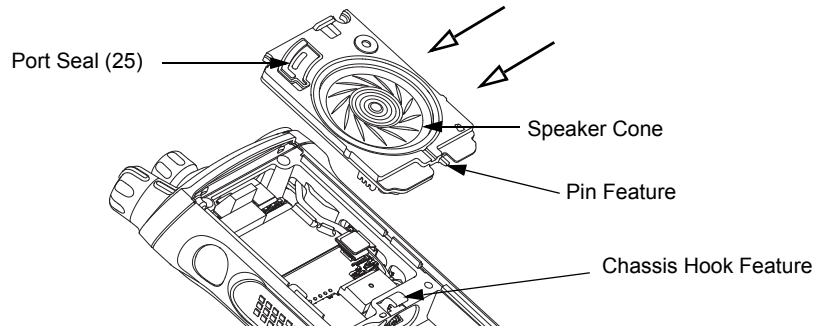

Figure 8-52. Lubricate Main Chassis

**NOTE:** Avoid any lubricant to come in contact with any internal components.

2. Ensure the Seal is free from any debris or foreign material.
3. Align the Speaker Module's Pin feature located on the bottom edge directly below the speaker, into the hole on the chassis hook feature.
4. Swing the Speaker Module down and firmly press the top side into the radio as shown in [Figure 8-53](#).



*Figure 8-53. Insert Speaker Module*

5. While holding the Speaker Module down, place the two top screws (28) into their respective holes and torque the screws to 10 in-lbs with an IP8 Torx Bit in a torque driver. See [Figure 8-54](#).

**IMPORTANT:** For proper sealing, Speaker Module (B) must be held down during the torquing of the screws.

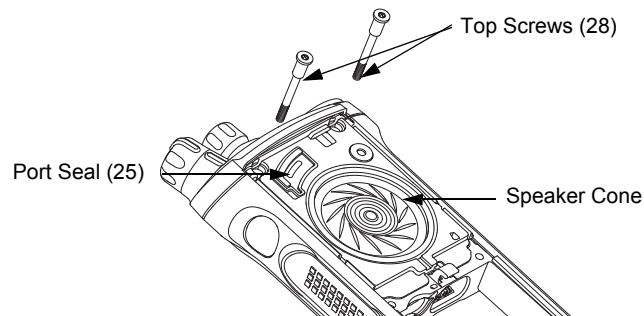

*Figure 8-54. Insert Top Screws*

### 8.9.1.10 Assemble Speaker Grille Assembly (A)

1. Install the Speaker Grille (A) by inserting the top lip under the control top bezel and rotating the grille into place. See [Figure 8-55](#).

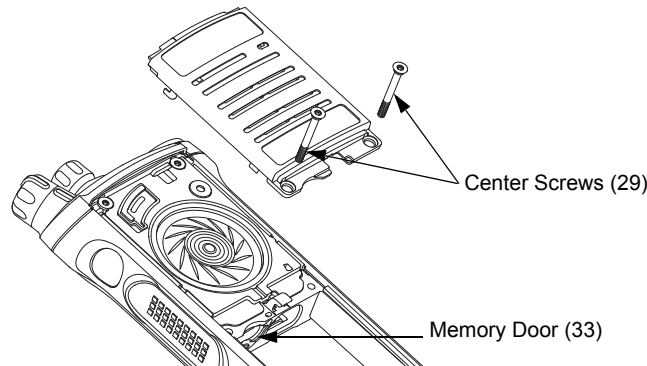

*Figure 8-55. Remove Center Screws*

**NOTE:** Ensure the Memory Door (33) is in place and the memory door screw shaft is aligned with the screw hole.

2. Insert the two center screws (29) and torque to 10 in-lbs. See [Figure 8-56](#).

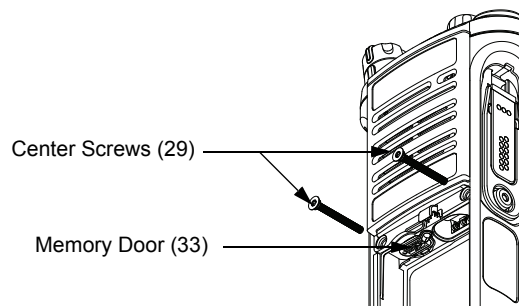

*Figure 8-56. Insert Center Screws*

3. If removed, insert the two bottom screws (30) into the screw holes at the bottom of the radio as shown in [Figure 8-57](#)., and torque to 10 in-lbs.

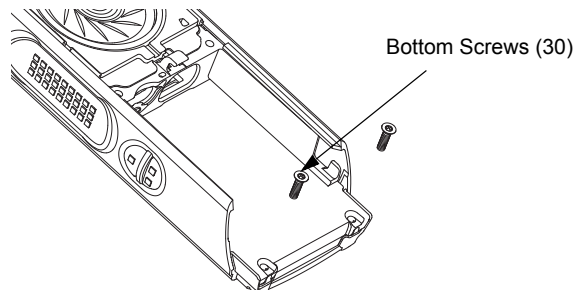

*Figure 8-57. Insert Bottom Screws*

**NOTE:** Refer to the appropriate section in this manual for reinstalling the antenna, battery, or any other accessory that was previously connected or attached to the radio prior to servicing.



## 8.10 Ensuring Radio Submergibility

This section discusses radio submergibility concerns, tests, and disassembly and reassembly of ASTRO APX 7000 R radios.

### 8.10.1 Standards

ASTRO APX 7000 R radio models meet the stringent requirements of U. S. MIL-STD-810C, Method 512.1, Procedure I; MIL-STD-810D, Method 512.2, Procedure I; MIL-STD-810E, Method 512.3, Procedure I; and MIL-STD-810F, Method 512.4, Procedure I, which require the radio to maintain watertight integrity when immersed in six (6) feet of water for two hours.

### 8.10.2 Servicing

APX 7000 R radios shipped from the Motorola Solutions factory have passed vacuum testing and should not be disassembled. If disassembly is necessary, refer to qualified service personnel and service shops capable of restoring the water ight integrity of the radio.



Caution

It is strongly recommended that maintenance of the radio be deferred to qualified service personnel and service shops. This is of paramount importance as irreparable damage to the radio can result from service by unauthorized persons. If disassembly is necessary, unauthorized attempts to repair the radio may void any existing warranties or extended performance agreements with Motorola. It is also recommended that submergibility be checked annually by qualified service personnel.

### 8.10.3 Water Exposure

If the radio is exposed to water, shake the radio to remove the excess water from the speaker grille and microphone ports areas before operating; otherwise, the sound may be distorted until the water has evaporated, or is dislodged from these areas.

### 8.10.4 Specialized Test Equipment

This section summarizes the specialized test equipment necessary for testing the integrity of ASTRO APX 7000 R radios.

To ensure that the radio is truly a watertight unit, special testing, test procedures, and specialized test equipment are required. The special testing involves a vacuum check of the radio and pressure testing (troubleshooting) for water leaks if the vacuum check fails. The specialized test equipment is needed to perform the vacuum check and pressure testing, if required.

#### 8.10.4.1 Vacuum Pump Kit NLN9839\_

The Vacuum Pump Kit includes a Vacuum Pump with gauge and a Vacuum Hose. The Vacuum Adapter (p/n 66009259001) which connects the vacuum pump to the radio, must be ordered separately.

#### 8.10.4.2 Pressure Pump Kit NTN4265\_

The Pressure Pump Kit includes a Pressure Pump with gauge and a Pressure Hose. As with the Vacuum Pump Kit above, the Vacuum Adapter connects the pressure pump to the radio.

### 8.10.5 Disassembly

Disassemble the radio according to [Section "8.7 Radio Disassembly" on page 1:8-12](#).

## 8.10.6 Reassembly

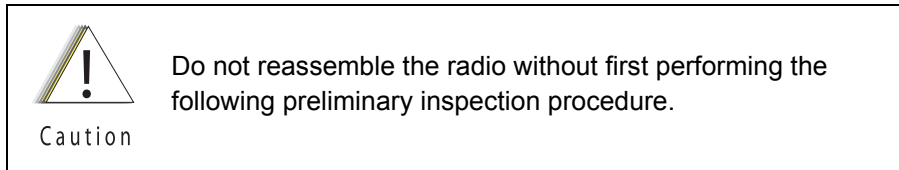

To reassemble the radio:

1. Inspect the seal on the Back Chassis Assembly (E, M) for any damage or foreign material.
2. Inspect the seal on the Speaker Module (B) for any damage or foreign material.
3. Inspect the Battery Connector Seal (41) on the RF Board Assembly (G, O) for any damage.
4. Inspect the mating seal surfaces on the Main Chassis (3) for all of the above seals for damage or foreign material that might prevent the seals from sealing properly.

Continue reassembling the radio according to [Section "8.9 Radio Reassembly" on page 1:8-31](#). Tighten all hardware that was loosened or removed.

## 8.10.7 Vacuum Test

The Vacuum Test uses a Vacuum Pump to create a negative pressure condition inside the radio. The gauge measures this pressure and is used to monitor any pressure changes in the radio. A properly sealed, watertight radio should have minimal change in pressure during the test.

Before starting the vacuum test:

- Remove the battery and antenna.
- Remove the Universal Connector Cover (43) or any other accessories to expose the universal connector.

**NOTE:** Refer to the exploded view diagrams and parts lists found in ["Chapter 10. Exploded Views and Parts Lists" on page 1:10-1](#).

### 8.10.7.1 Vacuum Tool Setup

1. Attach one end of the hose to the Vacuum Pump. Attach the other side of the hose to the Vacuum Adapter.
2. Tool Leak Test:
  - i. Block the open end of the Vacuum Adapter.
  - ii. Pull the knob on the Vacuum Pump to create vacuum.
  - iii. Pump at least 15 inHg.
  - iv. Watch the gauge for a minute. If there is any loss of vacuum, repair or replace the tool.
3. Ensure that the seal is attached to the Vacuum Adapter.

### 8.10.7.2 Attaching Grille Eliminator

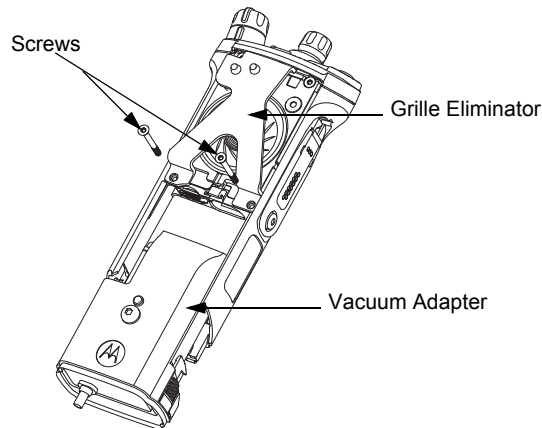

Figure 8-58. Attaching Grille Eliminator

1. Remove the Speaker Grille (27) by following steps in [Section 8.7.1 on page 1:8-12](#) and remove the Memory Door (33).
2. Slide the top of the Grille Eliminator under the Control Top Bezel (11) and swing it down towards the radio. Secure the Grille Eliminator using the two center screws (29) with a torque of 10 in lbs. See [Figure 8-58](#).

### 8.10.7.3 Test Procedure

1. Attach the Vacuum Adapter onto the radio in the same manner as a radio battery. Ensure both latches are clicked into place.
2. Place the radio on a flat surface with the Grille Eliminator facing upward.
3. Pull the knob on the Vacuum Pump to create vacuum. The vacuum test pressure should be between 5-7 inHg.



Caution

Ensure that the vacuum pressure NEVER exceeds 7 inHg. The radio has pressure sensitive components that can be damaged if the pressure exceeds this limit.

4. Observe the gauge for approximately 2 minutes.
  - If the needle falls less than 2 inHg, the radio passes the vacuum test.
    - i. Remove the Grille Eliminator
    - ii. Visually inspect the Port Seal Label (26) for proper adhesion to the Speaker Module (23). Make sure there are no wrinkles or cuts to the material that would cause a leak. Replace seal if damaged. (See appropriate section for servicing the seals).
    - iii. If the seal passes this inspection, this radio is approved for submergibility. No additional testing is required.
    - iv. Replace the Speaker Grille Assembly (27) and Memory Door (33) as described in the reassembly procedures.

- If the needle falls more than 2 inHg, the radio fails the vacuum test and the radio might leak if submerged. Additional troubleshooting of the radio is required.
  - i. Keep the Grille Eliminator and Vacuum Adapter on but remove the Vacuum Pump from the Vacuum Adapter.
  - ii. Goto [Section “8.10.8 Pressure Test \(using NTN4265\\_\)”](#) on page 1:8-42.

### 8.10.8 Pressure Test (using NTN4265\_)

Pressure testing the radio is necessary only if the radio has failed the vacuum test. Do not perform the pressure test until the vacuum test has been completed. Pressure testing involves creating a positive pressure condition inside the radio, submerging the radio in water, and observing the radio for a stream of bubbles (leak). Since all areas of the radio are being checked, observe the entire unit carefully for the possibility of multiple leaks before completing this test.

**NOTES:**When Radio is placed under the water there will be some air trapped which will be released. This is not a failure.

Refer to the exploded view diagrams and parts lists found in [“Chapter 10. Exploded Views and Parts Lists”](#) on page 1:10-1.

The Grille Eliminator must be used to conduct the pressure test:  
If the radio is still set up from vacuum test, skip steps 1 through 4.

To conduct the pressure test:

1. Remove the Speaker Grille (27) by following the steps from [Section “8.7.1 Removal of the Speaker Grille Assemblies \(A\)”](#) on page 1:8-12 and remove the Memory Door (33).
2. Slide the top of the Grille Eliminator under the Control Top Bezel (11) and swing it down towards the radio. Secure the Grille Eliminator using the two center screws (29) with a torque of 10 in lbs. See [Figure 8-58](#).
3. Ensure that an seal is attached to the Vacuum Adapter.
4. Attach the Vacuum Adapter onto the radio in the same manner as a radio battery. Ensure both the latches are clicked into place.
5. Attach one end of the hose to the Pressure Pump. Attach the other side of the hose to the Vacuum Adapter.
6. Operate the pump until the gauge reads approximately 1 psig.



Caution

Pressure must remain between 0.5 psig and 1.5 psig. Pressure lower than 0.5 psig may allow water into the radio, which will damage the radio.



Caution

Ensure that the pressure NEVER exceeds 1.5 psig. The radio has pressure sensitive components that can be damaged if the pressure exceeds this limit.

7. Maintain the pressure around 1 psig and submerge the radio into a water-filled container.

8. Watch for any continuous series of bubbles. A steady stream of bubbles indicates a sign of leakage.

**NOTE:** Some accumulation of air may be entrapped in the main housing which may cause a false diagnosis of a leak. Ensure there is a steady stream of bubbles before concluding there is a leak.

9. Note all of the seal areas that show signs of leakage. Rotate the radio to view all sides to pinpoint the problem(s) to one (or more) of the following areas:
  - Seal Interfaces
  - Speaker Assembly
  - Battery Connector Seal
  - Main Chassis, including the Control Top
  - Back Chassis
10. Remove the radio from the water container and dry the radio thoroughly. Be especially careful to dry the area around the Memory Door (33).

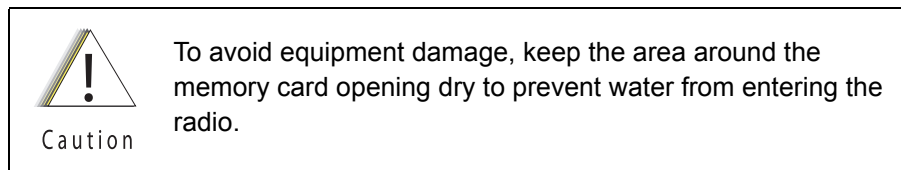

11. With the Radio in an upright position and Control Top up, remove the vacuum adapter by squeezing the release latches, and pulling the adapter down and away from the radio.
12. Ensure the area around the Memory Door (33) opening is dry
13. Dry the remainder of the radio and remove the Grille Eliminator.
14. See [“8.10.9. Troubleshooting Leak Areas”](#) on page 1:8-43.

### 8.10.9 Troubleshooting Leak Areas

Before repairing any leak, first read all of the steps within the applicable section. This will help to eliminate unnecessary disassembly and reassembly of a radio with multiple leaks. Troubleshoot only the faulty seal areas listed in [“8.10.8. Pressure Test \(using NTN4265\\_\)”](#) on page 1:8-42 and, when multiple leaks exist, in the order listed.

**NOTES:**All disassembly and reassembly methods can be found in [Section 8.7.](#) and [Section 8.9.](#)

If in the field, water is found around the battery leads, the O-ring on the Battery should be inspected and replaced if needed.

#### 8.10.9.1 Seal Interfaces

- If leak occurs at one or more of the seal interfaces, disassembly of the component(s) and inspection of the interfaces to determine if there is any damage. If no damage is observed, re-assemble the radio as directed.
- If damage has occurred, replacement parts will be needed.

#### 8.10.9.2 Speaker Module

- If leak occurs through the Microphone Membrane (24) or the Port Seal (25), replace these items.
- If leak occurs elsewhere on the Speaker Module (B), the module will need to be replaced.

### 8.10.9.3 Battery Contact Seal

- If leak occurs due to damage to the Battery Connector Seal (41), it will need to be replaced.

### 8.10.9.4 Back Chassis

- If leak occurs through the Color Display Lens (22), replace it.
- If leak occurs elsewhere on the Back Chassis (E/M), it will need to be replaced.

### 8.10.9.5 Control Top

- If leak occurs through the antenna or the Control Top Seal (10), replace it.
- If leak occurs elsewhere on the Control Top Assembly (J), it will need to be replaced.

### 8.10.9.6 Main Chassis

- If leak occurs on the Back Chassis (E/M), it will need to be replaced.

---

## Chapter 9 Basic Troubleshooting

This section of the manual contains troubleshooting charts and error codes that will help you to isolate a problem. Level one and two troubleshooting will support only radio alignment, programming, battery replacement, and knob replacement, and circuit board replacement.

Component-level service information can be found in the “ASTRO APX 7000/ APX 7000XE Portable Radios Detailed Service Manual,” Motorola publication number 6875961M01.

### 9.1 Power-Up Error Codes

When the radio is turned on (power-up), the radio performs self-tests to determine if its basic electronics and software are in working order. Problems detected during these tests are presented as error codes on the radio’s display. For non-display radios, the problem will be presented at power-up by a single, low-frequency tone. The radio should be sent to the depot if cycling power and reprogramming the code plug do not solve the problem. The presence of an error should prompt the user that a problem exists and that a service technician should be contacted.

Self-test errors are classified as either fatal or non-fatal. Fatal errors will inhibit user operation; non-fatal errors will not. Use [Table 9-1](#) to aid in understanding particular power-up error code displays.

*Table 9-1. Power-Up Error Code Displays*

Error Code	Description	Corrective Action
01/02	FLASH ROM Codeplug Checksum Non-Fatal Error	Reprogram the codeplug
01/12	Security Partition Checksum Non-Fatal Error	Send radio to depot
01/81	Host ROM Checksum Fatal Error	Send radio to depot
01/82	FLASH ROM Codeplug Checksum Fatal Error	Reprogram the codeplug
01/84	External EEPROM Blank (or SLIC failure) Fatal Error	Send radio to depot
01/88	External RAM Fatal Error – <b>Note:</b> Not a checksum failure	Send radio to depot
01/90	General Hardware Failure Fatal Error	Turn the radio off, then on
01/92	Security Partition Checksum Fatal Error	Send radio to depot
01/93	FLASHport Authentication Code Failure	Send radio to depot
01/94	Internal EEPROM Blank Fatal Error.	Send radio to depot
01/98	Internal RAM Fail Fatal Error	Send radio to depot
01/A0	ABACUS Tune Failure Fatal Error	Send radio to depot
01/A2	Tuning Codeplug Checksum Fatal Error	Send radio to depot
02/81	DSP ROM Checksum Fatal Error	Send radio to depot
02/88	DSP RAM Fatal Error – <b>Note:</b> Not a checksum failure	Turn the radio off, then on

Table 9-1. Power-Up Error Code Displays (Continued)

Error Code	Description	Corrective Action
02/90	General DSP Hardware Failure (DSP startup message not received correctly)	Turn the radio off, then on
09/10	Secure Hardware Error	Turn the radio off, then on
09/90	Secure Hardware Fatal Error	Turn the radio off, then on

**Note:** If the corrective action does not fix the failure, send the radio to the depot.

## 9.2 Operational Error Codes

During radio operation, the radio performs dynamic tests to determine if the radio is working properly. Problems detected during these tests are presented as error codes on the radio’s display. The presence of an error code should prompt a user that a problem exists and that a service technician should be contacted. Use Table 9-2 to aid in understanding particular operational error codes.

Table 9-2. Operational Error Code Displays

Error Code	Description	Corrective Action
FAIL 001	Synthesizer Out-of-Lock	1. Reprogram external codeplug 2. Send radio to depot
FAIL 002	Selected Mode/Zone Codeplug Checksum Error	Reprogram external codeplug

## 9.3 Receiver Troubleshooting

Table 9-3 lists the possible causes of, and corrections for, receiver problems.

Table 9-3. Receiver Troubleshooting Chart

Symptom	Possible Cause	Correction or Test (Measurements at Room Temperature)
Radio Dead; Display Does Not Turn On	1. Dead Battery	Replace with charged battery
	2. Blown Fuse	Send radio to depot
	3. On/Off Switch	
	4. Regulators	
Radio Dead; Display Turns On	1. VOCON Board	Send radio to depot
	2. RF Board	
	3. Expander Board	



Table 9-3. Receiver Troubleshooting Chart (Continued)

Symptom	Possible Cause	Correction or Test (Measurements at Room Temperature)
Radio On; Front Display Off	High operating temperature (above 80°C)	Allow radio to return to normal operating temperature.
No Receive Audio, or Receiver Does Not Unmute	Programming	1. Check if transmitted signal matches the receiver configuration (PL, DPL, etc.) 2. Check if radio able to unmute with monitor function enabled
Audio Distorted or Not Loud Enough	Synthesizer Not On Frequency	Check synthesizer frequency by measuring the transmitter frequency; realign if off by more than $\pm 1000$ Hz
RF Sensitivity Poor	1. Synthesizer Not On Frequency	Check synthesizer frequency by measuring the transmitter frequency; realign if off by more than $\pm 1000$ Hz
	2. Antenna Switch/Connector	Send radio to depot
	3. Receiver Front-End Tuning	Check RF front-end tuning for optimum sensitivity using the tuner
Radio Will Not Turn Off	VOCON Board	Send radio to depot

## 9.4 Transmitter Troubleshooting

Table 9-4 lists the possible causes of, and corrections for, transmitter problems.

Table 9-4. Transmitter Troubleshooting Chart

Symptom	Possible Cause	Correction or Test (Measurements Taken at Room Temperature)
No RF Power Out	1. TX Power Level or Frequency	Check TX power level and frequency programming (from tuner)
	2. No Injection To Power Amplifier	Send radio to depot
	3. Antenna Switch/Connector	
No Modulation; Distorted Modulation	1. Programming	Check deviation and compensation settings using the tuner
	2. VOCON Board	Send radio to depot
Bad Microphone Sensitivity	1. Check Deviation and Compensation	Realign if necessary
	2. Microphone	Send radio to depot

Table 9-4. Transmitter Troubleshooting Chart (Continued)

Symptom	Possible Cause	Correction or Test (Measurements Taken at Room Temperature)
No/Low signaling (PL, DPL, MDC)	1. Programming	Check programming
	2. VOCON Board	Send radio to depot
Cannot Set Deviation Balance	RF Board	Send radio to depot

## 9.5 Encryption Troubleshooting

Table 9-5 lists the possible causes of, and corrections for, encryption problems.

Table 9-5. Encryption Troubleshooting Chart

Symptom	Possible Cause	Corrective Action
No "KEYLOAD" on Radio Display When Keyloading Cable is Attached to the Radio Side Connector	1. Defective Keyload Cable	Send radio to depot
	2. Defective Radio	
Keyloader Displays "FAIL"	1. Wrong Keyloader Type	Use correct keyloader type. Refer to Keyloader User Guide for more information
	2. Bad Keyloader	Try another keyloader
	3. Defective Radio	Send radio to depot

## 9.6 Bluetooth Option / Expansion Board Troubleshooting

Table 9-6 lists the possible causes of, and corrections for, Bluetooth Option / Expansion Board problems.

Table 9-6. Bluetooth Option/Expansion Board Troubleshooting Chart

Message Displayed	Possible Cause	Corrective Action
Hardware board absent	Option / Expansion Board is not present on the radio and feature is enabled by a code plug.	Send radio to depot
Hardware board mismatch	When an option / expansion board feature is enabled in code plug, but the board (EB or OB) does not have corresponding capability.	Send radio to depot
Hardware board failed	Displayed if the board Deenumerated, Enumeration timed out, Option board device initialized with a Fatal Error.	Reset the radio. If this persists, send radio to the depot

Table 9-6. Bluetooth Option/Expansion Board Troubleshooting Chart (Continued)

Message Displayed	Possible Cause	Corrective Action
Update failed Please reset	Bluetooth Option / Expansion board firmware update fails.	Reset radio. if this persists, send radio to the depot

## 9.7 Bluetooth Troubleshooting

Table 9-7 lists the possible causes of, and corrections for, bluetooth problems.

Table 9-7. Bluetooth Troubleshooting Chart

Message Displayed	Possible Cause	Corrective Action
Non_Audio dev connect failed / Audio device connect failed	Displayed when the accessory fails to connect after pairing.	Clear all pairing information and try to pair and connect.
Bluetooth pairing failed	Accessory and Radio failed to pair through MPP/ NFC.	Retry pairing accessory with Radio.
Clear all BT devices failed	Radio was unable to clear information of all the accessories that are paired and/or connected.	Reset the radio.
Bluetooth on failed	Bluetooth Option Board is in an unknown state and is unable to process the request for Bluetooth ON.	Reset the radio. If this continues, send radio to the depot.

## Notes

---

## Chapter 10 Exploded Views and Parts Lists

This chapter contains exploded views and associated parts lists for the ASTRO APX 7000 digital portable radios. The following table lists the exploded views for the APX 7000 radio in different configurations:

*Table 10-1. APX 7000 Exploded Views*

<b>View</b>	<b>Page</b>
<a href="#">APX 7000 Dual Display Exploded View</a>	1:10-2
<a href="#">APX 7000 Top Display Exploded View</a>	1:10-4

### 10.1 APX 7000 Dual Display Exploded View

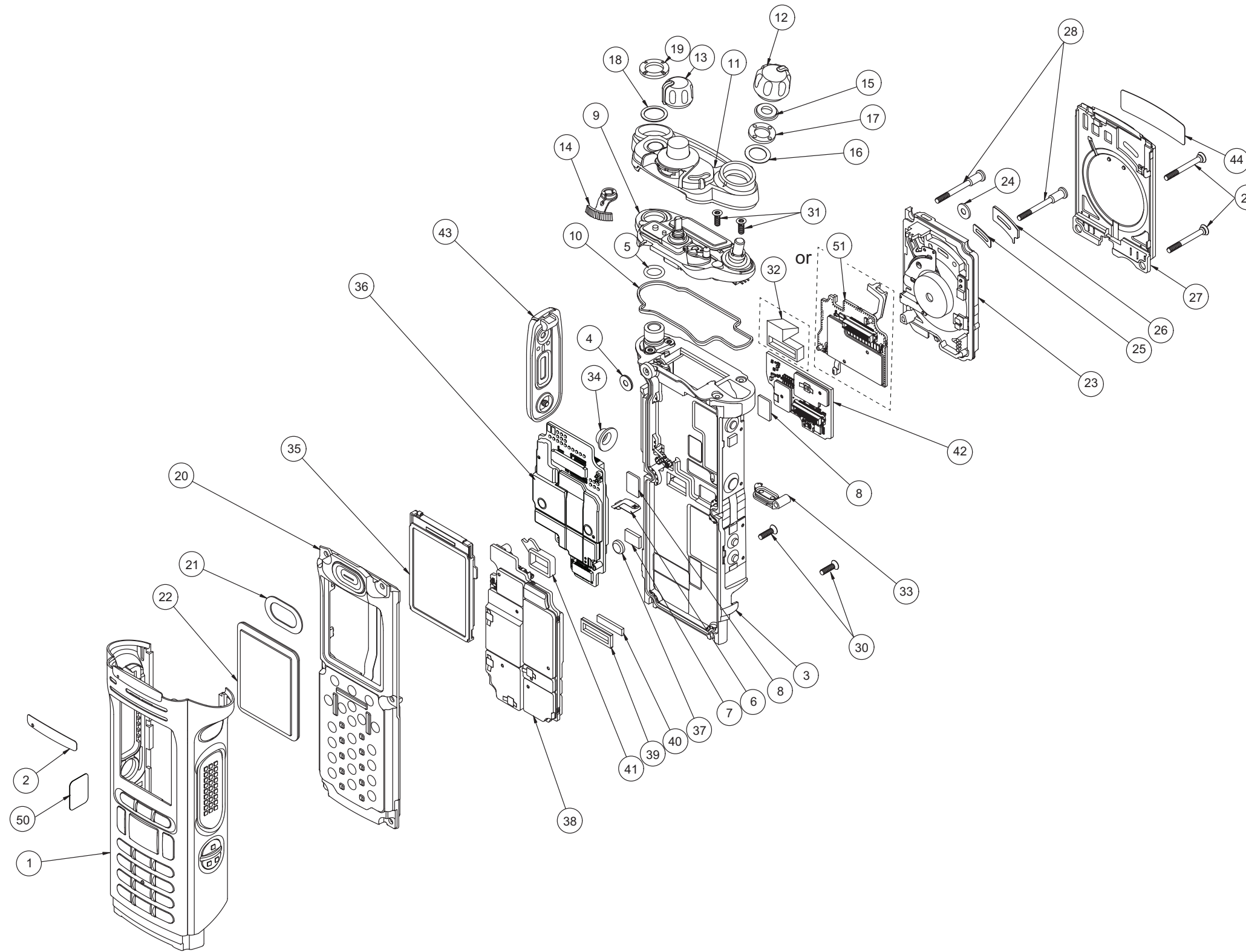

Figure 10-1. APX 7000 Dual Display Exploded View

## 10.2 APX 7000 Dual Display Exploded View Parts List

Item No.	Motorola Part Number	Description
1	NHN7000_01009304007 <sup>1</sup> 01009304008 <sup>1</sup>	Assy, Front Housing, Dual Display (Black) Assy, Front Housing, Dual Display (Yellow) Assy, Front Housing, Dual Display (Green)
2	3375622B01	Label, Housing, Dataside
3	01009304001	Assy, Main, Chassis
4	3275002C02	Seal, Membrane, Microphone
5	3275033C01	O-ring, Antenna, Main
6	3971892H01	Contact, Chassis Ground
7	7505316J16	Pad, Coin Cell Battery
8	7575218H01	Pad (x2), Thermal, Exp & VOCON Board
9	1375044C02 <sup>2</sup>	Assy, Control Top
10	3275031C01	Seal, Control Cap
11	1371891H02	Bezel, Control Top, Subassembly
12	3675581B01	Knob, Volume
13	3675590B03	Knob, Frequency
14	4575585B01	Lever, Secure
15	3275377H01	Seal, Cap, Torque Adder
16	0405659W01	Washer, Wave, Volume
17	0275361H01	Nut, Spanner, Volume
18	0400129O54	Washer, Lock, Antenna
19	0275891B01	Nut, Spanner, Antenna
20	NHN7017_2	Assy, Back Chassis, Dual Display
21	3271816H01	Seal, Speaker, Dataside
22	6175619B02	Lens, Color Display
23	NHN7002_	Module, Speaker

Item No.	Motorola Part Number	Description
24	3275002C02	Seal, Membrane, Microphone
25	3271819H01	Seal, Port
26	5475160H01	Label, Seal, Port
27	01009304004 01009304005 01009304006	Assy, Grille, Speaker (Black) Assy, Grille, Speaker (Yellow) Assy, Grille, Speaker (Green)
28	0375962B01	Screw (x2), M2.5 X 0.45, 30.10 LG
29	0375962B02	Screw (x2), M2.5 X 0.45, 24.45 LG
30	0375962B03	Screw (x2), M2.5 X 0.45, 9.2 LG
31	0375962B04	Screw (x2), M2.5 X 0.45, 7.0 LG
32 <sup>3</sup>	32009064001	Plug, Support, Connector
33	3275882B01	Door, Seal, Memory
34	3875126H01	Cap, Chassis Boss, Universal Connector
35	01009304024 <sup>2</sup>	Display, Color, Back
36	MNCN6202_2.5 MNCN6200_2	Assy, VOCON Board, Dual Display Assy, VOCON Board, Dual Display
37	6003710K08	Battery, Backup, Coincell
38	MNUR4001_ MNUS4000_ MNUT4000_ MNUS4002_ MNUT4004_ MNUE7367_	Assy, Board, RF (VHF / 700-800 MHz) Assy, Board, RF (UHF1 / 700-800 MHz) Assy, Board, RF (UHF1 / VHF) Assy, Board, RF (UHF2 / 7/800 MHz) Assy, Board, RF (UHF2 / VHF) Assy, Board, RF (UHF1 / UHF2)
39	3275623B02	Pad, Thermal, Outer
40	75009299001	Pad, Thermal, Inner
41	3271829H01	Seal, Connector, Battery
42	MHLN6977_ MHLN7035_4	Assy, Board, Expansion Assy, Board, Expansion
43	1575250H01	Cover, Connector, Universal Connector
44	3371896H01 3371896H02	Label, Grille, Speaker for APX 7000 radios Label, Grille, Speaker for APX 7000R radios

Item No.	Motorola Part Number	Description
50	33009274001	Label, Main Housing FM, Dual Displays
51 <sup>3</sup>	NNTN8160_	Assembly, APX Portable Option Board

**NOTE:**

1. HIGH IMPACT GREEN and PUBLIC SAFETY YELLOW Colored Housings can be serviced in the depot and can be ordered via AAD.
2. See [Table 10-2."Compatibility Table" on page 1:10-6.](#)
3. Radios installed with the Option Board Kit NNTN8160\_ do not have the connector plug (32009064001).
4. With TI Chipset.
5. With PCN Display Vocon.

### 10.3 APX 7000 Top Display Exploded View

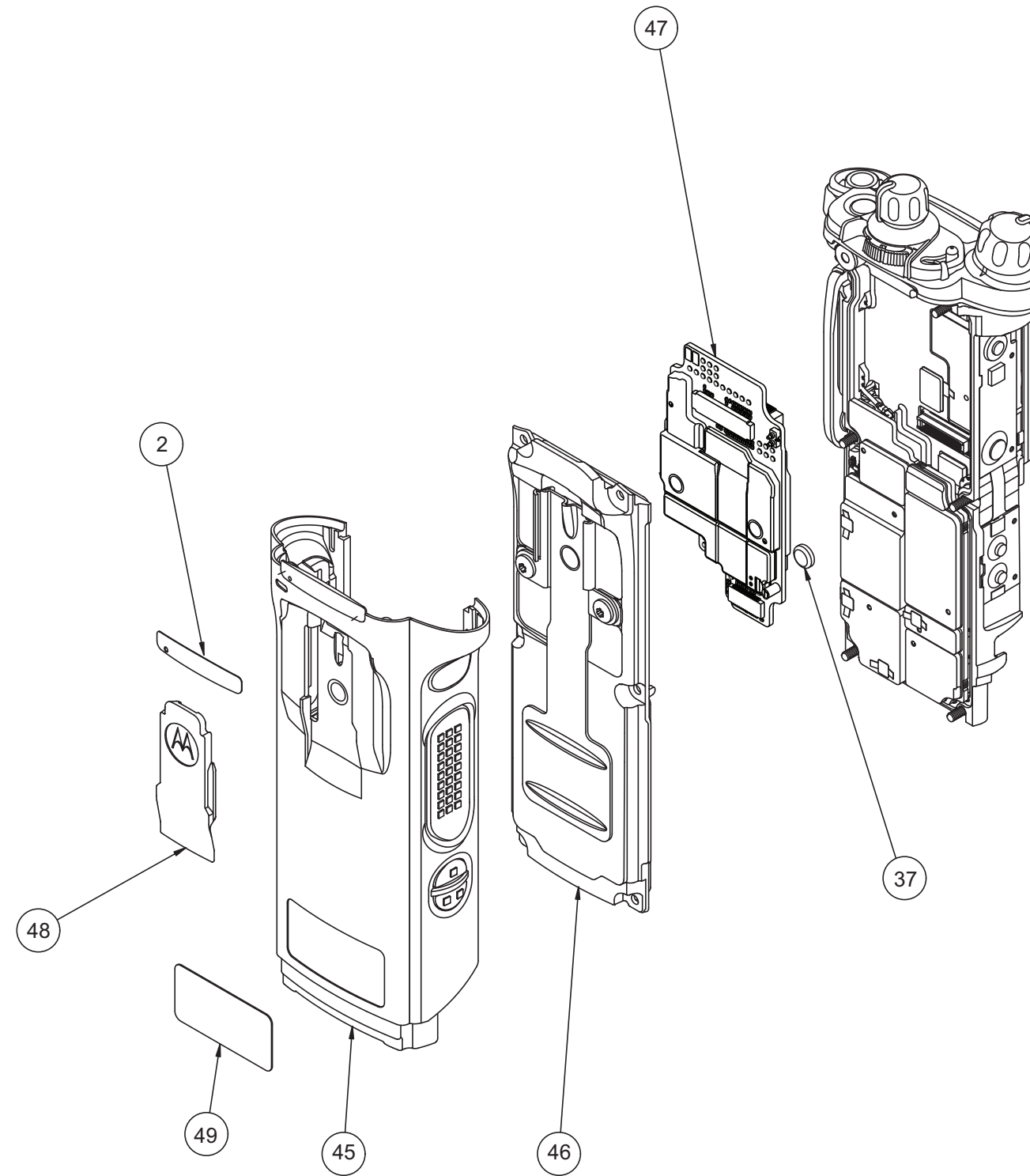

**NOTE:** Refer to Dual Display view for items not exploded.  
Parts shown here are exclusive to Top Display version.

Figure 10-2. APX 7000 Top Display Exploded View



**10.4 APX 7000 Top Display Exploded View Parts List**

Item No.	Motorola Part Number	Description
45	NHN7001_ 01009304009 01009304010	Assy, Front Housing, Top Display (Black) Assy, Front Housing, Top Display (Yellow) Assy, Front Housing, Top Display (Green)
2	3375622B01	Label, Housing, Dataside
46	NHN7004_	Assy, Back Chassis, Top Display
47	MNCN6203_ <sup>2, 5</sup> MNCN6201_ <sup>2</sup>	Assy, VOCON Board Top Display Assy, VOCON Board Top Display
37	6003710K08	Battery, Backup, Coincell
48	1575356H01	Cover, Clip, Belt (See <a href="#">Appendix A"Accessories" on page 3:A-1</a> )
49	3385836D09 3385836D08	Label, Main Housing, Top Display Label, Main Housing FM, Top Display

Table 10-2. Compatibility Table

<b>Compatibility Table</b>	Assy, Control Top – 1375044C02	Assy, Control Top – 1375044C01	Display, Color, Back – 01009304024	Display, Color, Back – 01009304019	Display, Color, Back – 01009304003	Assy, Back Chassis – Dual Display, NHN7017_	Assy, Back Chassis – Dual Display, NHN7003_	VOCON Board, Top – Display MNCN6203_	VOCON Board, Top – Display MNCN6201_	VOCON Board, Dual – Display MNCN6202_	VOCON Board, Dual – Display MNCN6200_
Assy, Control Top – 1375044C02	–	–	●	●	●	●	●	●	●	●	●
Assy, Control Top – 1375044C01	–	–	●	●	●	●	●	●	●	●	●
Display, Color, Back – 01009304024	●	●	–	–	–	●	x	–	–	●	x
Display, Color, Back – 01009304019	●	●	–	–	–	●	x	–	–	●	x
Display, Color, Back – 01009304003	●	●	–	–	–	x	●	–	–	x	●
Assy, Back Chassis – Dual Display, NHN7017_	●	●	●	●	x	–	–	–	–	●	x
Assy, Back Chassis – Dual Display, NHN7003_	●	●	x	x	●	–	–	–	–	x	●
VOCON Board, Top – Display MNCN6203_	●	●	–	–	–	–	–	–	–	–	–
VOCON Board, Top – Display MNCN6201_	●	●	–	–	–	–	–	–	–	–	–
VOCON Board, Dual – Display MNCN6202_	●	●	●	●	x	●	x	–	–	–	–
VOCON Board, Dual – Display MNCN6200_	●	●	x	x	●	x	●	–	–	–	–
<b>Note:</b> ● Compatible x Not Compatible – Not Applicable											

---

# Index

## Numerics

- 700-800 MHz
  - radio specifications 1:xvii
- 700-800 MHz and UHF1
  - model chart 1:xi
- 700-800 MHz and UHF2
  - model chart 1:xiv
- 700-800 MHz and VHF
  - model chart 1:x

## A

- alignment, tuner
  - bit error rate test 1:6-24
  - introduction 1:6-1
  - main menu 1:6-2
  - radio information screen 1:6-4
  - reference oscillator 1:6-4
  - softpot use 1:6-2
  - test setup 1:6-1
  - transmit deviation balance 1:6-17
  - transmitter test pattern 1:6-26
- analog mode
  - receiving 1:3-3
  - transmitting 1:3-8
- antenna
  - attaching 1:8-6
  - removing 1:8-6
- antenna o-ring
  - servicing 1:8-21
- ARM theory of operation 1:3-12
- assemble
  - back chassis assembly 1:8-34
  - bluetooth option board assembly 1:8-36
  - expansion board assembly 1:8-35
  - knobs and top bezel assembly 1:8-31
  - main housing assembly 1:8-34
  - RF board assembly 1:8-33
  - speaker grill assembly 1:8-38
  - top control assembly 1:8-31
  - vocon board assembly 1:8-32
- ASTRO mode
  - receiving 1:3-11
  - transmitting 1:3-11
- audio theory of operation 1:3-13

## B

- back chassis assembly
  - assemble 1:8-34
  - dual display
    - servicing 1:8-25
  - removing 1:8-16
  - top display
    - servicing 1:8-27
- battery
  - attaching 1:8-7
  - removing 1:8-9

- bit error rate test 1:6-24
- bluetooth
  - troubleshooting chart 1:9-5
- bluetooth option board assembly
  - assemble 1:8-36
- bluetooth option/expansion board
  - troubleshooting chart 1:9-4

## C

- chassis ground contact
  - servicing 1:8-21
- chassis pads
  - servicing 1:8-20
- chassis screw boss cap
  - servicing 1:8-20
- cleaning external plastic surfaces 1:2-1
- color display
  - servicing 1:8-25
- control top and keypad test mode, dual-display
  - version 1:5-6
- control top assembly
  - removing 1:8-19
  - servicing 1:8-22
- control top test mode
  - top-display version 1:5-8
- controller
  - ARM theory of operation 1:3-12
  - audio theory of operation 1:3-13
  - theory of operation 1:3-12
  - user interface block theory of operation 1:3-13
- controller expansion bay & option slot theory of operation 1:3-13

## D

- disassembly/reassembly
  - antenna
    - attaching 1:8-6
    - removing 1:8-6
  - back chassis assembly
    - removing 1:8-16
  - battery
    - attaching 1:8-7
    - removing 1:8-9
  - control top assembly
    - removing 1:8-19
  - expansion board assembly
    - removing 1:8-13
  - housing assembly
    - reassembling 1:8-31
  - introduction 1:8-1
  - knobs and top bezel assembly
    - removing 1:8-18
  - main chassis assembly
    - removing 1:8-20
  - main housing assembly
    - removing 1:8-15
  - RF board assembly
    - removing 1:8-17
  - speaker grill assembly
    - removing 1:8-12
  - speaker module

- removing 1:8-13
- universal connector cover
  - attaching 1:8-11
  - removing 1:8-10
- vocon board assembly
  - removing 1:8-18
- display radio
  - test mode
    - test environments 1:5-5
    - test frequencies 1:5-5
- dual-display version
  - control top and keypad test mode 1:5-6
  - entering test mode 1:5-3
  - RF test mode 1:5-5

**E**

- encryption
  - index
    - selecting with keypad 1:7-3
    - selecting with menu 1:7-3
  - key
    - erasing
      - all keys 1:7-4
      - key zeroization 1:7-3
    - selecting with keypad 1:7-2
    - selecting with menu 1:7-2
  - troubleshooting chart 1:9-4
- error codes
  - operational 1:9-2
  - power-up 1:9-1
- expansion bay & option slot theory of operation 1:3-13
- expansion board assembly
  - assemble 1:8-35
  - removing 1:8-13
  - servicing 1:8-25
- exploded view
  - complete
    - dual display version 1:10-2
    - top display version 1:10-4
  - partial
    - dual display 1:8-2
    - top display 1:8-3

**F**

- field programming equipment 1:4-3
- FLASHport 1:1-2

**G**

- grille label
  - servicing 1:8-30

**H**

- handling precautions
  - non-ruggedized radios 1:2-1
  - ruggedized radios 1:2-2
- housing assembly
  - reassembling 1:8-31

**I**

- index, encryption
  - selecting with keypad 1:7-3
  - selecting with menu 1:7-3

**K**

- key, encryption
  - erasing
    - all keys 1:7-4
    - key zeroization 1:7-3
  - loading 1:7-1
  - selecting with keypad 1:7-2
  - selecting with menu 1:7-2
- knobs and top bezel assembly
  - assemble 1:8-31
  - removing 1:8-18
  - servicing 1:8-23

**L**

- loading an encryption key 1:7-1

**M**

- main chassis assembly
  - removing 1:8-20
- main housing
  - dual display
    - servicing 1:8-27
  - top display
    - servicing 1:8-28
- main housing assembly
  - assemble 1:8-34
  - removing 1:8-15
- main lens
  - servicing 1:8-26
- maintenance
  - cleaning 1:2-1
  - inspection 1:2-1
  - ruggedized radio submergibility checks 1:2-1
- manual
  - notations 1:1-1
- microphone membrane
  - servicing 1:8-21, 1:8-29
- model chart
  - 700-800 MHz and UHF1 1:xi
  - 700-800 MHz and UHF2 1:xiv
  - 700-800 MHz and VHF 1:x
  - numbering system 1:ix
  - UHF1 and VHF 1:xii, 1:xiii
  - UHF2 and VHF 1:xv
- model numbering system, radio 1:ix
- multikey
  - conventional 1:7-1
  - trunked 1:7-1

**N**

- notations
  - manual 1:1-1

warning, caution, and danger 1:1-1

## P

### performance checks

receiver 1:5-9  
test setup 1:5-1  
transmitter 1:5-10

### performance test

tuner 1:6-24

### port seal label

servicing 1:8-29

### power-up error codes 1:9-1

### precautions, handling 1:2-1

## R

### radio

alignment 1:6-1  
basic description 1:1-2  
dual-display model  
RF test mode 1:5-5  
dual-display version  
control top and keypad test mode 1:5-6  
entering display test mode 1:5-3  
exploded view  
complete  
top display version 1:10-4  
complete dual display version 1:10-2  
partial  
dual display 1:8-2  
top display 1:8-3  
features 1:1-2  
FLASHport feature 1:1-2  
information screen 1:6-4  
model numbering system 1:ix  
models 1:1-2  
reassembling  
housing assembly 1:8-31  
submergible models  
disassembling 1:8-39  
reassembling 1:8-40  
submersibility  
specialized test equipment 1:8-39  
standards 1:8-39  
vacuum test 1:8-40  
test environments 1:5-5  
test frequencies 1:5-5  
test mode  
dual-display version 1:5-3  
top-display model 1:5-7  
top-display version  
control top test mode 1:5-8  
entering test mode 1:5-7  
RF test mode 1:5-8

### receiver

ASTRO conventional channel tests 1:5-9  
performance checks 1:5-9  
troubleshooting 1:9-2

### receiving

analog mode 1:3-3  
ASTRO mode 1:3-11

### reference oscillator alignment 1:6-4

### RF board assembly

assemble 1:8-33  
removing 1:8-17  
servicing 1:8-24

### RF test mode

dual-display version 1:5-5  
top-display version 1:5-8

### ruggedized radios

handling precautions 1:2-2  
submergibility checks 1:2-1

## S

### service aids 1:4-2

### servicing

antenna o-ring 1:8-21  
back chassis assembly  
dual display 1:8-25  
top display 1:8-27  
chassis ground contact 1:8-21  
chassis pads 1:8-20  
chassis screw boss cap 1:8-20  
color display 1:8-25  
control top assembly 1:8-22  
expansion board assembly 1:8-25  
grille label 1:8-30  
knobs and top bezel assembly 1:8-23  
main housing  
dual display 1:8-27  
top display 1:8-28  
main lens 1:8-26  
microphone membrane 1:8-21, 1:8-29  
port seal label 1:8-29  
RF board assembly 1:8-24  
speaker grille assembly 1:8-30  
speaker module 1:8-29  
speaker seal 1:8-26  
vocon board assembly 1:8-23

### softpot 1:6-2

### speaker grill assembly

assemble 1:8-38  
removing 1:8-12

### speaker grille assembly

servicing 1:8-30

### speaker module

removing 1:8-13  
servicing 1:8-29

### speaker seal

servicing 1:8-26

### specifications

700-800 MHz radios 1:xvii  
UHF1 radios 1:xviii  
UHF2 radios 1:xix  
VHF radios 1:xvi

### standards, radio submersibility 1:8-39

### submergibility

radio disassembly 1:8-39  
radio reassembly 1:8-40

### submersibility

specialized test equipment 1:8-39  
standards 1:8-39  
vacuum test 1:8-40

**T**

- test equipment
  - recommended 1:4-1
  - specialized submersibility 1:8-39
- test mode, entering
  - dual-display version 1:5-3
  - top-display version 1:5-7
- test setup
  - alignment 1:6-1
  - performance checks 1:5-1
- tests
  - receiver
    - ASTRO conventional channels 1:5-9
    - performance checks 1:5-9
  - transmitter
    - ASTRO conventional channels 1:5-11
    - performance checks 1:5-10
- theory of operation
  - analog mode 1:3-3
  - ASTRO mode 1:3-11
  - controller 1:3-12
    - ARM 1:3-12
    - audio 1:3-13
    - expansion bay & option slot 1:3-13
    - user interface block 1:3-13
  - major assemblies 1:3-1
  - overview 1:3-1
- top control assembly
  - assemble 1:8-31
- top-display version
  - control top test mode 1:5-8
  - entering test mode 1:5-7
  - RF test mode 1:5-8
- transmit deviation
  - balance alignment 1:6-17
- transmitter
  - ASTRO conventional channel tests 1:5-11
  - performance checks 1:5-10
  - test pattern 1:6-26
  - troubleshooting 1:9-3
- transmitting
  - analog mode 1:3-8
  - ASTRO mode 1:3-11
- troubleshooting
  - bluetooth option/expansion board problems 1:9-4
  - bluetooth problems 1:9-5
  - encryption problems 1:9-4
  - introduction 1:9-1
  - operational error codes 1:9-2
  - power-up error codes 1:9-1

- receiver problem chart 1:9-2
- transmitter problem chart 1:9-3

tuner

- bit error rate test 1:6-24
- introduction 1:6-1
- main menu 1:6-2
- performance test 1:6-24
- radio information screen 1:6-4
- reference oscillator alignment 1:6-4
- test setup 1:6-1
- transmit deviation balance alignment 1:6-17
- transmitter alignment 1:6-4
- transmitter test pattern 1:6-26

**U**

- UHF Specifications 1:xvii
- UHF1
  - radio specifications 1:xviii
- UHF1 and VHF
  - model chart 1:xii, 1:xiii
- UHF2
  - radio specifications 1:xix
- UHF2 and VHF
  - model chart 1:xv
- universal connector cover
  - attaching 1:8-11
  - removing 1:8-10
- user interface block theory of operation 1:3-13

**V**

- vacuum test, submersibility 1:8-40
- view, exploded
  - complete
    - top display version 1:10-4
    - complete dual display version 1:10-2
  - partial
    - dual display 1:8-2
    - top display 1:8-3
- vocon board assembly
  - assemble 1:8-32
  - removing 1:8-18
  - servicing 1:8-23

**W**

- warning, caution, and danger notations 1:1-1

---

**ASTRO APX 7000/ APX 7000XE**  
**Digital Portable Radios**

Section 2  
APX 7000XE

---

---

## Notes



# Table of Contents

<b>Model Numbering, Charts, and Specifications</b> .....	<b>2:ix</b>
ASTRO APX 7000XE 700–800 MHz and VHF Model Chart.....	2:x
ASTRO APX 7000XE 700–800 MHz and UHF1 Model Chart.....	2:xi
ASTRO APX 7000XE UHF1 and VHF Model Chart.....	2:xii
ASTRO APX 7000XE UHF1 and UHF2 Model Chart.....	2:xiii
ASTRO APX 7000XE 700–800 MHz and UHF2 Model Chart.....	2:xiv
ASTRO APX 7000XE UHF2 and VHF Model Chart.....	2:xv
Specifications for VHF Radios.....	2:xvi
Specifications for 700–800 MHz Radios.....	2:xvii
Specifications for UHF1 Radios.....	2:xviii
Specifications for UHF2 Radios.....	2:xix
<b>Chapter 1 Introduction</b> .....	<b>2:1-1</b>
1.1 Manual Contents.....	2:1-1
1.2 Notations Used in This Manual.....	2:1-1
1.3 Radio Description .....	2:1-2
1.4 FLASHport®.....	2:1-2
<b>Chapter 2 Basic Maintenance</b> .....	<b>2:2-1</b>
2.1 General Maintenance .....	2:2-1
2.2 Handling Precautions.....	2:2-1
<b>Chapter 3 Basic Theory of Operation</b> .....	<b>2:3-1</b>
3.1 Major Assemblies .....	2:3-1
3.2 Analog Mode of Operation.....	2:3-2
3.3 Digital (ASTRO) Mode of Operation .....	2:3-11
3.4 Controller Section .....	2:3-12
<b>Chapter 4 Recommended Test Equipment and Service Aids</b> .....	<b>2:4-1</b>
4.1 Recommended Test Equipment .....	2:4-1
4.2 Service Aids.....	2:4-2
4.3 Field Programming .....	2:4-3
<b>Chapter 5 Performance Checks</b> .....	<b>2:5-1</b>
5.1 Test Equipment Setup .....	2:5-1
5.2 Display Radio Test Mode (Dual-Display Version).....	2:5-3
5.3 Top-Display Version Radio Test Mode .....	2:5-7
5.4 Receiver Performance Checks .....	2:5-9
5.5 Transmitter Performance Checks .....	2:5-10

<b>Chapter 6</b>	<b>Radio Alignment Procedures.....</b>	<b>2:6-1</b>
6.1	Test Setup.....	2:6-1
6.2	Tuner Main Menu.....	2:6-2
6.3	Softpot.....	2:6-2
6.4	Radio Information.....	2:6-4
6.5	Transmitter Alignments.....	2:6-4
6.6	Front End Filter Alignment.....	2:6-22
6.7	Performance Testing.....	2:6-24
<b>Chapter 7</b>	<b>Encryption.....</b>	<b>2:7-1</b>
7.1	Load an Encryption Key.....	2:7-1
7.2	Multikey Feature.....	2:7-1
7.3	Select an Encryption Key.....	2:7-2
7.4	Select an Encryption Index.....	2:7-3
7.5	Erase an Encryption Key.....	2:7-3
<b>Chapter 8</b>	<b>Disassembly/Reassembly Procedures.....</b>	<b>2:8-1</b>
8.1	APX 7000XE Exploded View (Main Subassemblies).....	2:8-1
8.2	Required Tools and Supplies.....	2:8-5
8.3	Fastener Torque Chart.....	2:8-5
8.4	Antenna.....	2:8-6
8.5	Battery.....	2:8-7
8.6	Universal Connector Cover.....	2:8-10
8.7	Radio Disassembly.....	2:8-12
8.8	Serviceable Components of the Main Sub-Assemblies.....	2:8-20
8.9	Radio Reassembly.....	2:8-29
8.10	Ensuring Radio Submergibility.....	2:8-37
<b>Chapter 9</b>	<b>Basic Troubleshooting.....</b>	<b>2:9-1</b>
9.1	Power-Up Error Codes.....	2:9-1
9.2	Operational Error Codes.....	2:9-2
9.3	Receiver Troubleshooting.....	2:9-2
9.4	Transmitter Troubleshooting.....	2:9-3
9.5	Encryption Troubleshooting.....	2:9-4
9.6	Bluetooth Option / Expansion Board Troubleshooting.....	2:9-4
9.7	Bluetooth Troubleshooting.....	2:9-5
<b>Chapter 10</b>	<b>Exploded Views and Parts Lists.....</b>	<b>2:10-1</b>
10.1	APX 7000XE Top Display Exploded View.....	2:10-2
10.2	APX 7000XE Top Display Exploded View Parts List.....	2:10-3
10.3	APX 7000XE Dual Display Exploded View.....	2:10-4
10.4	APX 7000XE Dual Display Exploded View Parts List.....	2:10-5
<b>Index.....</b>		<b>2:Index-1</b>

## List of Tables

Table 1-1.	ASTRO APX 7000XE Basic Features.....	2:1-2
Table 4-1.	Recommended Test Equipment.....	2:4-1
Table 4-2.	Service Aids.....	2:4-2
Table 5-1.	Initial Equipment Control Settings.....	2:5-2
Table 5-2.	Test-Mode Displays.....	2:5-3
Table 5-3.	Test Frequencies (MHz).....	2:5-5
Table 5-4.	Test Environments.....	2:5-5
Table 5-5.	Receiver Performance Checks.....	2:5-9
Table 5-6.	Receiver Tests for ASTRO Conventional Channels*.....	2:5-9
Table 5-7.	Transmitter Performance Checks.....	2:5-10
Table 5-8.	Transmitter Tests for ASTRO Conventional Channels*.....	2:5-11
Table 6-1.	Reference Oscillator Alignment.....	2:6-6
Table 7-1.	Encryption Key Zeroization Options.....	2:7-4
Table 8-1.	APX 7000XE Partial Exploded View Parts List.....	2:8-4
Table 8-2.	Required Tools and Supplies.....	2:8-5
Table 8-3.	Required Tools and Supplies.....	2:8-5
Table 9-1.	Power-Up Error Code Displays.....	2:9-1
Table 9-2.	Operational Error Code Displays.....	2:9-2
Table 9-3.	Receiver Troubleshooting Chart.....	2:9-2
Table 9-4.	Transmitter Troubleshooting Chart.....	2:9-3
Table 9-5.	Encryption Troubleshooting Chart.....	2:9-4
Table 9-6.	Bluetooth Option/Expansion Board Troubleshooting Chart.....	2:9-4
Table 9-7.	Bluetooth Troubleshooting Chart.....	2:9-5
Table 10-1.	APX 7000XE Exploded Views.....	2:10-1
Table 10-2.	Compatibility Table.....	2:10-6

## Related Publications

APX 7000XE Digital Portable Radios User Guide.....	68012002071
APX 7000/ 7000XE Digital Portable Radios Detailed Service Manual.....	6875961M01
APX 7000/ 7000XE Digital Portable Radios User Guide (CD).....	PMLN5335_

## List of Figures

Figure 3-1. APX 7000XE Overall Block Diagram (VOCON Board MNCN6202/ MNCN6203).....	2:3-2
Figure 3-2. Receiver Block Diagram (VHF and 700–800 MHz).....	2:3-3
Figure 3-3. Receiver Block Diagram (UHF1 and 700–800 MHz) .....	2:3-3
Figure 3-4. Receiver Block Diagram (UHF1 and VHF).....	2:3-3
Figure 3-5. Receiver Block Diagram (UHF1 and UHF2) .....	2:3-4
Figure 3-6. Receiver Block Diagram (UHF2 and 700–800 MHz) .....	2:3-4
Figure 3-7. Receiver Block Diagram (UHF2 and VHF).....	2:3-5
Figure 3-8. GPS Diagram .....	2:3-5
Figure 3-9. Transceiver (VHF and 700–800 MHz) Block Diagram .....	2:3-7
Figure 3-10. Transceiver (UHF1 and 700–800 MHz) Block Diagram .....	2:3-8
Figure 3-11. Transceiver (VHF and UHF1) Block Diagram .....	2:3-8
Figure 3-12. Transceiver (UHF1 and UHF2) Block Diagram .....	2:3-9
Figure 3-13. Transceiver (UHF2 and 700–800 MHz) Block Diagram .....	2:3-9
Figure 3-14. Transceiver (VHF and UHF2) Block Diagram .....	2:3-10
Figure 3-15. Controller Block Diagram .....	2:3-12
Figure 5-1. Performance Checks Test Setup.....	2:5-1
Figure 6-1. Radio Alignment Test Setup.....	2:6-1
Figure 6-2. Tuner Software Main Menu .....	2:6-2
Figure 6-3. Typical Softpot Screen .....	2:6-3
Figure 6-4. Radio Information Screen .....	2:6-4
Figure 6-5. Reference Oscillator Alignment Screen (VHF and 700–800 MHz, UHF1 and 700–800 MHz, and UHF2 and 700–800 MHz).....	2:6-5
Figure 6-6. Reference Oscillator Alignment Screen (UHF1 and VHF, and UHF1 and UHF2).....	2:6-5
Figure 6-7. Reference Oscillator Alignment Screen (UHF2 and VHF) .....	2:6-6
Figure 6-8. Transmit Power Characterization Points Alignment Screen (VHF and 700–800 MHz).....	2:6-7
Figure 6-9. Transmit Power Characterization Points Alignment Screen (UHF1 and 700–800 MHz) ...	2:6-8
Figure 6-10. Transmit Power Characterization Points Alignment Screen (UHF1 and VHF).....	2:6-8
Figure 6-11. Transmit Power Characterization Points Alignment Screen (UHF1 and UHF2) .....	2:6-9
Figure 6-12. Transmit Power Characterization Points Alignment Screen (UHF2 and 700–800 MHz) ...	2:6-9
Figure 6-13. Transmit Power Characterization Points Alignment Screen (UHF2 and VHF).....	2:6-10
Figure 6-14. Transmit Power Characterization Alignment Screen (VHF and 700–800 MHz) .....	2:6-11
Figure 6-15. Transmit Power Characterization Alignment Screen (UHF1 and 700–800 MHz) .....	2:6-11
Figure 6-16. Transmit Power Characterization Alignment Screen (UHF1 and VHF) .....	2:6-12
Figure 6-17. Transmit Power Characterization Alignment Screen (UHF1 and UHF2) .....	2:6-12
Figure 6-18. Transmit Power Characterization Alignment Screen (UHF2 and 700–800 MHz) .....	2:6-13
Figure 6-19. Transmit Power Characterization Alignment Screen (UHF2 and VHF) .....	2:6-13
Figure 6-20. PA Saturation Referencing Alignment Screen (VHF and 700–800 MHz) .....	2:6-14
Figure 6-21. PA Saturation Referencing Alignment Screen (UHF1 and 700–800 MHz) .....	2:6-15
Figure 6-22. PA Saturation Referencing Alignment Screen (UHF1 and VHF) .....	2:6-15
Figure 6-23. PA Saturation Referencing Alignment Screen (UHF1 and UHF2) .....	2:6-16
Figure 6-24. PA Saturation Referencing Alignment Screen (UHF2 and 700–800 MHz) .....	2:6-16
Figure 6-25. PA Saturation Referencing Alignment Screen (UHF2 and VHF) .....	2:6-17
Figure 6-26. Transmit Deviation Balance Alignment Screen (VHF and 700–800 MHz).....	2:6-18
Figure 6-27. Transmit Deviation Balance Alignment Screen (UHF1 and 700–800 MHz).....	2:6-19
Figure 6-28. Transmit Deviation Balance Alignment Screen (UHF1 and VHF).....	2:6-19
Figure 6-29. Transmit Deviation Balance Alignment Screen (UHF1 and UHF2).....	2:6-20
Figure 6-30. Transmit Deviation Balance Alignment Screen (UHF2 and 700–800 MHz).....	2:6-20
Figure 6-31. Transmit Deviation Balance Alignment Screen (UHF2 and VHF).....	2:6-21
Figure 6-32. Front End Filter Alignment Screen (UHF1).....	2:6-22
Figure 6-33. Front End Filter Alignment Screen (UHF2).....	2:6-23

---

Figure 6-34. Bit Error Rate Screen.....	2:6-25
Figure 6-35. Transmitter Test Pattern Screen .....	2:6-26
Figure 8-1. APX 7000XE Top Display Partial Exploded View .....	2:8-2
Figure 8-2. APX 7000XE Dual Display Partial Exploded View .....	2:8-3
Figure 8-3. Attaching the Antenna.....	2:8-6
Figure 8-4. Removing the Antenna .....	2:8-6
Figure 8-5. Attaching Battery – Battery Seal .....	2:8-7
Figure 8-6. Attaching Battery – Memory Door.....	2:8-8
Figure 8-7. Attaching Battery – Slide into Position .....	2:8-8
Figure 8-8. Squeezing the Release Latches .....	2:8-9
Figure 8-9. Removing the Battery .....	2:8-9
Figure 8-10. Removing the Thumb Screw.....	2:8-10
Figure 8-11. Engaging Hook and Seating Cover.....	2:8-11
Figure 8-12. Securing the Cover .....	2:8-11
Figure 8-13. Remove Center Screws .....	2:8-12
Figure 8-14. Remove Bottom Screws .....	2:8-12
Figure 8-15. Remove Top Screws .....	2:8-13
Figure 8-16. Remove Speaker Module .....	2:8-13
Figure 8-17. Remove Flex Connectors and Expansion Board Assembly .....	2:8-14
Figure 8-18. Unlock Levers .....	2:8-14
Figure 8-19. Remove Bluetooth Option Board .....	2:8-14
Figure 8-20. Remove Antenna Coax Cable Connector.....	2:8-15
Figure 8-21. Remove Housing .....	2:8-15
Figure 8-22. Remove Back Chassis Assembly from Main Chassis Assembly.....	2:8-16
Figure 8-23. Remove RF Board Assembly.....	2:8-17
Figure 8-24. Remove VOCON Board Assembly .....	2:8-18
Figure 8-25. Remove Knobs and Fastener Hardware.....	2:8-19
Figure 8-26. Remove Control Top Assembly.....	2:8-19
Figure 8-27. Serviceable Components – Main Chassis Assembly.....	2:8-20
Figure 8-28. Remove Chassis Ground Contact .....	2:8-21
Figure 8-29. Control Top Assembly and Control Top Seal .....	2:8-22
Figure 8-30. Frequency and Volume Knobs Assembly .....	2:8-22
Figure 8-31. VOCON Board Assembly.....	2:8-23
Figure 8-32. RF Board Assembly .....	2:8-23
Figure 8-33. Expansion Board Assembly .....	2:8-24
Figure 8-34. Back Chassis Assembly (Dual Display Version).....	2:8-25
Figure 8-35. Back Chassis Assembly (Top Display Version).....	2:8-27
Figure 8-36. Main Housing Assembly .....	2:8-27
Figure 8-37. Speaker Module.....	2:8-28
Figure 8-38. Control Top Bezel Assembly .....	2:8-29
Figure 8-39. Knobs Assembly .....	2:8-29
Figure 8-40. Inspect Pads .....	2:8-30
Figure 8-41. Insert VOCON Board .....	2:8-30
Figure 8-42. Connect RF Board to VOCON Board .....	2:8-31
Figure 8-43. Place Back Chassis .....	2:8-32
Figure 8-44. Place Housing into Main Chassis .....	2:8-32
Figure 8-45. Assemble Expansion Board Assembly .....	2:8-33
Figure 8-46. Insert Flex Connectors.....	2:8-33
Figure 8-47. Assemble Bluetooth Option Board.....	2:8-34
Figure 8-48. Lock Levers.....	2:8-34
Figure 8-49. Lubricate Main Chassis.....	2:8-35
Figure 8-50. Insert Speaker Module .....	2:8-35
Figure 8-51. Insert Top Screws .....	2:8-36
Figure 8-52. Remove Center Screws .....	2:8-36

---

Figure 8-53. Insert Center Screws .....	2:8-36
Figure 8-54. Insert Bottom Screws .....	2:8-37
Figure 8-55. Attaching Grille Eliminator.....	2:8-39
Figure 10-1. APX 7000XE Top Display Exploded View .....	2:10-2
Figure 10-2. APX 7000XE Dual Display Exploded View .....	2:10-4

# Model Numbering, Charts, and Specifications

## Portable Radio Model Numbering System

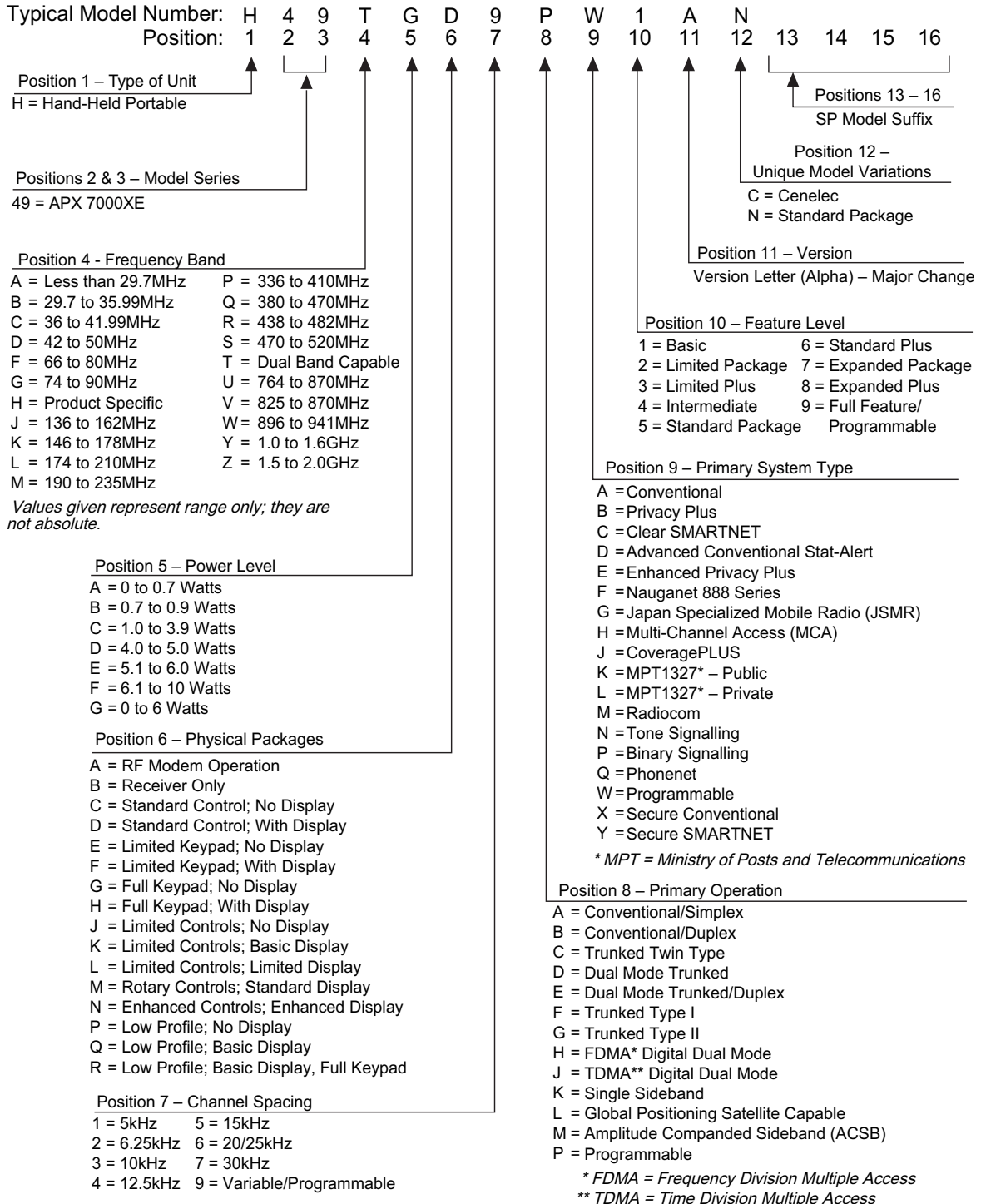

\* FDMA = Frequency Division Multiple Access  
 \*\* TDMA = Time Division Multiple Access

## ASTRO APX 7000XE 700–800 MHz and VHF Model Chart

MODEL NUMBER:		H49TGD9PW1_N	
FCC ID:		AZ489FT7036	
MODEL DESCRIPTION:		700–800 / VHF, APX 7000XE	
Top Display Model			
Dual Display Model			
		ITEM NUMBER	DESCRIPTION
X	X	01009304020	Sub-Assembly, Main Chassis
•	•	NHN7051	Grille, Speaker, Kit_Black
•	•	NHN7053	Grille, Speaker, Kit_Impact Green
•	•	NHN7052	Grille, Speaker, Kit_Safety Yellow
•	•	01009506007	Control Top, Black
•	•	01009506009	Control Top, Impact Green
•	•	01009506008	Control Top, Safety Yellow
•		15009584001	Housing, Assembly Black
•		15009584003	Housing, Assembly Impact Green
•		15009584002	Housing, Assembly Safety Yellow
	•	01009506013	Housing, Assembly Black, Dual Display
	•	01009506015	Housing, Assembly Impact Green, Dual Display
	•	01009506014	Housing, Assembly Safety Yellow, Dual Display
X	X	0375962B01	Screw, Chassis (M2.5 x 0.45 x 31mm)
X	X	0375962B02	Screw, Chassis (M2.5 x 0.45 x 25mm)
X	X	0375962B03	Screw, Chassis (M2.5 x 0.45 x 7.3mm)
X	X	0275891B01	Spanner, Nut, Antenna
X	X	03009357001	Screw, Control Top (M2.5 x 0.45 x 18)
X	X	400129054	Washer, Antenna
X	X	1110027B23	Grease, Fluorocarbon Lubricant
X	X	1575250H01	Cover, Universal Connector
X		1575356H01	Cover, Belt Clip, Top Display
X	X	32009064001	Plug, Controls, Flex Support
X	X	3271829H01	Seal, Battery Connector
X	X	3275623B02	Pad, Thermal, Ring, Outer
X	X	3275882B01	Seal, Memory Card Portal
X	X	3385836D09	Label, Blank, Top/ Dual Display
X		3385836D08	Label, FM, Top Display
	X	3385836D11	Label, FM, Dual Display
X	X	3875126H01	Cap, Chassis Screw Boss
X	X	75009299001	Pad, Thermal, RF, PA Inner (16.7 x 3.7mm)
X	X	7575218H01	Pad, Thermal Expansion / VOCON
X	X	MHLN6977_ / MHLN7035_*	Assembly, Expansion Board
X		MNCN6203_	Assembly, VOCON Board, Top Display
	X	MNCN6202_	Assembly, VOCON Board, Dual Display
X	X	NHN7002_	Assembly, Speaker Module
X		NHN7004_	Sub-Assembly, Back Chassis, Top Display
	X	NHN7017_	Sub-Assembly, Back Chassis, Dual Display
X	X	MNUR4001_	Assembly, RF Board
X		38009295001	Grip, Insert
	X	7575692B01	Keypad
X	X	36009258001	Knob, Frequency
X	X	36009257001	Knob, Volume
X	X	NNTN8160_	Bluetooth Upgrade Kit
Δ	Δ	NUUK6000_	Assembly Bluetooth Option Board
X	X	PMLN5335_	User Guide CD, APX 7000/APX 7000XE

**Note:**

X = Item Included.

• = Option available.

Δ = Comes with unit equipped with Bluetooth Option Board

• Refer [Appendix A](#) for antennas, batteries and other applicable accessories.

\* With TI Chipset.



## ASTRO APX 7000XE 700–800 MHz and UHF1 Model Chart

MODEL NUMBER:		H49TGD9PW1_N	
FCC ID:		AZ489FT7040	
MODEL DESCRIPTION:		700–800 / UHF1, APX 7000XE	
Top Display Model			
Dual Display Model			
		ITEM NUMBER	DESCRIPTION
X	X	01009304020	Sub-Assembly, Main Chassis
●	●	NHN7051	Grille, Speaker, Kit_Black
●	●	NHN7053	Grille, Speaker, Kit_Impact Green
●	●	NHN7052	Grille, Speaker, Kit_Safety Yellow
●	●	01009506007	Control Top, Black
●	●	01009506009	Control Top, Impact Green
●	●	01009506008	Control Top, Safety Yellow
●		15009584001	Housing, Assembly Black
●		15009584003	Housing, Assembly Impact Green
●		15009584002	Housing, Assembly Safety Yellow
	●	01009506013	Housing, Assembly Black, Dual Display
	●	01009506015	Housing, Assembly Impact Green, Dual Display
	●	01009506014	Housing, Assembly Safety Yellow, Dual Display
X	X	0375962B01	Screw, Chassis (M2.5 x 0.45 x 31mm)
X	X	0375962B02	Screw, Chassis (M2.5 x 0.45 x 25mm)
X	X	0375962B03	Screw, Chassis (M2.5 x 0.45 x 7.3mm)
X	X	0275891B01	Spanner, Nut, Antenna
X	X	03009357001	Screw, Control Top (M2.5 x 0.45 x 18)
X	X	400129054	Washer, Antenna
X	X	1110027B23	Grease, Fluorocarbon Lubricant
X	X	1575250H01	Cover, Universal Connector
X		1575356H01	Cover, Belt Clip, Top Display
X	X	32009064001	Plug, Controls, Flex Support
X	X	3271829H01	Seal, Battery Connector
X	X	3275623B02	Pad, Thermal, Ring, Outer
X	X	3275882B01	Seal, Memory Card Portal
X	X	3385836D09	Label, Blank, Top/ Dual Display
X		3385836D08	Label, FM, Top Display
	X	3385836D11	Label, FM, Dual Display
X	X	3875126H01	Cap, Chassis Screw Boss
X	X	75009299001	Pad, Thermal, RF, PA Inner (16.7 x 3.7mm)
X	X	7575218H01	Pad, Thermal Expansion / VOCON
X	X	MHLN6977_ / MHLN7035_*	Assembly, Expansion Board
X		MNCN6203_	Assembly, VOCON Board, Top Display
	X	MNCN6202_	Assembly, VOCON Board, Dual Display
X	X	NHN7002_	Assembly, Speaker Module
X		NHN7004_	Sub-Assembly, Back Chassis, Top Display
	X	NHN7017_	Sub-Assembly, Back Chassis, Dual Display
X	X	MNUS4000_	Assembly, RF Board
X		38009295001	Grip, Insert
	X	7575692B01	Keypad
X	X	36009258001	Knob, Frequency
X	X	36009257001	Knob, Volume
X	X	NNTN8160_	Bluetooth Upgrade Kit
Δ	Δ	NUUK6000_	Assembly Bluetooth Option Board
X	X	PMLN5335_	User Guide CD, APX 7000/APX 7000XE

**Note:**

X = Item Included.

● = Option available.

Δ = Comes with unit equipped with Bluetooth Option Board

\* Refer Appendix A for antennas, batteries and other applicable accessories.

\* With TI Chipset.

## ASTRO APX 7000XE UHF1 and VHF Model Chart

MODEL NUMBER:		H49TGD9PW1_N	
FCC ID:		AZ489FT4886	
MODEL DESCRIPTION:		UHF1 / VHF, APX 7000XE	
Top Display Model			
Dual Display Model			
		ITEM NUMBER	DESCRIPTION
X	X	01009304020	Sub-Assembly, Main Chassis
•	•	NHN7051	Grille, Speaker, Kit_Black
•	•	NHN7053	Grille, Speaker, Kit_Impact Green
•	•	NHN7052	Grille, Speaker, Kit_Safety Yellow
•	•	01009506007	Control Top, Black
•	•	01009506009	Control Top, Impact Green
•	•	01009506008	Control Top, Safety Yellow
•		15009584001	Housing, Assembly Black
•		15009584003	Housing, Assembly Impact Green
•		15009584002	Housing, Assembly Safety Yellow
	•	01009506013	Housing, Assembly Black, Dual Display
	•	01009506015	Housing, Assembly Impact Green, Dual Display
	•	01009506014	Housing, Assembly Safety Yellow, Dual Display
X	X	0375962B01	Screw, Chassis (M2.5 x 0.45 x 31mm)
X	X	0375962B02	Screw, Chassis (M2.5 x 0.45 x 25mm)
X	X	0375962B03	Screw, Chassis (M2.5 x 0.45 x 7.3mm)
X	X	0275891B01	Spanner, Nut, Antenna
X	X	03009357001	Screw, Control Top (M2.5 x 0.45 x 18)
X	X	400129054	Washer, Antenna
X	X	1110027B23	Grease, Fluorocarbon Lubricant
X	X	1575250H01	Cover, Universal Connector
X		1575356H01	Cover, Belt Clip, Top Display
X	X	32009064001	Plug, Controls, Flex Support
X	X	3271829H01	Seal, Battery Connector
X	X	3275623B02	Pad, Thermal, Ring, Outer
X	X	3275882B01	Seal, Memory Card Portal
X	X	3385836D09	Label, Blank, Top/ Dual Display
X		3385836D08	Label, FM, Top Display
	X	3385836D11	Label, FM, Dual Display
X	X	3875126H01	Cap, Chassis Screw Boss
X	X	75009299001	Pad, Thermal, RF, PA Inner (16.7 x 3.7mm)
X	X	7575218H01	Pad, Thermal Expansion / VOCON
X	X	MHLN6977_ / MHLN7035_*	Assembly, Expansion Board
X		MNCN6203_	Assembly, VOCON Board, Top Display
	X	MNCN6202_	Assembly, VOCON Board, Dual Display
X	X	NHN7002_	Assembly, Speaker Module
X		NHN7004_	Sub-Assembly, Back Chassis, Top Display
	X	NHN7017_	Sub-Assembly, Back Chassis, Dual Display
X	X	MNUT4000_	Assembly, RF Board
X		38009295001	Grip, Insert
	X	7575692B01	Keypad
X	X	36009258001	Knob, Frequency
X	X	36009257001	Knob, Volume
X	X	NNTN8160_	Bluetooth Upgrade Kit
Δ	Δ	NUUK6000_	Assembly Bluetooth Option Board
X	X	PMLN5335_	User Guide CD, APX 7000/APX 7000XE

**Note:**

- X = Item Included.
- = Option available.
- Δ = Comes with unit equipped with Bluetooth Option Board
- \* Refer [Appendix A](#) for antennas, batteries and other applicable accessories.
- \* With TI Chipset.

## ASTRO APX 7000XE UHF1 and UHF2 Model Chart

MODEL NUMBER:		H49TGD9PW1_N	
FCC ID:		AZ489FT4906	
MODEL DESCRIPTION:		UHF1 / UHF2, APX 7000XE	
Top Display Model			
Dual Display Model			
		ITEM NUMBER	DESCRIPTION
X	X	01009304020	Sub-Assembly, Main Chassis
●	●	NHN7051	Grille, Speaker, Kit_Black
●	●	NHN7053	Grille, Speaker, Kit_Impact Green
●	●	NHN7052	Grille, Speaker, Kit_Safety Yellow
●	●	01009506007	Control Top, Black
●	●	01009506009	Control Top, Impact Green
●	●	01009506008	Control Top, Safety Yellow
●		15009584001	Housing, Assembly Black
●		15009584003	Housing, Assembly Impact Green
●		15009584002	Housing, Assembly Safety Yellow
	●	01009506013	Housing, Assembly Black, Dual Display
	●	01009506015	Housing, Assembly Impact Green, Dual Display
	●	01009506014	Housing, Assembly Safety Yellow, Dual Display
X	X	0375962B01	Screw, Chassis (M2.5 x 0.45 x 31mm)
X	X	0375962B02	Screw, Chassis (M2.5 x 0.45 x 25mm)
X	X	0375962B03	Screw, Chassis (M2.5 x 0.45 x 7.3mm)
X	X	0275891B01	Spanner, Nut, Antenna
X	X	03009357001	Screw, Control Top (M2.5 x 0.45 x 18)
X	X	400129054	Washer, Antenna
X	X	1110027B23	Grease, Fluorocarbon Lubricant
X	X	1575250H01	Cover, Universal Connector
X		1575356H01	Cover, Belt Clip, Top Display
X	X	32009064001	Plug, Controls, Flex Support
X	X	3271829H01	Seal, Battery Connector
X	X	3275623B02	Pad, Thermal, Ring, Outer
X	X	3275882B01	Seal, Memory Card Portal
X	X	3385836D09	Label, Blank, Top/ Dual Display
X		3385836D08	Label, FM, Top Display
	X	3385836D11	Label, FM, Dual Display
X	X	3875126H01	Cap, Chassis Screw Boss
X	X	75009299001	Pad, Thermal, RF, PA Inner (16.7 x 3.7mm)
X	X	7575218H01	Pad, Thermal Expansion / VOCON
X	X	MHLN6977_ / MHLN7035_*	Assembly, Expansion Board
X		MNCN6203_	Assembly, VOCON Board, Top Display
	X	MNCN6202_	Assembly, VOCON Board, Dual Display
X	X	NHN7002_	Assembly, Speaker Module
X		NHN7004_	Sub-Assembly, Back Chassis, Top Display
	X	NHN7017_	Sub-Assembly, Back Chassis, Dual Display
X	X	MNUE7367_	Assembly, RF Board
X		38009295001	Grip, Insert
	X	7575692B01	Keypad
X	X	36009258001	Knob, Frequency
X	X	36009257001	Knob, Volume
X	X	NNTN8160_	Bluetooth Upgrade Kit
Δ	Δ	NUUK6000_	Assembly Bluetooth Option Board
X	X	PMLN5335_	User Guide CD, APX 7000/APX 7000XE

**Note:**

X = Item Included.

● = Option available.

Δ = Comes with unit equipped with Bluetooth Option Board

\* Refer Appendix A for antennas, batteries and other applicable accessories.

\* With TI Chipset.

## ASTRO APX 7000XE 700–800 MHz and UHF2 Model Chart

MODEL NUMBER:		H49TGD9PW1_N	
FCC ID:		AZ489FT7042	
MODEL DESCRIPTION:		700–800/ UHF2, APX 7000XE	
Top Display Model			
Dual Display Model			
		ITEM NUMBER	DESCRIPTION
X	X	01009304020	Sub-Assembly, Main Chassis
•	•	NHN7051	Grille, Speaker, Kit_Black
•	•	NHN7053	Grille, Speaker, Kit_Impact Green
•	•	NHN7052	Grille, Speaker, Kit_Safety Yellow
•	•	01009506007	Control Top, Black
•	•	01009506009	Control Top, Impact Green
•	•	01009506008	Control Top, Safety Yellow
•		15009584001	Housing, Assembly Black
•		15009584003	Housing, Assembly Impact Green
•		15009584002	Housing, Assembly Safety Yellow
	•	01009506013	Housing, Assembly Black, Dual Display
	•	01009506015	Housing, Assembly Impact Green, Dual Display
	•	01009506014	Housing, Assembly Safety Yellow, Dual Display
X	X	0375962B01	Screw, Chassis (M2.5 x 0.45 x 31mm)
X	X	0375962B02	Screw, Chassis (M2.5 x 0.45 x 25mm)
X	X	0375962B03	Screw, Chassis (M2.5 x 0.45 x 7.3mm)
X	X	0275891B01	Spanner, Nut, Antenna
X	X	03009357001	Screw, Control Top (M2.5 x 0.45 x 18)
X	X	400129054	Washer, Antenna
X	X	1110027B23	Grease, Fluorocarbon Lubricant
X	X	1575250H01	Cover, Universal Connector
X		1575356H01	Cover, Belt Clip, Top Display
X	X	32009064001	Plug, Controls, Flex Support
X	X	3271829H01	Seal, Battery Connector
X	X	3275623B02	Pad, Thermal, Ring, Outer
X	X	3275882B01	Seal, Memory Card Portal
X	X	3385836D09	Label, Blank, Top/ Dual Display
X		3385836D08	Label, FM, Top Display
	X	3385836D11	Label, FM, Dual Display
X	X	3875126H01	Cap, Chassis Screw Boss
X	X	75009299001	Pad, Thermal, RF, PA Inner (16.7 x 3.7mm)
X	X	7575218H01	Pad, Thermal Expansion / VOCON
X	X	MHLN6977_ / MHLN7035_*	Assembly, Expansion Board
X		MNCN6203_	Assembly, VOCON Board, Top Display
	X	MNCN6202_	Assembly, VOCON Board, Dual Display
X	X	NHN7002_	Assembly, Speaker Module
X		NHN7004_	Sub-Assembly, Back Chassis, Top Display
	X	NHN7017_	Sub-Assembly, Back Chassis, Dual Display
X	X	MNUS4002_	Assembly, RF Board
X		38009295001	Grip, Insert
	X	7575692B01	Keypad
X	X	36009258001	Knob, Frequency
X	X	36009257001	Knob, Volume
X	X	NNTN8160_	Bluetooth Upgrade Kit
Δ	Δ	NUUK6000_	Assembly Bluetooth Option Board
X	X	PMLN5335_	User Guide CD, APX 7000/APX 7000XE

**Note:**

X = Item Included.

• = Option available.

Δ = Comes with unit equipped with Bluetooth Option Board

\* Refer Appendix A for antennas, batteries and other applicable accessories.

\* With TI Chipset.

## ASTRO APX 7000XE UHF2 and VHF Model Chart

MODEL NUMBER:		H49TGD9PW1_N	
FCC ID:		AZ489FT4893	
MODEL DESCRIPTION:		UHF2 / VHF, APX 7000XE	
Top Display Model			
Dual Display Model			
		ITEM NUMBER	DESCRIPTION
X	X	01009304020	Sub-Assembly, Main Chassis
●	●	NHN7051	Grille, Speaker, Kit_Black
●	●	NHN7053	Grille, Speaker, Kit_Impact Green
●	●	NHN7052	Grille, Speaker, Kit_Safety Yellow
●	●	01009506007	Control Top, Black
●	●	01009506009	Control Top, Impact Green
●	●	01009506008	Control Top, Safety Yellow
●		15009584001	Housing, Assembly Black
●		15009584003	Housing, Assembly Impact Green
●		15009584002	Housing, Assembly Safety Yellow
	●	01009506013	Housing, Assembly Black, Dual Display
	●	01009506015	Housing, Assembly Impact Green, Dual Display
	●	01009506014	Housing, Assembly Safety Yellow, Dual Display
X	X	0375962B01	Screw, Chassis (M2.5 x 0.45 x 31mm)
X	X	0375962B02	Screw, Chassis (M2.5 x 0.45 x 25mm)
X	X	0375962B03	Screw, Chassis (M2.5 x 0.45 x 7.3mm)
X	X	0275891B01	Spanner, Nut, Antenna
X	X	03009357001	Screw, Control Top (M2.5 x 0.45 x 18)
X	X	400129054	Washer, Antenna
X	X	1110027B23	Grease, Fluorocarbon Lubricant
X	X	1575250H01	Cover, Universal Connector
X		1575356H01	Cover, Belt Clip, Top Display
X	X	32009064001	Plug, Controls, Flex Support
X	X	3271829H01	Seal, Battery Connector
X	X	3275623B02	Pad, Thermal, Ring, Outer
X	X	3275882B01	Seal, Memory Card Portal
X	X	3385836D09	Label, Blank, Top/ Dual Display
X		3385836D08	Label, FM, Top Display
	X	3385836D11	Label, FM, Dual Display
X	X	3875126H01	Cap, Chassis Screw Boss
X	X	75009299001	Pad, Thermal, RF, PA Inner (16.7 x 3.7mm)
X	X	7575218H01	Pad, Thermal Expansion / VOCON
X	X	MHLN6977_ / MHLN7035_*	Assembly, Expansion Board
X		MNCN6203_	Assembly, VOCON Board, Top Display
	X	MNCN6202_	Assembly, VOCON Board, Dual Display
X	X	NHN7002_	Assembly, Speaker Module
X		NHN7004_	Sub-Assembly, Back Chassis, Top Display
	X	NHN7017_	Sub-Assembly, Back Chassis, Dual Display
X	X	MNUT4004_	Assembly, RF Board
X		38009295001	Grip, Insert
	X	7575692B01	Keypad
X	X	36009258001	Knob, Frequency
X	X	36009257001	Knob, Volume
X	X	NNTN8160_	Bluetooth Upgrade Kit
Δ	Δ	NUUK6000_	Assembly Bluetooth Option Board
X	X	PMLN5335_	User Guide CD, APX 7000/APX 7000XE

**Note:**

X = Item Included.

● = Option available.

Δ = Comes with unit equipped with Bluetooth Option Board

\* Refer [Appendix A](#) for antennas, batteries and other applicable accessories.

\* With TI Chipset.

# Specifications for VHF Radios

All specifications are per Telecommunications Industries Association TIA-603 unless otherwise noted.

GENERAL	RECEIVER	TRANSMITTER
<b>Temperature Range:</b> <b>Operating:</b> -30°C to +60°C <b>Storage:</b> -40°C to +85°C  <b>Power Supply:</b> Nickel-Metal-Hydride Battery (NiMH) or Lithium-Ion Battery (Li-Ion)  <b>Battery Voltage:</b> <b>Nominal:</b> 7.5 Vdc <b>Range:</b> 6 to 9 Vdc  <b>Transmit Current Drain (Typical):</b> 2398 mA <b>Receive Current Drain (Rated Audio):</b> 273 mA <b>Standby Current Drain:</b> 142 mA  <b>Recommended IMPRES Battery:</b> Li-Ion (2150mAh, Slim, IP67): PMNN4403_ or Li-Ion (2900mAh, IP67): NNTN7038_ or Li-Ion (4200mAh, Rugged): NNTN7034_ or Li-Ion (4100mAh, Rugged) <sup>2</sup> : NNTN7033_ or NiMH (2100mAh, IP67): NNTN7037_ or NiMH (2100mAh, Rugged): NNTN7573_ or NiMH (2000mAh, IP67) <sup>2</sup> : NNTN7036_ or Li-Ion (2300mAh, Rugged) <sup>2</sup> : NNTN8092_ <sup>1</sup> or NiMH (2000mAh, Rugged) <sup>2</sup> : NNTN7035_  <b>Dimensions<sup>3</sup>:</b> <b>Without Battery (Radio Only):</b> H = 6.94" (176.3 mm) W <sup>4</sup> = 3.32" (84.3 mm) / 2.39" (60.8 mm) D <sup>5</sup> = 1.25" (31.7 mm) / 1.40" (35.6 mm) <b>With Li-Ion Battery<sup>6</sup>:</b> H = 7.20" (182.9 mm) W <sup>4</sup> = 3.32" (84.3 mm) / 2.39" (60.8 mm) D <sup>5</sup> = 1.65" (41.8 mm) / 1.40" (35.6 mm) <b>With NiMH Battery<sup>7</sup>:</b> H = 9.20" (233.7 mm) W <sup>4</sup> = 3.32" (84.3 mm) / 2.39" (60.8 mm) D <sup>5</sup> = 1.64" (41.7 mm) / 1.40" (35.6 mm)  <b>Weight: (w/o Antenna):</b> <b>Less Battery:</b> 15.4 oz (436 g) <b>With Li-Ion<sup>6</sup>:</b> 21.9 oz (620 g) <b>With Li-Ion Ultra High Cap<sup>8</sup>:</b> 26.7 oz (757 g) <b>With NiMH<sup>7</sup>:</b> 27.2 oz (771 g)	<b>Frequency Range:</b> 136–174 MHz  <b>Bandwidth:</b> 38 MHz  <b>Analog Sensitivity (typical) (12 dB SINAD):</b> 0.216 µV  <b>Digital Sensitivity (typical) (1% BER):</b> 0.277 µV <b>(5% BER):</b> 0.188 µV  <b>Intermodulation Rejection (typical):</b> 80.5 dB  <b>Selectivity<sup>9</sup> (typical):</b> <b>(25 kHz Channel):</b> 79.3 dB <b>(12.5 kHz Channel):</b> 70 dB  <b>Spurious Rejection (typical):</b> 93.2 dB  <b>Frequency Stability (-30+60°C; 25°C reference):</b> ±0.0001%  <b>Rated Audio:</b> <b>Internal Speaker:</b> 1 W <b>External Speaker:</b> 500 mW  <b>FM Hum and Noise (typical):</b> 25 kHz -53.8 dB 12.5 kHz -48 dB  <b>Distortion (typical):</b> 1.2%  <b>Channel Spacing:</b> 12.5/20/25 kHz	<b>Frequency Range:</b> 136–174 MHz  <b>RF Power:</b> <b>136–174 MHz:</b> 1–6 Watts  <b>Frequency Stability (-30 to +60°C; 25°C ref.):</b> ±0.0001%  <b>Emission (typical conducted):</b> -75 dBc  <b>FM Hum and Noise (typical):</b> 25 kHz -47 dB 12.5 kHz -45 dB  <b>Distortion (typical):</b> 0.50%  <b>Modulation Limiting:</b> 25 kHz chnls ±5.0 kHz 20 kHz chnls ±4.0 kHz 12.5 kHz chnls ±2.5 kHz  <b>ACPR (typical):</b> 25 kHz -78 dBc 12.5 kHz -68 dBc  <b>Emissions Designators:</b> 11K0F3E, 16K0F3E, 8K10F1D, 8K10F1E, 8K10F1W, 20K0F1E  <b>Note:</b> 1. Default APX 7000XE Battery 2. Intrinsically Safe. 3. H = Height; W = Width; D = Depth. 4. W = (Width @ Top) / (Width @ PTT). 5. D = (Depth @ Bottom) / (Depth @ PTT). 6. Measured with NNTN8092_. 7. Measured with NNTN7035_. 8. Measured with NNTN7033_. 9. Single tone test.

Specifications subject to change without notice.

## Specifications for 700–800 MHz Radios

All specifications are per Telecommunications Industries Association TIA-603 unless otherwise noted.

GENERAL	RECEIVER	TRANSMITTER
<b>Temperature Range:</b> <b>Operating:</b> -30°C to +60°C <b>Storage:</b> -40°C to +85°C  <b>Power Supply:</b> Nickel-Metal-Hydride Battery (NiMH) or Lithium-Ion Battery (Li-Ion)  <b>Battery Voltage:</b> <b>Nominal:</b> 7.5 Vdc <b>Range:</b> 6 to 9 Vdc  <b>Transmit Current Drain (Typical):</b> 1499 mA <b>Receive Current Drain (Rated Audio):</b> 278 mA <b>Standby Current Drain:</b> 148 mA  <b>Recommended IMPRES Battery:</b> <b>Li-Ion (2150mAh, Slim, IP67):</b> PMNN4403_ <b>or Li-Ion (2900mAh, IP67):</b> NNTN7038_ <b>or Li-Ion (4200mAh, Rugged):</b> NNTN7034_ <b>or Li-Ion (4100mAh, Rugged)<sup>2</sup>:</b> NNTN7033_ <b>or NiMH (2100mAh, IP67):</b> NNTN7037_ <b>or NiMH (2100mAh, Rugged):</b> NNTN7573_ <b>or NiMH (2000mAh, IP67)<sup>2</sup>:</b> NNTN7036_ <b>or Li-Ion (2300mAh, Rugged)<sup>2</sup>:</b> NNTN8092_ <sup>1</sup> <b>or NiMH (2000mAh, Rugged)<sup>2</sup>:</b> NNTN7035_  <b>Dimensions<sup>3</sup>:</b> <b>Without Battery (Radio Only):</b> H = 6.94" (176.3 mm) W <sup>4</sup> = 3.32" (84.3 mm) / 2.39" (60.8 mm) D <sup>5</sup> = 1.25" (31.7 mm) / 1.40" (35.6 mm) <b>With Li-Ion Battery<sup>6</sup>:</b> H = 7.20" (182.9 mm) W <sup>4</sup> = 3.32" (84.3 mm) / 2.39" (60.8 mm) D <sup>5</sup> = 1.65" (41.8 mm) / 1.40" (35.6 mm) <b>With NiMH Battery<sup>7</sup>:</b> H = 9.20" (233.7 mm) W <sup>4</sup> = 3.32" (84.3 mm) / 2.39" (60.8 mm) D <sup>5</sup> = 1.64" (41.7 mm) / 1.40" (35.6 mm)  <b>Weight: (w/o Antenna):</b> <b>Less Battery:</b> 15.4 oz (436 g) <b>With Li-Ion<sup>6</sup>:</b> 21.9 oz (620 g) <b>With Li-Ion Ultra High Cap<sup>8</sup>:</b> 26.7 oz (757 g) <b>With NiMH<sup>7</sup>:</b> 27.2 oz (771 g)	<b>Frequency Range:</b> <b>700 MHz:</b> 763–776 MHz <b>800 MHz:</b> 851–870 MHz  <b>Bandwidth:</b> <b>700 MHz:</b> 13 MHz <b>800 MHz:</b> 19 MHz  <b>Analog Sensitivity (typical)</b> <b>(12 dB SINAD):</b> 0.25 µV  <b>Digital Sensitivity (typical)</b> <b>(1% BER 700 / 800 MHz):</b> 0.347/ 0.333 µV <b>(5% BER):</b> 0.251 µV  <b>Intermodulation Rejection (typical):</b> 80 dB  <b>Selectivity<sup>9</sup> (typical):</b> <b>(25 kHz Channel):</b> 75.7 dB <b>(12.5 kHz Channel):</b> 67.5 dB  <b>Spurious Rejection (typical):</b> 76.6 dB  <b>Frequency Stability</b> <b>(-30+60°C; 25°C reference):</b> ±0.0001%  <b>Rated Audio:</b> <b>Internal Speaker:</b> 1 W <b>External Speaker:</b> 500 mW  <b>FM Hum and Noise (typical):</b> 25 kHz -54 dB 12.5 kHz -48 dB  <b>Distortion (typical):</b> 0.9%  <b>Channel Spacing:</b> 12.5/20/25 kHz	<b>Frequency Range:</b> <b>700 MHz:</b> 763–776; 793–806 MHz <b>800 MHz:</b> 806–825; 851–870 MHz  <b>RF Power:</b> <b>700 MHz:</b> 1–2.7 Watts <b>800 MHz:</b> 1–3 Watts  <b>Frequency Stability</b> <b>(-30 to +60°C; 25°C ref.):</b> <b>700 MHz:</b> ±0.0001% <b>800 MHz:</b> ±0.0001%  <b>Emission</b> <b>(typical conducted):</b> -75 dBc  <b>FM Hum and Noise (typical):</b> 25 kHz chnls (700/ 800 MHz): -48 / -47 dB 12.5 kHz chnls (700/ 800 MHz): -46 / -45 dB  <b>Distortion (typical):</b> <b>700 MHz:</b> 0.60% <b>800 MHz:</b> 1%  <b>Modulation Limiting:</b> 25 kHz chnls ±5.0 kHz 20 kHz chnls ±4.0 kHz 12.5 kHz chnls ±2.5 kHz  <b>ACPR (typical):</b> 25 kHz -78 dBc 12.5 kHz -68 dBc  <b>Emissions Designators:</b> 11K0F3E, 16K0F3E, 8K10F1D, 8K10F1E, 8K10F1W, 20K0F1E  <b>Note:</b> 1. Default APX 7000XE Battery 2. Intrinsically Safe. 3. H = Height; W = Width; D = Depth. 4. W = (Width @ Top) / (Width @ PTT). 5. D = (Depth @ Bottom) / (Depth @ PTT). 6. Measured with NNTN8092_. 7. Measured with NNTN7035_. 8. Measured with NNTN7033_. 9. Single tone test.

Specifications subject to change without notice.

## Specifications for UHF1 Radios

All specifications are per Telecommunications Industries Association TIA-603 unless otherwise noted.

**NOTE:** Per the FCC Narrowbanding rules, new products (APX7000 UHF1/ UHF2) submitted for FCC certification after January 1, 2011 are restricted from being granted certification at 25 kHz for United States – State and Local Markets only.

GENERAL	RECEIVER	TRANSMITTER
<b>Temperature Range:</b> <b>Operating:</b> -30°C to +60°C <b>Storage:</b> -40°C to +85°C  <b>Power Supply:</b> Nickel-Metal-Hydride Battery (NiMH) or Lithium-Ion Battery (Li-Ion)  <b>Battery Voltage:</b> <b>Nominal:</b> 7.5 Vdc <b>Range:</b> 6 to 9 Vdc  <b>Transmit Current Drain (Typical):</b> 2060 mA <b>Receive Current Drain (Rated Audio):</b> 273 mA <b>Standby Current Drain:</b> 142 mA  <b>Recommended IMPRES Battery:</b> Li-Ion (2150mAh, Slim, IP67): PMNN4403_ or Li-Ion (2900mAh, IP67): NNTN7038_ or Li-Ion (4200mAh, Rugged): NNTN7034_ or Li-Ion (4100mAh, Rugged) <sup>2</sup> : NNTN7033_ or NiMH (2100mAh, IP67): NNTN7037_ or NiMH (2100mAh, Rugged): NNTN7573_ or NiMH (2000mAh, IP67) <sup>2</sup> : NNTN7036_ or Li-Ion (2300mAh, Rugged) <sup>2</sup> : NNTN8092_ <sup>1</sup> or NiMH (2000mAh, Rugged) <sup>2</sup> : NNTN7035_  <b>Dimensions<sup>3</sup>:</b> <b>Without Battery (Radio Only):</b> H = 6.94" (176.3 mm) W <sup>4</sup> = 3.32" (84.3 mm) / 2.39" (60.8 mm) D <sup>5</sup> = 1.25" (31.7 mm) / 1.40" (35.6 mm) <b>With Li-Ion Battery<sup>6</sup>:</b> H = 7.20" (182.9 mm) W <sup>4</sup> = 3.32" (84.3 mm) / 2.39" (60.8 mm) D <sup>5</sup> = 1.65" (41.8 mm) / 1.40" (35.6 mm) <b>With NiMH Battery<sup>7</sup>:</b> H = 9.20" (233.7 mm) W <sup>4</sup> = 3.32" (84.3 mm) / 2.39" (60.8 mm) D <sup>5</sup> = 1.64" (41.7 mm) / 1.40" (35.6 mm)  <b>Weight: (w/o Antenna):</b> <b>Less Battery:</b> 15.4 oz (436 g) <b>With Li-Ion<sup>6</sup>:</b> 21.9 oz (620 g) <b>With Li-Ion Ultra High Cap<sup>8</sup>:</b> 26.7 oz (757 g) <b>With NiMH<sup>7</sup>:</b> 27.2 oz (771 g)	<b>Frequency Range:</b> 380–470 MHz  <b>Bandwidth:</b> 90 MHz  <b>Analog Sensitivity (typical) (12 dB SINAD):</b> 0.234 µV  <b>Digital Sensitivity (typical) (1% BER):</b> 0.307 µV <b>(5% BER):</b> 0.207 µV  <b>Intermodulation Rejection (typical):</b> 80.2 dB  <b>Selectivity<sup>9</sup> (typical):</b> <b>(25 kHz Channel):</b> 78.3 dB <b>(12.5 kHz Channel):</b> 68.1 dB  <b>Spurious Rejection (typical):</b> 80.3 dB  <b>Frequency Stability (-30+60°C; 25°C reference):</b> ±0.0001%  <b>Rated Audio:</b> <b>Internal Speaker:</b> 1 W <b>External Speaker:</b> 500 mW  <b>FM Hum and Noise (typical):</b> 25 kHz -53.5 dB 12.5 kHz -47.4 dB  <b>Distortion (typical):</b> 0.91 %  <b>Channel Spacing:</b> 12.5/20/25 kHz	<b>Frequency Range:</b> 380–470 MHz  <b>RF Power:</b> <b>380–470 MHz:</b> 1–5 Watts  <b>Frequency Stability (-30 to +60°C; 25°C ref.):</b> ±0.0001%  <b>Emission (typical conducted):</b> -75 dBc  <b>FM Hum and Noise (typical):</b> 25 kHz -47 dB 12.5 kHz -45 dB  <b>Distortion (typical):</b> 0.50%  <b>Modulation Limiting:</b> 25 kHz chnls ±5.0 kHz 20 kHz chnls ±4.0 kHz 12.5 kHz chnls ±2.5 kHz  <b>ACPR (typical):</b> 25 kHz -78 dBc 12.5 kHz -68 dBc  <b>Emissions Designators:</b> 11K0F3E, 16K0F3E, 8K10F1D, 8K10F1E, 8K10F1W, 20K0F1E  <b>Note:</b> 1. Default APX 7000XE Battery 2. Intrinsically Safe. 3. H = Height; W = Width; D = Depth. 4. W = (Width @ Top) / (Width @ PTT). 5. D = (Depth @ Bottom) / (Depth @ PTT). 6. Measured with NNTN8092_. 7. Measured with NNTN7035_. 8. Measured with NNTN7033_. 9. Single tone test.

Specifications subject to change without notice.



## Specifications for UHF2 Radios

All specifications are per Telecommunications Industries Association TIA-603 unless otherwise noted.

**NOTE:** Per the FCC Narrowbanding rules, new products (APX7000 UHF1/ UHF2) submitted for FCC certification after January 1, 2011 are restricted from being granted certification at 25 kHz for United States – State and Local Markets only.

GENERAL	RECEIVER	TRANSMITTER
<b>Temperature Range:</b> <b>Operating:</b> -30°C to +60°C <b>Storage:</b> -40°C to +85°C  <b>Power Supply:</b> Nickel-Metal-Hydrate Battery (NiMH) or Lithium-Ion Battery (Li-Ion)  <b>Battery Voltage:</b> <b>Nominal:</b> 7.5 Vdc <b>Range:</b> 6 to 9 Vdc  <b>Transmit Current Drain (Typical):</b> 2100 mA <b>Receive Current Drain (Rated Audio):</b> 268 mA <b>Standby Current Drain:</b> 137 mA  <b>Recommended IMPRES Battery:</b> <b>Li-Ion (2150mAh, Slim, IP67):</b> PMNN4403_ <b>or Li-Ion (2900mAh, IP67):</b> NNTN7038_ <b>or Li-Ion (4200mAh, Rugged):</b> NNTN7034_ <b>or Li-Ion (4100mAh, Rugged)<sup>2</sup>:</b> NNTN7033_ <b>or NiMH (2100mAh, IP67):</b> NNTN7037_ <b>or NiMH (2100mAh, Rugged):</b> NNTN7573_ <b>or NiMH (2000mAh, IP67)<sup>2</sup>:</b> NNTN7036_ <b>or Li-Ion (2300mAh, Rugged)<sup>2</sup>:</b> NNTN8092_ <sup>1</sup> or <b>NiMH (2000mAh, Rugged)<sup>2</sup>:</b> NNTN7035_  <b>Dimensions<sup>3</sup>:</b> <b>Without Battery (Radio Only):</b> H = 6.94" (176.3 mm) W <sup>4</sup> = 3.32" (84.3 mm) / 2.39" (60.8 mm) D <sup>5</sup> = 1.25" (31.7 mm) / 1.40" (35.6 mm) <b>With Li-Ion Battery<sup>6</sup>:</b> H = 7.20" (182.9 mm) W <sup>4</sup> = 3.32" (84.3 mm) / 2.39" (60.8 mm) D <sup>5</sup> = 1.65" (41.8 mm) / 1.40" (35.6 mm) <b>With NiMH Battery<sup>7</sup>:</b> H = 9.20" (233.7 mm) W <sup>4</sup> = 3.32" (84.3 mm) / 2.39" (60.8 mm) D <sup>5</sup> = 1.64" (41.7 mm) / 1.40" (35.6 mm)  <b>Weight: (w/o Antenna):</b> <b>Less Battery:</b> 15.4 oz (436 g) <b>With Li-Ion<sup>6</sup>:</b> 21.9 oz (620 g) <b>With Li-Ion Ultra High Cap<sup>8</sup>:</b> 26.7 oz (757 g) <b>With NiMH<sup>7</sup>:</b> 27.2 oz (771 g)	<b>Frequency Range:</b> 450–520 MHz  <b>Bandwidth:</b> 70 MHz  <b>Analog Sensitivity (typical) (12 dB SINAD):</b> 0.234 µV  <b>Digital Sensitivity (typical) (1% BER):</b> 0.307 µV <b>(5% BER):</b> 0.207 µV  <b>Intermodulation Rejection (typical):</b> 80.2 dB  <b>Selectivity<sup>9</sup> (typical):</b> <b>(25 kHz Channel):</b> 78.3 dB <b>(12.5 kHz Channel):</b> 67.5 dB  <b>Spurious Rejection (typical):</b> 80.3 dB  <b>Frequency Stability (-30+60°C; 25°C reference):</b> ±0.0001%  <b>Rated Audio:</b> <b>Internal Speaker:</b> 1 W <b>External Speaker:</b> 500 mW  <b>FM Hum and Noise (typical):</b> 25 kHz -53.5 dB 12.5 kHz -47.4 dB  <b>Distortion (typical):</b> 0.91 %  <b>Channel Spacing:</b> 12.5/20/25 kHz	<b>Frequency Range:</b> 450–520 MHz  <b>RF Power:</b> <b>450–520 MHz:</b> 1–5 Watts  <b>Frequency Stability (-30 to +60°C; 25°C ref.):</b> ±0.0001%  <b>Emission (typical conducted):</b> -75 dBc  <b>FM Hum and Noise (typical):</b> 25 kHz -47 dB 12.5 kHz -45 dB  <b>Distortion (typical):</b> 0.50%  <b>Modulation Limiting:</b> 25 kHz chnls ±5.0 kHz 20 kHz chnls ±4.0 kHz 12.5 kHz chnls ±2.5 kHz  <b>ACPR (typical):</b> 25 kHz -78 dBc 12.5 kHz -68 dBc  <b>Emissions Designators:</b> 11K0F3E, 16K0F3E, 8K10F1D, 8K10F1E, 8K10F1W, 20K0F1E  <b>Note:</b> 1. Default APX 7000XE Battery 2. Intrinsically Safe. 3. H = Height; W = Width; D = Depth. 4. W = (Width @ Top) / (Width @ PTT). 5. D = (Depth @ Bottom) / (Depth @ PTT). 6. Measured with NNTN8092_ 7. Measured with NNTN7035_ 8. Measured with NNTN7033_ 9. Single tone test.

Specifications subject to change without notice.

## Notes

---

# Chapter 1 Introduction

This manual contains information needed for Levels One and Two radio servicing. Level One servicing consists of radio programming, radio alignment, knobs replacement, and installation and removal of the antenna, belt clip, battery, and universal connector cover. Level Two servicing covers disassembly and reassembly of the radio to replace circuit boards.

## 1.1 Manual Contents

Included in this manual are radio specifications for the VHF(136–174 MHz), UHF1 (380–470 MHz), UHF2 (450–520 MHz) and 764–870 MHz frequency bands, a general description of ASTRO APX 7000XE models, recommended test equipment, service aids, radio alignment procedures, general maintenance recommendations, procedures for assembly and disassembly, and exploded views and parts lists.

## 1.2 Notations Used in This Manual

Throughout the text in this publication, you will notice the use of note, caution, warning, and danger notations. These notations are used to emphasize that safety hazards exist, and due care must be taken and observed.

**NOTE:** An operational procedure, practice, or condition that is essential to emphasize.



Caution

CAUTION indicates a potentially hazardous situation which, if not avoided, might result in equipment damage.



WARNING

**WARNING** indicates a potentially hazardous situation which, if not avoided, could result in death or injury.



DANGER

**DANGER** indicates an imminently hazardous situation which, if not avoided, will result in death or injury.

### 1.3 Radio Description

The ASTRO APX 7000XE radios are among the most sophisticated two-way radios available. These dual band radios are capable of operating in both VHF (136–174 MHz) and 764–870 MHz frequency bands, UHF1 (380–470 MHz) and 764–870 MHz frequency bands, VHF (136–174 MHz) and UHF1 (380–470 MHz) frequency bands, UHF1 (380–450 MHz) and UHF2 (450–520 MHz) frequency bands, UHF2 (450–520 MHz) and 764–870 MHz frequency bands, and, VHF (136–174 MHz) and UHF2 (450–520 MHz) frequency bands.

The ASTRO APX 7000XE radio provides improved voice quality across more coverage area. The digital process, called *embedded signaling*, intermixes system signaling information with digital voice, resulting in improved system reliability and the capability of supporting a multitude of advanced features.

ASTRO APX 7000XE radios are available in two configurations – Top Display and Dual Display. [Table 1-1](#) describes the basic features.

Table 1-1. ASTRO APX 7000XE Basic Features

Feature	Top-Display	Dual-Display
Display	LCD (monochrome) Fully bit-mapped  <u>Top Display:</u> <ul style="list-style-type: none"> <li>• 1 line of text (8 characters per line)</li> <li>• 1 line of icons</li> </ul>	LCD <ul style="list-style-type: none"> <li>• Top Display – monochrome</li> <li>• Front Display – color</li> </ul> Fully bit-mapped  <u>Top Display:</u> <ul style="list-style-type: none"> <li>• 1 line of text (8 characters per line)</li> <li>• 1 line of icons</li> </ul> <u>Front Display:</u> <ul style="list-style-type: none"> <li><i>Dispatch Mode:</i> <ul style="list-style-type: none"> <li>• 5 lines of text (14 characters per line)</li> </ul> </li> <li><i>List Feature Mode:</i> <ul style="list-style-type: none"> <li>• 8 lines of text (14 characters per line)</li> <li>• 2 lines of icons</li> </ul> </li> </ul>
Keypad	None	3 x 2 Menu Buttons (with 4-way Navigation button),  3 x 4 Alphanumeric Keypad
Channel Capability	96 (Basic Zone Bank) 1200 (Enhanced Zone Bank)	2000
Dialing from Prestored List	No	Yes
Programmable Softkeys	No	Yes

### 1.4 FLASHport®

The ASTRO APX 7000XE radio utilizes Motorola’s FLASHport technology. FLASHport makes it possible to add software that drives the radio’s capabilities both at the time of purchase and later on. Previously, changing a radio’s features and capabilities meant significant modifications or buying a new radio. But now, similar to how a computer can be loaded with different software, the radio’s features and capabilities can be upgraded with FLASHport software.

---

## Chapter 2 Basic Maintenance

This chapter describes preventive maintenance and handling precautions. Each of these topics provides information vital to the successful operation and maintenance of your radio.

### 2.1 General Maintenance

In order to avoid operating outside the limits set by the FCC, we recommend that you align the ASTRO APX 7000XE radio's reference oscillator every time the radio is taken apart, or once per year, whichever comes first. (See Section [“6.5.1 Reference Oscillator Alignment”](#) on page 2:6-4). Periodic visual inspection and cleaning is also recommended.

**For APX 7000XE Radios** – Radio submergibility should be checked annually by qualified service technicians.

#### 2.1.1 Inspection

Check that the external surfaces of the radio are clean and that all external controls and switches are functional. A detailed inspection of the interior electronic circuitry is not needed.

#### 2.1.2 Cleaning

The following procedures describe the recommended cleaning agents and the methods to be used when cleaning the external surfaces of the radio. External surfaces include the housing assembly and battery case. These surfaces should be cleaned whenever a periodic visual inspection reveals the presence of smudges, grease, and/or grime.

The only recommended agent for cleaning the external radio surfaces is a 0.5% solution of a mild dishwashing detergent in water.



Caution

Use all chemicals as prescribed by the manufacturer. Be sure to follow all safety precautions as defined on the label or material safety data sheet.

The effects of certain chemicals and their vapors can have harmful results on certain plastics. Aerosol sprays, tuner cleaners, and other chemicals should be avoided.

The detergent-water solution should be applied sparingly with a stiff, non-metallic, short-bristled brush to work all loose dirt away from the radio. A soft, absorbent, lintless cloth or tissue should be used to remove the solution and dry the radio. Make sure that no water remains entrapped near the connectors, cracks, or crevices.

### 2.2 Handling Precautions

Complementary metal-oxide semiconductor (CMOS) devices, and other high-technology devices, are used in this family of radios. While the attributes of these devices are many, their characteristics make them susceptible to damage by electrostatic discharge (ESD) or high-voltage charges. Damage can be latent, resulting in failures occurring weeks or months later. Therefore, special precautions must be taken to prevent device damage during disassembly, troubleshooting, and repair. Handling precautions are mandatory for this radio, and are especially important in low-humidity conditions.



Caution

- The APX 7000XE radio has a vent port that allows for pressure equalization in the radio. Never poke this vent with any objects, such as needles, tweezers, or screwdrivers. This could create a leak path into the radio and, the radio's submergibility will be lost.
- The pressure equalization vent is located under the main speaker grille near the top left side. Never obstruct or cover the small opening on the top left with any object, including a label. Ensure that no oily substances come in contact with this vent.
- APX 7000XE radio is designed to be submerged to a maximum depth of six (6) feet, with a maximum submersion time of 2 hours per U.S. MIL-STD. Exceeding either maximum limit may result in damage to the radio. For specific U.S. MIL-STD details, see Section ["8.10 Ensuring Radio Submergibility"](#) on [page 2:8-37](#).

### 2.2.1 APX 7000XE Radios Only

If the radio battery contact area has been submerged in water, dry and clean the radio battery contacts before attaching a battery to the radio. Otherwise, the water could short-circuit the radio.

If the radio has been submerged in water, shake the radio briskly so that any water that is trapped inside the speaker grille and microphone port can be removed. Otherwise, the water will decrease the audio quality of the radio.

## Chapter 3 Basic Theory of Operation

This chapter discusses the basic operational theory of the ASTRO APX 7000XE radio, which is a wideband, synthesized radio available in the VHF (136–174 MHz), UHF1 (380–470 MHz), UHF2 (450–520 MHz), 764 to 870 MHz, VHF/764 to 870 MHz, UHF1/764 to 870 MHz and VHF/UHF1, UHF1/UHF2, UHF2/764 to 870 MHz and VHF/UHF2, frequency bands.

All ASTRO APX 7000XE radios are capable of both analog operation (12.5 kHz or 25 kHz bandwidths), ASTRO mode (digital) operation (12.5 kHz only) and X2-TDMA mode (25 kHz only).

### 3.1 Major Assemblies

The ASTRO APX 7000XE radio includes the following major assemblies (see [Figure 3-1](#)):

- **VOCON Board** – contains a dual-core processor which includes both the microcontroller unit (MCU) and a digital signal processor (DSP) core, the processor's memory devices, an audio and power supply support integrated circuit (IC), a digital support IC, external audio power amplifier, and Type III secure IC.
- **Transceiver (XCVR) Board** – contains all transmit, receive, and frequency generation circuitry, including the digital receiver back-end IC and the reference oscillator.
- **Expander Board** – contains the internal audio power amplifier circuitry and the Global Positioning System (GPS) IC and support circuitry.
- **Bluetooth Board** – contains a microprocessor and memory, Bluetooth circuitry, MPP (Motorola Proximity Pairing) circuitry, and an accelerometer.
- **Top Display** – 112 pixels x 32 pixels, transfective monochrome liquid crystal display (LCD).
- **Control Top** – contains five switches: On/Off & Volume Knob, a 16 position Channel/Frequency Knob with concentric 2 position switch (for Secure Enable/Disable operation), a 3 position toggle switch for Zone Selection, and a push button switch used for Emergency calling. The control top also includes an TX/RX LED that is solid amber upon receive, red on PTT, and blinks amber on secure TX/RX.
- **Front Display (Dual-Display Version only)** – 320 pixels x 240 pixels, transfective color LCD.
- **Keypad (Dual-Display Version Only)** – Dual-Display version has a 3 x 2 Menu keypad with 4-way navigation button, and a 3 x 4 alphanumeric keypad.

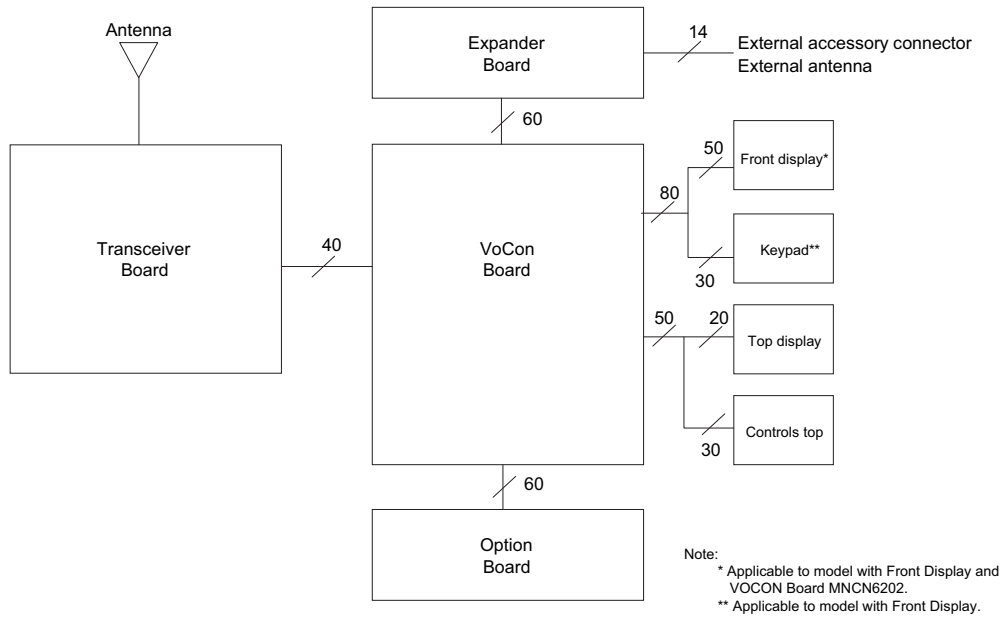

Figure 3-1. APX 7000XE Overall Block Diagram (VOCON Board MNCN6202/ MNCN6203)

### 3.2 Analog Mode of Operation

This section provides an overview of the analog mode receive and transmit theory of operation.

#### 3.2.1 Receiving

The RF signal is *received* at the antenna and is routed through the Auxiliary and Multi Switch (SP3T) ICs. The latter contains a switchable attenuator that is enabled at predetermined RF power thresholds present at the antenna port. The output of the Multi-switch IC is applied to the first SPST band select switch to select either VHF or 700,800 bands (see Figure 3-2), UHF1 or 700,800 bands (see Figure 3-3), VHF or UHF1 bands (see Figure 3-4), UHF1 or UHF2 bands (see Figure 3-5), UHF2 or 700,800 bands (see Figure 3-6) and VHF or UHF2 bands (see Figure 3-7).

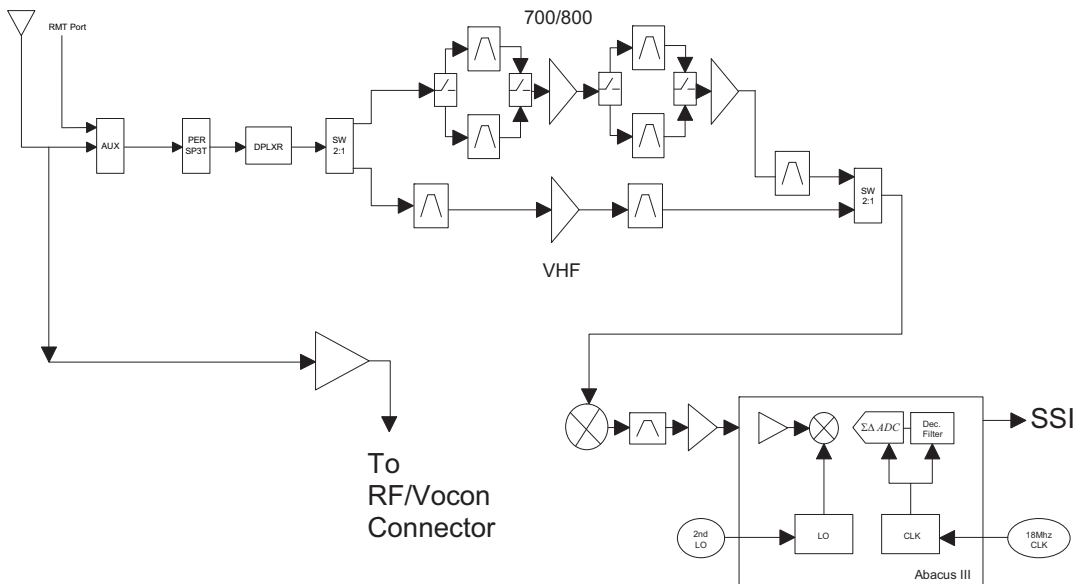



Figure 3-2. Receiver Block Diagram (VHF and 700–800 MHz)

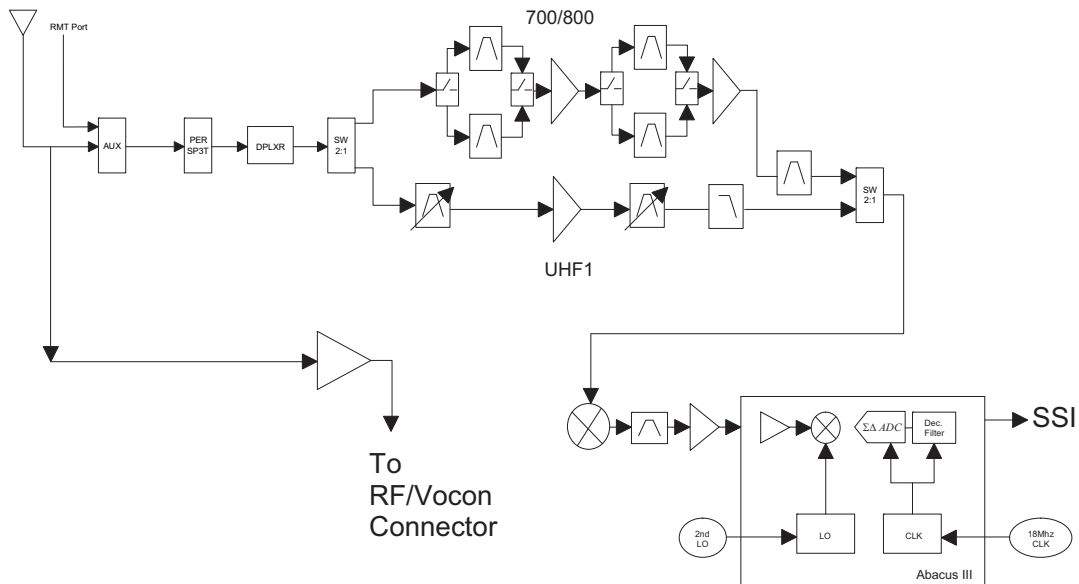

Figure 3-3. Receiver Block Diagram (UHF1 and 700–800 MHz)

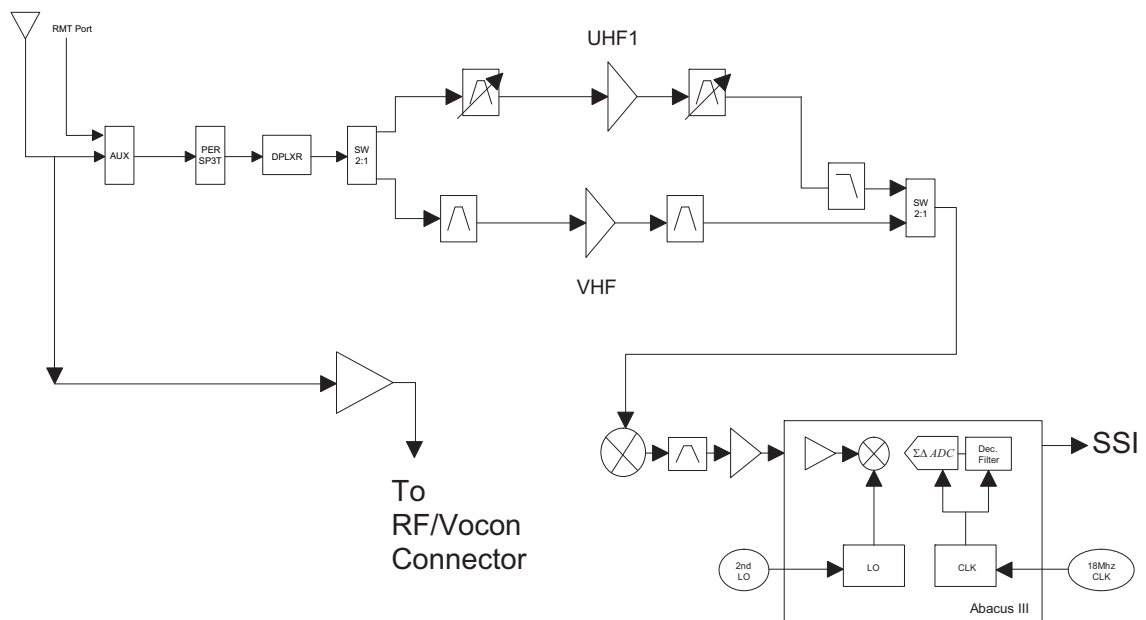

Figure 3-4. Receiver Block Diagram (UHF1 and VHF)

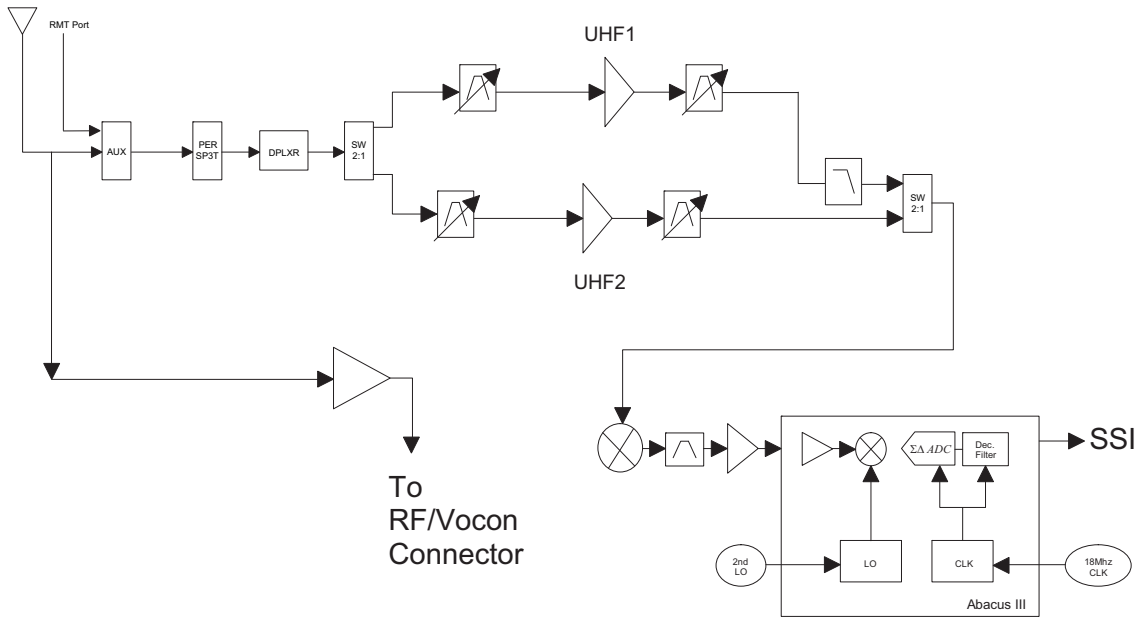

Figure 3-5. Receiver Block Diagram (UHF1 and UHF2)

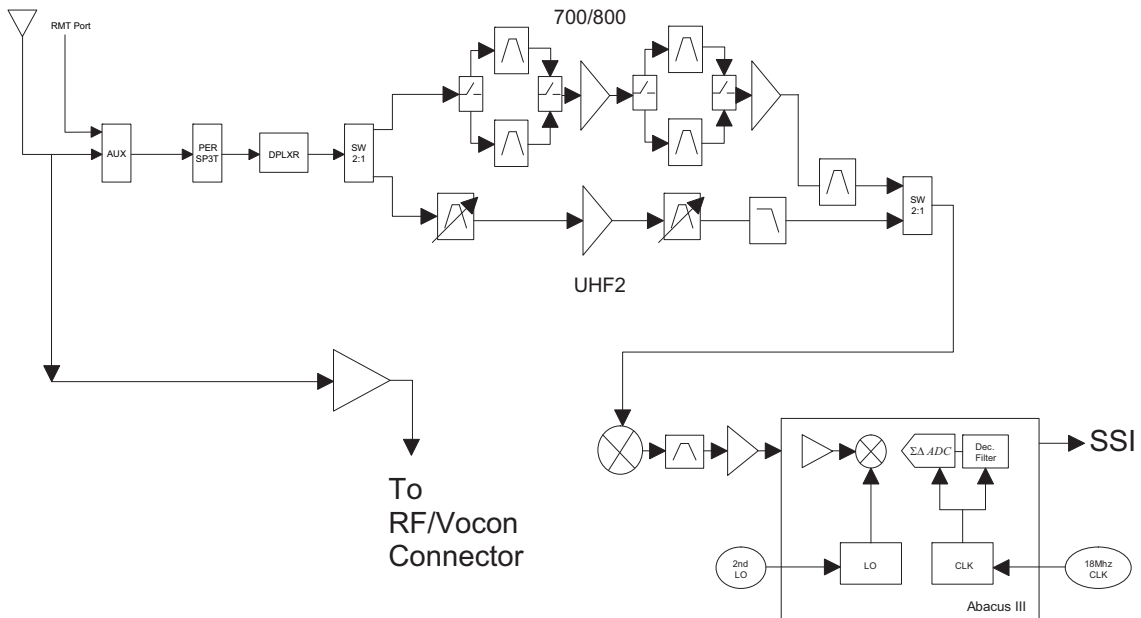

Figure 3-6. Receiver Block Diagram (UHF2 and 700–800 MHz)

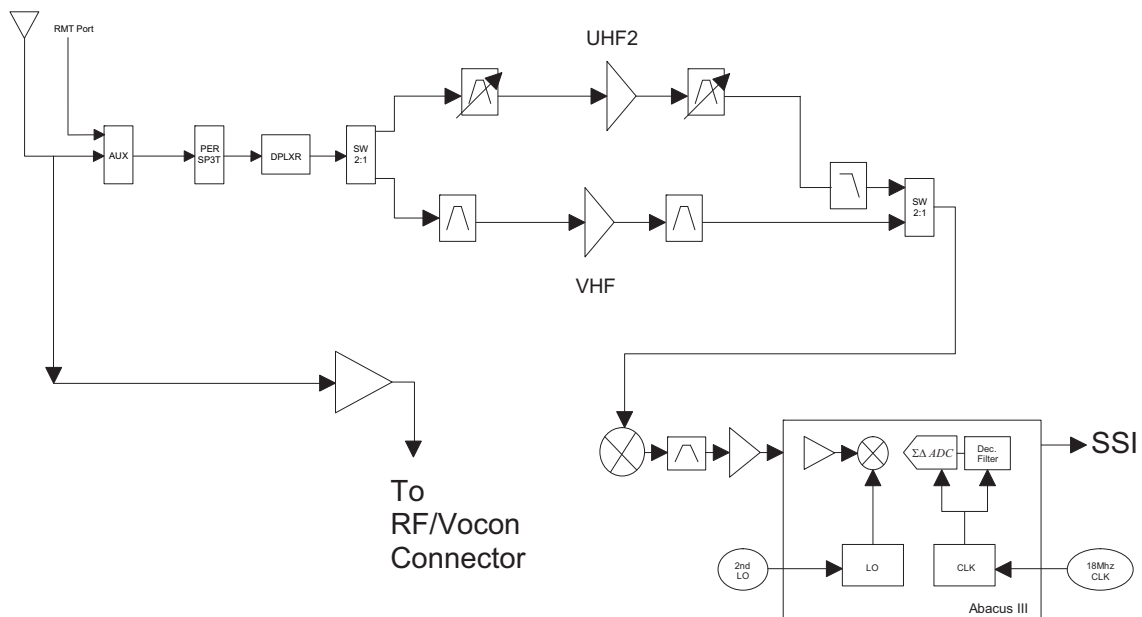

Figure 3-7. Receiver Block Diagram (UHF2 and VHF)

### 3.2.1.1 GPS

The GPS architecture employs a single chip GPS receiver which decodes GPS signals at 1575.42 MHz. It is capable of producing a final position solution including full tracking and data decode capability. The GPS receiver will operate in the autonomous mode only.

The GPS signal is tapped at the antenna port via a series resonant network which provides a very low capacitive load to the transceiver. The signal is routed through a GPS LNA and its output is applied to the RF-Controller interface connector where it is eventually routed to the expansion board for processing by the GPS IC.

The GPS receiver is setup in an autonomous one track always (OTA) mode, also known as continuous navigation. This means the GPS will continuously track satellites for as long as the radio is powered to ensure the best possible accuracy. In the event the radio loses visibility of the satellites due to terrain or environmental factors such as driving through a tunnel or entering a building, the GPS will temporarily lose its position fix. A power savings algorithm will then cycle the GPS in and out of a sleep mode at approximately 90 second intervals until the radio has moved back into an environment where GPS signals are present.

The user will be able to view the current latitude, longitude, and time/date stamp on the radio's display. The radio can also be configured to send its' location to the system at predetermined intervals (LRRP). Depending on system options, the user may be able to enable/disable the GPS receiver.

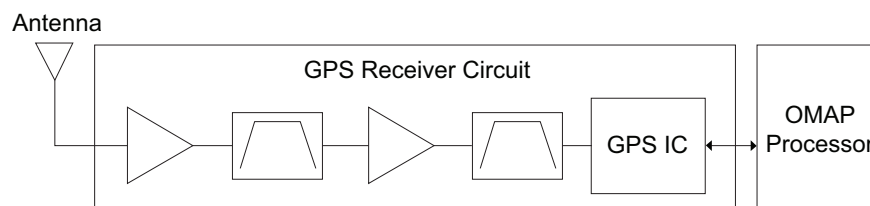

Figure 3-8. GPS Diagram

### 3.2.1.2 VHF Front-End

From the first band select switch, a VHF signal is routed to the first pre-selector filter followed by an LNA and a second pre-selector filter. Both filters are discrete and fixed designs and are used to band limit the incoming energy and suppress known spurious responses such as Image and the  $\frac{1}{2}$  IF spur. The output of the second pre-selector filter is applied to the RF port of the Mixer IC via a second VHF/700,800 or VHF/UHF1 or VHF/UHF2 band select switch. The Mixer IC is also excited by a Local Oscillator (LO) signal at the LO port to down-convert the RF signal to a 109.65 MHz intermediate frequency (IF). The down converted IF signal is passed through a crystal filter and IF amplifier which drives the input of the Abacus 3 Analog to Digital Converter IC (AD9864).

### 3.2.1.3 700/800 MHz Front-End

From the first band select switch, a 700 MHz or 800 MHz band signal is routed to a second band SPST switch which selects the 700 or the 800 band signal and routes it to the appropriate first pre-selector filter. A third band select switch selects the output of the appropriate filter and applies it to an LNA followed by a similar pre-selector filter/ band-select switch circuit. The signal is then routed to second LNA whose output is applied to a discrete image filter. Both preselector filters are Surface Acoustic Wave designs used to band limit the received energy and suppress known spurious responses such as Image and the  $\frac{1}{2}$  IF spur. The output of the discrete image filter is applied to the RF port of the Mixer IC via a second VHF/700,800 or UHF1/700,800 or UHF2/700,800 band select switch. The Mixer IC is also excited by a Local Oscillator (LO) signal at the LO port to down-convert the RF signal to a 109.65 MHz intermediate frequency (IF). The down converted IF signal is passed through a crystal filter and IF amplifier which drives the input of the Abacus 3 Analog to Digital Converter IC (AD9864).

### 3.2.1.4 UHF1 Front-End

From the first band select switch, a UHF1 signal is routed to the first pre-selector filter followed by an LNA and a second pre-selector filter. Both filters are discrete and tunable designs and are used to band limit the incoming energy and suppress known spurious responses such as Image spur. The output of the second pre-selector filter is applied to the RF port of the Mixer IC via a second UHF1/700,800 or UHF1/VHF or UHF1/UHF2 band select switch. The Mixer IC is also excited by a Local Oscillator (LO) signal at the LO port to down-convert the RF signal to a 109.65 MHz intermediate frequency (IF). The down converted IF signal is passed through a crystal filter and IF amplifier which drives the input of the Abacus 3 Analog to Digital Converter IC (AD9864).

### 3.2.1.5 UHF2 Front-End

From the first band select switch, a UHF1 signal is routed to the first pre-selector filter followed by a Low Noise Amplifier (LNA) and a second pre-selector filter. Both filters are discrete and tunable designs and are used to band limit the incoming energy and suppress known spurious responses such as Image spur. The output of the second pre-selector filter is applied to a discrete Low Pass Filter (LPF). The output of the LPF is applied to the RF port of the Mixer IC via a second UHF2/700,800 or UHF1/UHF2 or VHF/UHF2 band select switch. The Mixer IC, is driven by a Local Oscillator (LO) signal generated by the Trident synthesizer IC, at the LO port to down-convert the RF signal to a 109.65 MHz intermediate frequency (IF). It is a passive, high linearity design with balanced inputs at the RF and IF ports and internal LO buffer. The down converted IF signal is passed through a 3-pole crystal filter and an IF amplifier, which drives the input of the Analog to Digital Converter IC.

### 3.2.1.6 Analog To Digital Converter

The ADC IC's front end down converts the first IF to a second IF, a 2.25 MHz signal. The second IF is sampled at 18 MHz, a signal generated by an integrated clock synthesizer. The sampled signal is decimated by a factor of 900 to 20 kHz and converted to SSI format at the ADC's output. The Serial Synchronous Interface (SSI) serial data waveform is composed of a 16 bit in-phase word (I) followed by a 16 bit Quadrature word (Q). A 20 kHz Frame Synch and a 1.2 MHz clock waveform are used to synchronize the SSI IQ data transfer to the Digital Signal Processor IC (OMAP) for post-processing and demodulation.

### 3.2.2 Transmitting

When the radio is transmitting, microphone audio is digitized and then processed by the DSP and sent to the Trident IC (see Figure 3-9 to Figure 3-14) via the SSI interface. The Trident IC processes the SSI data for application to the voltage controlled oscillator as a modulation signal.

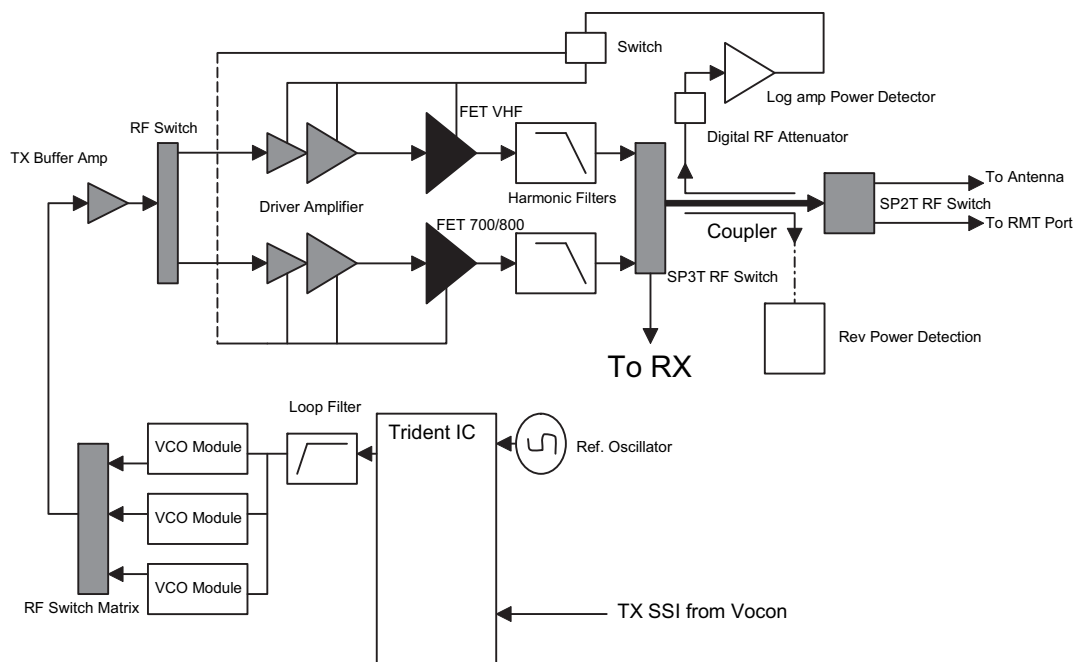

Figure 3-9. Transceiver (VHF and 700–800 MHz) Block Diagram

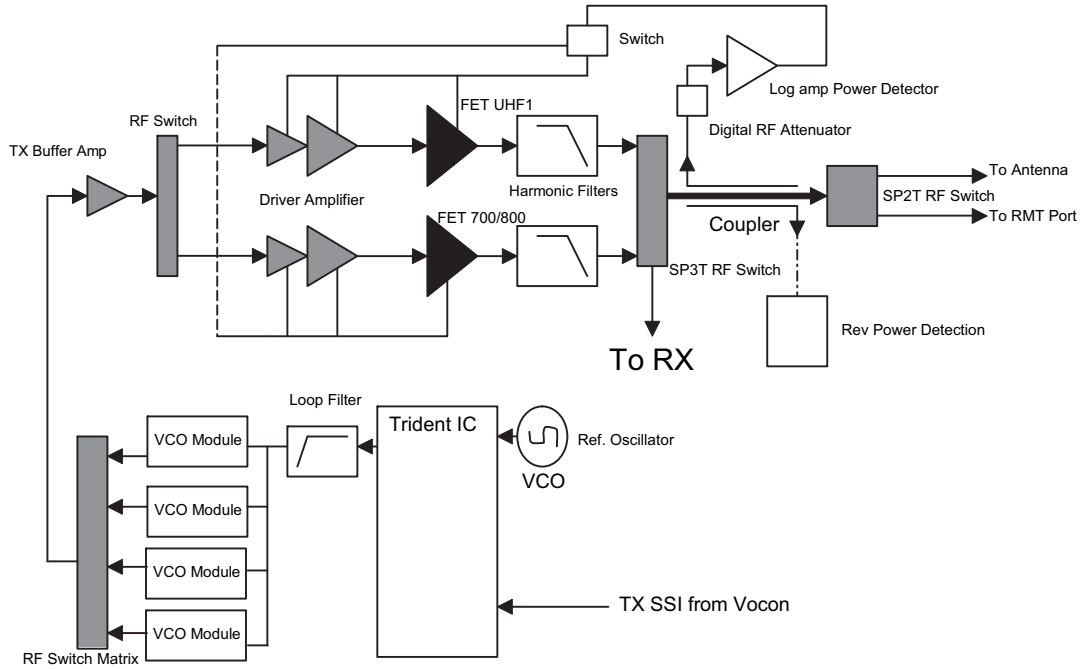

Figure 3-10. Transceiver (UHF1 and 700–800 MHz) Block Diagram

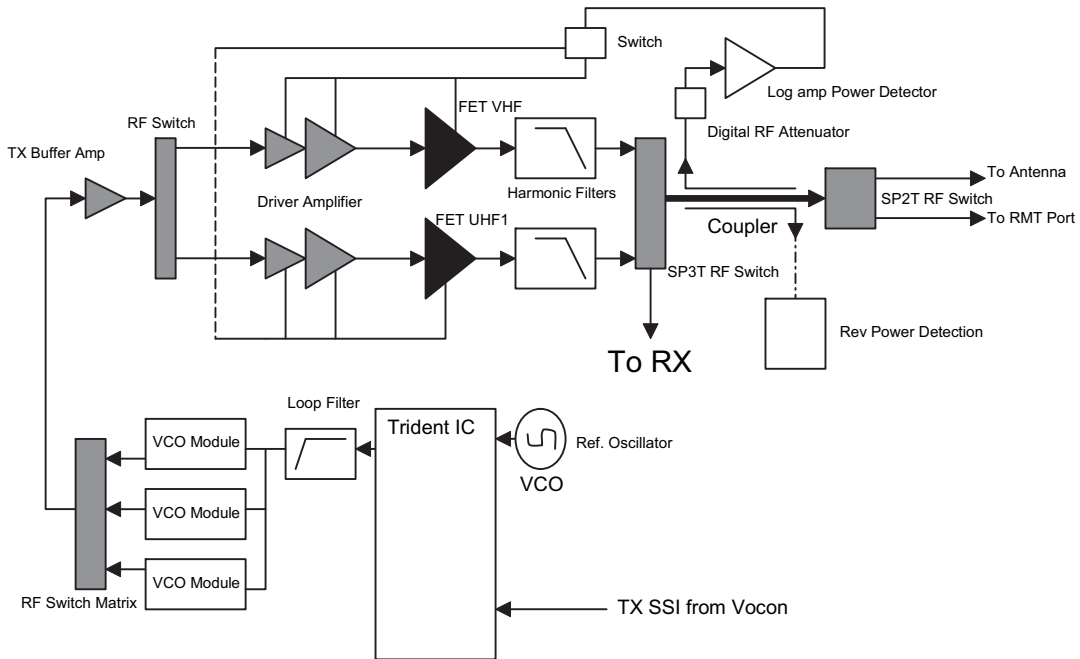

Figure 3-11. Transceiver (VHF and UHF1) Block Diagram

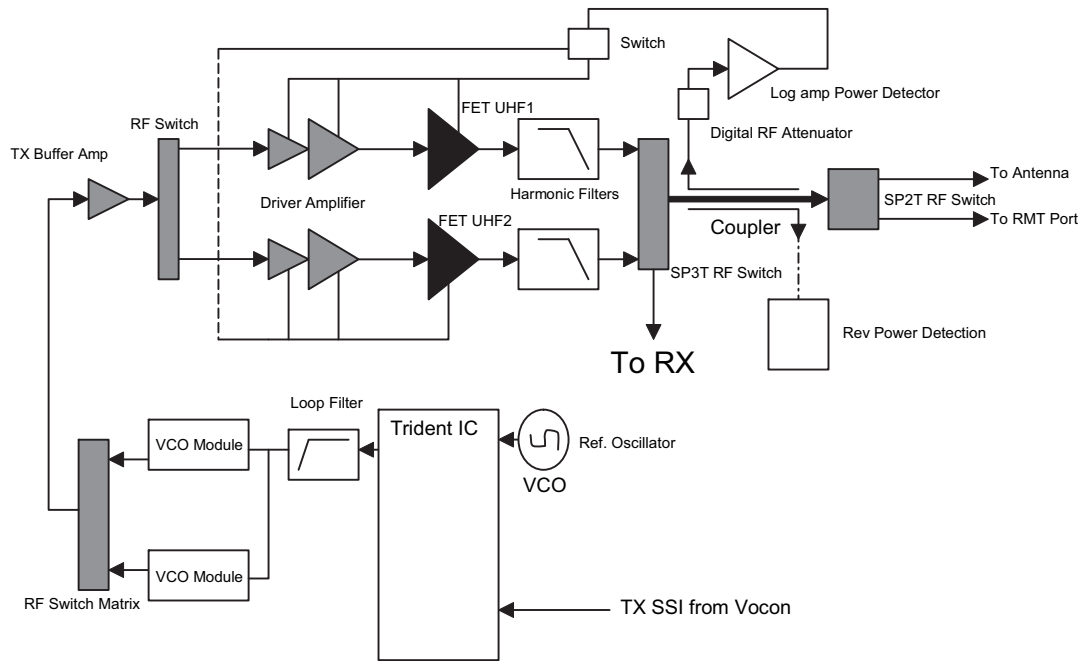

Figure 3-12. Transceiver (UHF1 and UHF2) Block Diagram

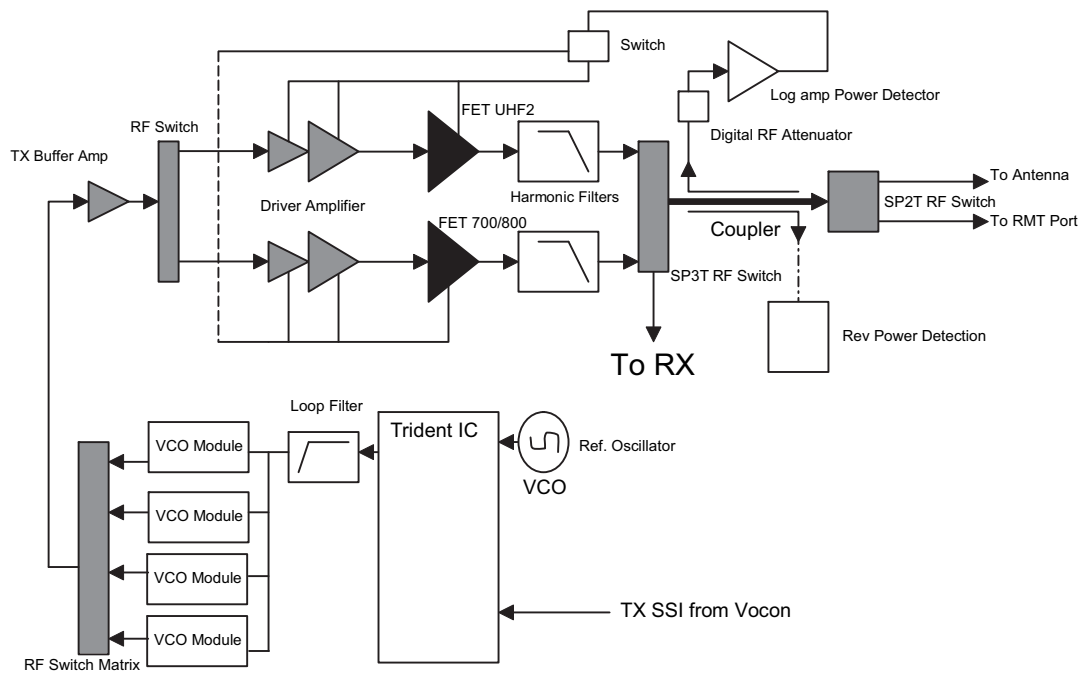

Figure 3-13. Transceiver (UHF2 and 700–800 MHz) Block Diagram

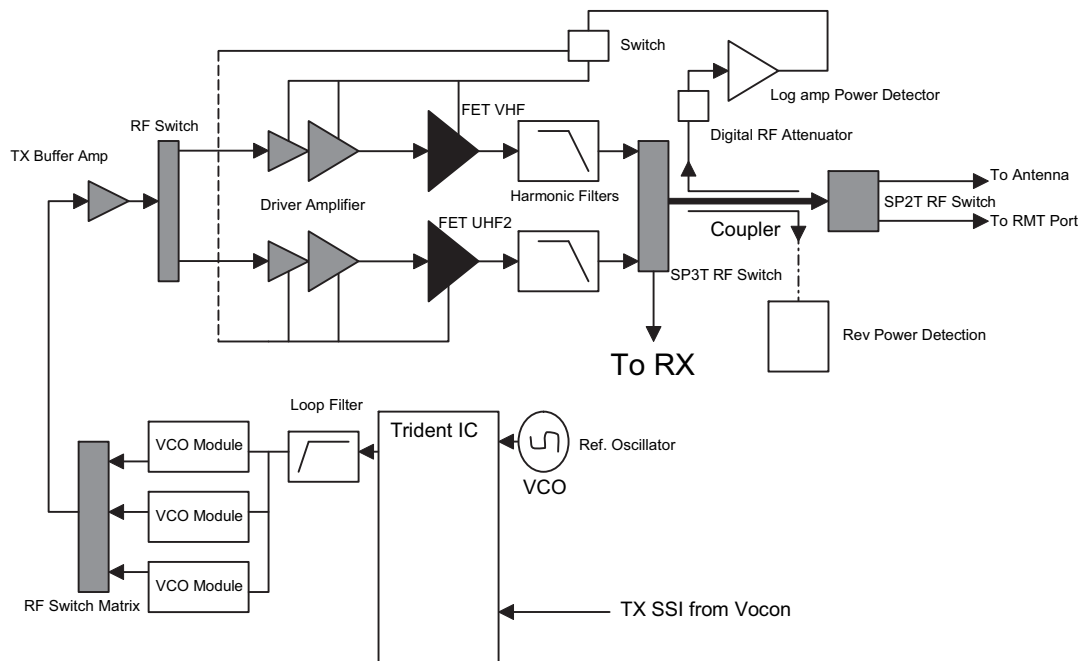

Figure 3-14. Transceiver (VHF and UHF2) Block Diagram

### 3.2.2.1 VHF Transmit

Once a VHF frequency for transmit has been selected, the Trident IC and its accompanying logic circuitry enable the correct voltage controlled oscillator which then generates the desired transmit frequency. This transmit signal is then routed to the TX buffer amplifier which amplifies the signal. An RF switch then routes the signal to the VHF Driver amplifier and then to the discrete final stage. The signal is then filtered by a harmonic filter and passed through a RF switch into a directional coupler. The Log Amp power detector monitors the output of the directional coupler and adjusts the control voltages to the driver amplifier and the discrete final. Finally, the RF signal comes to a Single Pole Double Throw (SP2T) RF switch which can route the power to the main antenna or to the Universal Connector port of the radio.

### 3.2.2.2 700/800 MHz Transmit

Once a 700/800 MHz frequency for transmit has been selected, the Trident IC and its accompanying logic circuitry enable the correct voltage controlled oscillator which then generates the desired transmit frequency. This transmit signal is then routed to the TX buffer amplifier which amplifies the signal. An RF switch then routes the signal to the 700/800 MHz Driver amplifier and then to the discrete final stage. The signal is then filtered by a harmonic filter and passed through a RF switch into a directional coupler. The Log Amp power detector monitors the output of the directional coupler and adjusts the control voltages to the driver amplifier and the discrete final. Finally, the RF signal comes to a Single Pole Double Throw (SP2T) RF switch which can route the power to the main antenna or to the Universal Connector port of the radio.



### 3.2.2.3 UHF1 Transmit

Once a UHF frequency for transmit has been selected, the Trident IC and its accompanying logic circuitry enable the correct voltage controlled oscillator which then generates the desired transmit frequency. This transmit signal is then routed to the TX buffer amplifier which amplifies the signal. An RF switch then routes the signal to the UHF1 Driver amplifier and then to the discrete final stage. The signal is then filtered by a harmonic filter and passed through a RF switch into a directional coupler. The Log Amp power detector monitors the output of the directional coupler and adjusts the control voltages to the driver amplifier and the discrete final. Finally, the RF signal comes to a Single Pole Double Throw (SP2T) RF switch which can route the power to the main antenna or to the Universal Connector port of the radio.

### 3.2.2.4 UHF2 Transmit

Once a UHF frequency for transmit has been selected, the Trident IC and its accompanying logic circuitry enable the correct voltage controlled oscillator which then generates the desired transmit frequency. This transmit signal is then routed to the TX buffer amplifier which amplifies the signal. An RF switch then routes the signal to the UHF2 Driver amplifier and then to the discrete final stage. The signal is then filtered by a harmonic filter and passed through a RF switch into a directional coupler. The Log Amp power detector monitors the output of the directional coupler and adjusts the control voltages to the driver amplifier and the discrete final. Finally, the RF signal comes to a Single Pole Double Throw (SP2T) RF switch which can route the power to the main antenna or to the Universal Connector port of the radio.

## 3.3 Digital (ASTRO) Mode of Operation

In the ASTRO (digital) mode of operation, the transmitted or received signal is limited to a discrete set of frequency deviation levels. The receiver handles an ASTRO-mode signal identically to an analog-mode signal, up to the point where the DSP decodes the received data. In the ASTRO receive mode, the DSP uses a different algorithm to recover data.

In the ASTRO transmit mode, microphone audio is processed identically to an analog mode, with the exception of the algorithm the DSP uses to encode the information. Using this algorithm, transmitter FM deviation is limited to discrete levels.

### 3.4 Controller Section

The controller section (see Figure 3-15) comprises of five functional sections that are split among three boards, which are the VOCON, EXPANSION and BLUETHOOTH OPTION boards. The main functional section consists of a dual core ARM and DSP controller, an encryption processor (MACE), Flash memory, and a Double Data Rate Synchronous Dynamic Random Access Memory (DDR SDRAM). The Power and Clocks section includes a power management IC (MAKO) and various external switching regulators, and two clock sources (12 MHz and 24.576 MHz) from which all other controller digital clocks are derived. The Audio section has a CODEC and a class-D audio power amplifier that provides the radio with a multiple microphone, multiple speaker design. The User Interface section provides communication and control to the top and main Liquid Crystal Displays (LCD) on the radio, as well as a keypad and a side connector interface conforming to Universal Connector specifications. The Expansion Memory, GPS and Bluetooth section comprises of a Micro SD memory interface, Global Positioning Satellite (GPS) processor, and an Option Board for radio feature upgrades.

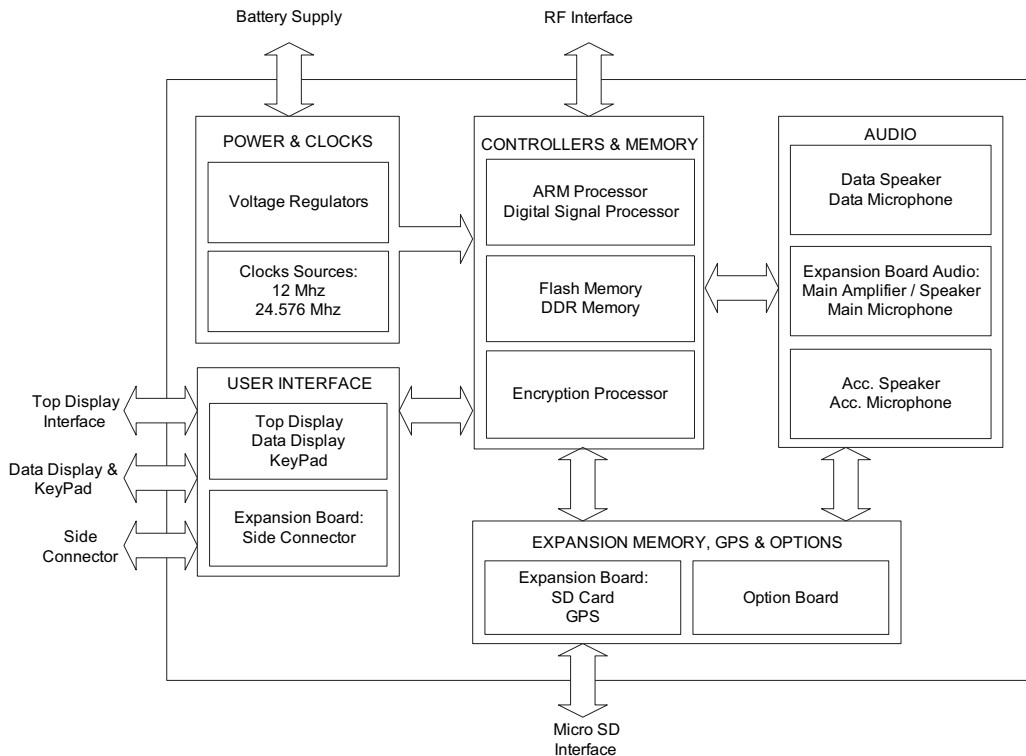

Figure 3-15. Controller Block Diagram

The ARM controller core of the OMAP processor handles the power up sequence of all devices, including firmware upgrades, and all operating system tasks that are associated with FLASH and SDRAM memories and user interface communication. The FLASH memory (64 MB) is required to store the firmware, tuning, and Codeplug settings, which upon initialization get read and stored into SDRAM (32 MB) for execution. The ARM and DSP core jointly control and configure audio, wireless and RF devices linked to the Serial Peripheral Interface (SPI) and Synchronous Serial Interface (SSI) buses to enable radio FM and optional wireless communication protocols. For encryption, a separate ARM processor is used (MACE) to encode and decode encryption packets coming in from the main OMAP processor through the SSI interface. Its firmware is flashed via the main processor during an upgrade request to its internal FLASH memory.

The power and most clocks to the controller devices are provided by the MAKO IC and external switching and linear regulators on board. A Complex Programmable Logic Array (CPLD) IC divides the 24.576 MHz clock from MAKO to source OMAP's 32 kHz Real Time Clock, and MACE's 4 MHz main clock. OMAP's main clock is supplied externally from an on board 12 MHz crystal.

The radio has two internal microphones and two internal speakers, as well as available microphone and speaker connections for external accessories. The main external speaker is located opposite to the main display and keypad of the radio. It can deliver a rated power of 1W on a ~4 Ohms speaker, while the smaller "data" speaker can only deliver 0.5 W of power on a load of 16 Ohms. Both internal and external microphones use the CODEC's AD to deliver digital audio samples to the DSP controller. The main speaker is driven by the class D PA on the expansion board, while the data and external speakers are driven by the AB type PA on MAKO. Both speaker paths use the CODEC for volume control and to convert audio from digital to analog.

The user interface block consists of a top and main or "data side" display, a keypad, top controls and the accessory side connector. The side connector (Universal Connector) provides audio, USB, RS232 and RF communication for accessories. All signals to and from the connector go through the internal expansion board before reaching the microcontroller and other devices on the main board.

The radio also has an expansion bay for a Micro SD memory card, a Global Positioning System (GPS) interface, and an bluetooth slot for radio feature upgrades. The memory card can be inserted on the bay near the battery connector of the radio. The bluetooth slot of the radio is available internally to the radio, and it is not hot swappable by the user. The bluetooth slot is available through a connector directly linked to the main controller board.

## Notes

# Chapter 4 Recommended Test Equipment and Service Aids

This chapter provides lists of recommended test equipment and service aids, as well as information on field programming equipment that can be used in servicing and programming ASTRO APX 7000XE radios.

## 4.1 Recommended Test Equipment

The list of equipment contained in [Table 4-1](#) includes all of the standard test equipment required for servicing two-way portable radios, as well as several unique items designed specifically for servicing this family of radios. The “Characteristics” column is included so that equivalent equipment may be substituted; however, when no information is provided in this column, the specific Motorola model listed is either a unique item or no substitution is recommended.

*Table 4-1. Recommended Test Equipment*

Equipment	Characteristics	Example	Application
Service Monitor	Can be used as a substitute for items marked with an asterisk (*)	Aeroflex 3920 ( <a href="http://www.aeroflex.com">www.aeroflex.com</a> ) or R-2670 Communication Analyzer, 8901_ Modulation Analyzer ( <a href="http://www.agilent.com">www.agilent.com</a> ) or equivalent	Frequency/deviation meter and signal generator for wide-range troubleshooting and alignment
Digital RMS Multimeter *	100 $\mu$ V to 300 V 5 Hz to 1 MHz 10 Mega Ohm Impedance	Fluke 179 or equivalent ( <a href="http://www.fluke.com">www.fluke.com</a> )	AC/DC voltage and current measurements. Audio voltage measurements
RF Signal Generator *	100 MHz to 1 GHz -130 dBm to +10 dBm FM Modulation 0 kHz to 10 kHz Audio Frequency 100 Hz to 10 kHz	Agilent N5181A ( <a href="http://www.agilent.com">www.agilent.com</a> ), Ramsey RSG1000B ( <a href="http://www.ramseyelectronics.com">www.ramseyelectronics.com</a> ), or equivalent	Receiver measurements
Oscilloscope *	2 Channel 50 MHz Bandwidth 5 mV/div to 20 V/div	Leader LS8050 ( <a href="http://www.leaderusa.com">www.leaderusa.com</a> ), Tektronix TDS1001b ( <a href="http://www.tektronix.com">www.tektronix.com</a> ), or equivalent	Waveform measurements
RF Millivolt Meter	100 mV to 3 V RF 10 kHz to 1 GHz	Boonton 9240 ( <a href="http://www.boonton.com">www.boonton.com</a> ) or equivalent	Waveform measurements
Power Supply	0 V to 32 V 0 A to 20 A	B&K Precision 1790 ( <a href="http://www.bkprecision.com">www.bkprecision.com</a> ) or equivalent	Voltage supply

## 4.2 Service Aids

Refer to [Table 4-2](#) for a listing and description of the service aids designed specifically for servicing this family of radios. These kits and/or parts are available from the Radio Products and Solutions Organization offices listed in [“Appendix B. Replacement Parts Ordering”](#) on page B-1. While all of these items are available from Motorola, most are standard shop equipment items, and any equivalent item capable of the same performance may be substituted for the item listed.

Table 4-2. Service Aids

Motorola Part Number	Description	Application
1110027B23	Speaker Module Seal Lubricant	Used to ensure good sealing of the Speaker Module to the Main Chassis.
5880384G68	SMA to BNC Adapter	Adapts radio's antenna port to BNC cabling of test equipment.
66009254001	APX 7000/ APX 7000XE Battery Eliminator	Used in place of battery to connect radio to an external power supply.
66009275001	Grille Eliminator	Special tool used when pressure testing the radio. Replaces the radio grille to seal the port vent.
66009256001	Volume Potentiometer Outer Spanner Bit	Used to assemble and disassemble the spanner nut on the volume potentiometer.
66009258001	Antenna Spanner Bit	Used to assemble and disassemble the spanner nut on the antenna bushing.
66009259001	Vacuum Adapter	Submersible radios only. Connects the vacuum/pressure hose to the radio.
66009260001	Board Analysis Fixture (APX 7000)	Special fixture that allows radio's internal board to be mounted externally. Provides easy access to electronic circuits, required for board-level troubleshooting.  <b>NOTE:</b> Contact Motorola Solutions Radio Products and Solutions Organization (1-800-927-2744) to determine which version of fixture is required for your APX 7000XE radio.
66009260003	Board Analysis Fixture (APX 7000XE and future APX 7000)	
NLN9839_	Vacuum Pump Kit	Submersible radios only. Vacuum pump with gauge and vacuum hose. Requires 66009259001 Adapter Kit.
NTN4265_	Pressure Pump Kit	Submersible radios only. Pressure pump with gauge and pressure hose. Requires 66009259001 Adapter Kit.
RVN5224_	Customer Programming Software (CPS) and Tuner Software	CPS allows customer-specific programming of modes and features. Tuner software required to perform alignment of radio parameters.
PMKN4012_	Programming Cable	Used to program the radio through Customer Programming Software and Tuner Software.
PMKN4013_	Programming/Service Cable	Used to program and service the radio through Customer Programming Software and Tuner Software.
RLN4460_	Portable Test Set	Used for radio performance checks. Connects to radio's universal connector and allows remote switching and signal injection/outputs for test equipment measurements.

## **4.3 Field Programming**

This family of radios can be aligned and programmed in the field. This requires specific equipment and special instructions. Refer to the online help in the Customer Programming Software (CPS) for complete field programming information.

## Notes



# Chapter 5 Performance Checks

This chapter covers performance checks used to ensure that the ASTRO APX 7000XE radio meets published specifications. The recommended test equipment listed in the previous section approaches the accuracy of the manufacturing equipment, with a few exceptions. Accuracy of the test equipment must be maintained in compliance with the manufacturer's recommended calibration schedule. Checks should be performed if radio performance degradation is suspected.

## 5.1 Test Equipment Setup

Supply voltage can be connected from the battery eliminator. The equipment required for the performance checks is connected as shown in [Figure 5-1](#).

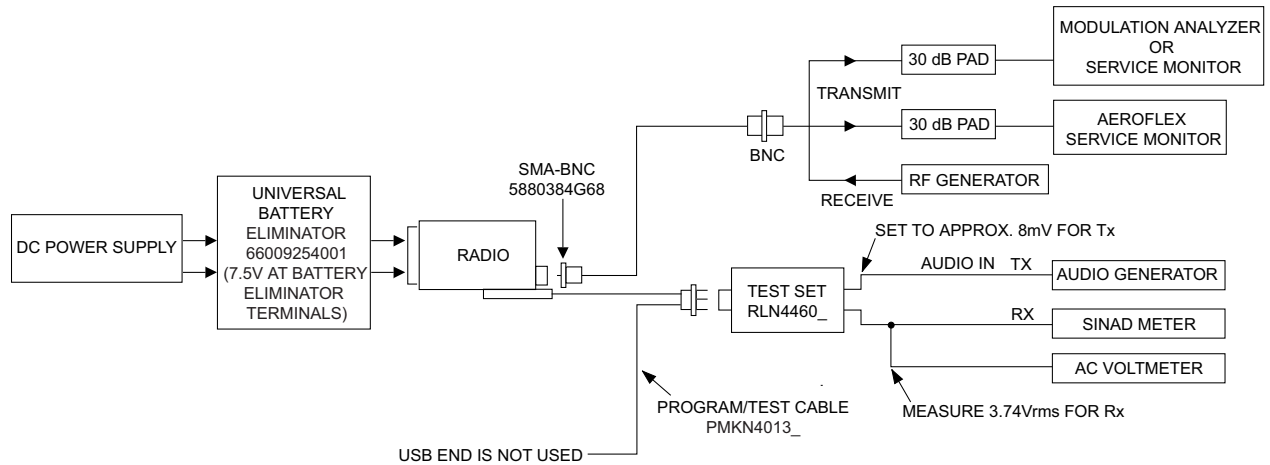

Figure 5-1. Performance Checks Test Setup

Initial equipment control settings should be as indicated in [Table 5-1](#) and should be the same for all performance checks and alignment procedures, except as noted.

Table 5-1. Initial Equipment Control Settings

System Analyzer	Test Set	Power Supply
<b>Monitor Mode:</b> Standard*	<b>Spkr/Load:</b> Speaker	<b>Voltage:</b> 7.5 Vdc
Receiver Checks <b>RF Control:</b> GEN <b>Output Level:</b> -47 dBm <b>Modulation:</b> 1 kHz tone @3 kHz deviation for 25 kHz channel spacing @1.5 kHz deviation for 12.5 kHz channel spacing <b>Frequency:</b> Set to selected radio RX frequency <b>Meter:</b> AC Volts  Transmitter Checks <b>RF Control:</b> MONITOR <b>Frequency:</b> Set to selected radio TX frequency <b>Meter:</b> RF Display <b>Modulation Type:</b> FM <b>Attenuation:</b> 20 dB	<b>PTT:</b> OFF (center)	<b>DC On/Standby:</b> Standby
	<b>Meter Out:</b> RX	<b>Volt Range:</b> 10 Vdc
	<b>Opt Sel:</b> ON	<b>Current:</b> 2.5 Amps

\* Use "PROJ 25 STD" if testing ASTRO Conventional channels.

## 5.2 Display Radio Test Mode (Dual-Display Version)

This section provides instructions for performing tests in display radio test mode.

### 5.2.1 Access the Test Mode

To enter the display radio test mode:

1. Turn the radio on.
2. Within 10 seconds after “SELF TEST” is complete, press **Side Button 2** five times in succession.

The radio shows a series of displays that give information regarding various version numbers and subscriber specific information. The displays are described in [Table 5-2](#).

*Table 5-2. Test-Mode Displays*

Name of Display	Description	Appears
<b>Service</b>	The literal string indicates the radio has entered test mode.	Always
<b>Host version</b>	The version of host firmware is displayed.	Always
<b>DSP version</b>	The version of DSP firmware is displayed.	Always
<b>Secure version</b>	Version of the encryption software	When the radio is secure equipped
<b>KG1</b> algorithms name (Encryption Type 1)	Type of encryption being used	When the radio is secure equipped
<b>KG2</b> algorithms name (Encryption Type 2)	Type of encryption being used	When the radio is secure equipped and 2 or more algorithms are loaded
<b>KG3</b> algorithms name (Encryption Type 3)	Type of encryption being used	When the radio is secure equipped and 3 or more algorithms are loaded
<b>KG4</b> algorithms name (Encryption Type 4)	Type of encryption being used	When the radio is secure equipped and 4 or more algorithms are loaded
<b>KG5</b> algorithms name (Encryption Type 5)	Type of encryption being used	When the radio is secure equipped and 5 or more algorithms are loaded
<b>Model number</b>	The radio’s model number, as programmed in the codeplug	Always
<b>Serial number</b>	The radio’s serial number, as programmed in the codeplug	Always
<b>ESN</b>	The radio’s unique electronic serial number	Always
<b>ROM Size</b>	The memory capacity of the host FLASH part	Always

Table 5-2. Test-Mode Displays (Continued)

Name of Display	Description	Appears
FLASHcode	The FLASH codes as programmed in the codeplug	Always
RF band 1	The radio's operating frequency	Always
RF band 2	The radio's operating frequency	When the radio has more than 1 operating frequency
Tuning ver	Version of Tuning codeplug	Always
Proc ver	Version of Processor	Always
Option Board Type	Type of Option Board in the radio	When the radio is equipped with an Option Board
Option Board Bluetooth Addr	Address of the Bluetooth IC	When the radio is equipped with a Bluetooth Option Board
Option Board SW Version	Version of Option Board software	When the radio is equipped with an Option Board

**NOTE:** All displays are temporary and will expire without any user intervention. If information is longer than the physical length of the radio's display, the information will wrap around to the next display. After the last display, "RF TEST" is displayed.

To freeze any of the displays, press the left arrow on the 4-Way Navigation Button. To resume automatic scrolling, press the right arrow on the 4-Way Navigation Button. To rapidly scroll forward through the displays, continue pressing the right arrow. You cannot scroll backwards.

**NOTE:** Press the Top side (purple) button to advance the test environments from "RF TEST", "CH TEST", "RGB TEST", "CID TEST" then press the orange button to confirm selection. Press any other buttons to advance the test.

Once a test is carried out, restart the radio to proceed to another test.

3. Do one of the following:

- Press the **Top Side Button** to stop the displays and toggle between RF test mode and the Control Top and Keypad test mode. The test mode menu "CH TEST" is displayed, indicating that you have selected the Control Top and Keypad test mode. Go to Section "5.2.3 Control Top and Keypad Test Mode" on page 2:5-6.

**NOTE:** Each press of the **Top Side Button** will toggle between "CH TEST" and "RF TEST".

- Press the **Top Button** (Orange button) to stop the displays and put the radio into the RF test mode. The test mode menu, "1 CSQ", is displayed, indicating test frequency 1, Carrier Squelch mode. Go to Section "5.2.2 RF Test Mode" below.

**NOTE:** Once your radio is in a particular test mode, you must turn off the radio and turn it back on again to access the other test mode.

## 5.2.2 RF Test Mode

When the ASTRO APX 7000XE radio is operating in its normal environment, the radio's microcomputer controls the RF channel selection, transmitter key-up, and receiver muting, according to the customer codeplug configuration. However, when the unit is on the bench for testing, alignment, or repair, it must be removed from its normal environment using a special routine, called **RF TEST MODE**.

While in RF test mode:

- Each additional press of **Side Button 2** advances to the next test channel. (Refer to [Table 5-3](#).)
- Pressing **Side Button 1** scrolls through and accesses the test environments shown in [Table 5-4](#).

**NOTE:** Transmit into a load when keying a radio under test.

Table 5-3. Test Frequencies (MHz)

Test Channel	VHF		UHF1		UHF2		700–800 MHz	
	RX	TX	RX	TX	RX	TX	RX	TX
F1	136.075	136.025	380.075	380.025	450.075	450.025	764.0625	764.0125
F2	142.075	142.125	390.075	390.025	460.075	460.025	769.0625	769.0125
F3	154.275	154.225	400.075	400.025	471.075	471.025	775.9375	775.9875
F4	160.175	160.125	411.075	411.025	484.925	484.975	851.0625	794.0125
F5	168.125	168.075	424.975	424.925	485.075	485.025	860.0625	809.0125
F6	173.925	173.975	435.075	435.025	495.075	495.025	869.9375	823.9875
F7	–	–	444.925 (Tune) / 445.075 (Test Mode)	444.975 (Tune) / 444.999995 (Test Mode)	506.075	506.025	851.0625	851.0125
F8	–	–	445.075	445.025 (Tune) / 445.000005 (Test Mode)	519.925	519.975	860.0625	860.0125
F9	–	–	457.075	457.025	–	–	869.9375	869.8875
F10	–	–	469.975	469.925	–	–	–	–

Table 5-4. Test Environments

Display	Description	Function
<b>CSQ</b>	Carrier Squelch	RX: unsquelch if carrier detected TX: mic audio
<b>TPL</b>	Tone Private-Line	RX: unsquelch if carrier and tone (192.8 Hz) detected TX: mic audio + tone (192.8 Hz)
<b>SEC</b>	Secure**	RX: auto-coded clear TX: with key present–encrypted audio with key absent–constant unsquelch

Table 5-4. Test Environments (Continued)

Display	Description	Function
AST	ASTRO	RX: none TX: Digital Voice***
USQ	Carrier Unsquench	RX: unsquelch always TX: mic audio

\*\* On radios equipped with secure option.

\*\*\*All deviation values are based on deviation tuning of this mode.

### 5.2.3 Control Top and Keypad Test Mode

This test mode is used to verify proper operation of all radio buttons and switches if a failure is suspected.

#### 5.2.3.1 Control Top Checks







To perform the control top checks:

1. Press and hold the **Top Button** (Orange button); the radio icons are displayed, and the LED lights amber.
2. Release the **Top Button**; "148/0" appears, which indicates that the **Top Button** is in the open position. Your radio is now in the Control Top and Keypad test mode.
3. Press the **Top Button** again; "148/1" appears, which indicates that the **Top Button** is in the closed position.
4. Rotate the **16-Position Select Switch**; "4/0" through "4/15" appears, which indicates that the selector switch is in mode/zone position 1 through 16.
5. Rotate the **Two-Position Concentric Switch**; "65/0" and "65/1" appear.
6. Cycle through the **Three-Position A/B/C Switch**; "67/0," "67/1," and "67/2" appear.
7. Rotate the **Volume Control**; "2/0" through "2/255" appear. The display values may vary slightly at the upper and lower limits.
8. Press the **Top Side Button**; "96/1" appears; release, "96/0" appears.
9. Press **Side Button 1**; "97/1" appears; release, "97/0" appears.
10. Press **Side Button 2**; "98/1" appears; release, "98/0" appears.
11. Press the **PTT Button**; "1/1" appears; release, "1/0" appears.

#### 5.2.3.2 Keypad Checks:

To continue to the keypad checks:

##### 5.2.3.2.1 Dual-Display Model

- Press , "48/1" appears; release, "48/0" appears.
- Press , "49/1" appears; release, "49/0" appears.
- Press , "50/1" appears; release, "50/0" appears.
- Press , "51/1" appears; release, "51/0" appears.
- Press , "52/1" appears; release, "52/0" appears.
- Press , "53/1" appears; release, "53/0" appears.

- Press , "54/1" appears; release, "54/0" appears.
- Press , "55/1" appears; release, "55/0" appears.
- Press , "56/1" appears; release, "56/0" appears.
- Press , "57/1" appears; release, "57/0" appears.
- Press , "58/1" appears; release, "58/0" appears.
- Press , "59/1" appears; release, "59/0" appears.
- Press , "128/1" appears; release, "128/0" appears.
- Press , "129/1" appears; release, "129/0" appears.
- Press , "130/1" appears; release, "130/0" appears.
- Press , "131/1" appears; release, "131/0" appears.
- Press , "132/1" appears; release, "132/0" appears.
- Press , "133/1" appears; release, "133/0" appears.
- Press , "134/1" appears; release, "134/0" appears.
- Press , "135/1" appears; release, "135/0" appears.
- Press , "136/1" appears; release, "136/0" appears.

## 5.3 Top-Display Version Radio Test Mode

This section provides instructions for performing tests in non-display radio test mode.

### 5.3.1 Access the Test Mode

To enter the non-display radio test mode:

1. Turn the radio on.
2. Within 10 seconds after the top red LED turns off, press **Side button 2** five times in succession.
3. Do one of the following:
  - Press the **Top Side Button** to put the radio into the Control Top and Keypad test mode. Go to ["5.3.3 Control Top Test Mode"](#) below.

**NOTE:** Each press of the **Top Side Button** toggles between Control Top and Keypad test mode (non-display radio) and RF test mode (non-display radio).

- Press the **Top Button** (Orange button) to put the radio into the RF test mode. Go to ["5.3.2 RF Test Mode"](#) below.

### 5.3.2 RF Test Mode

When the ASTRO APX 7000XE radio is operating in its normal environment, the radio's microcomputer controls the RF channel selection, transmitter key-up, and receiver muting, according to the customer codeplug configuration. However, when the unit is on the bench for testing, alignment, or repair, it must be removed from its normal environment via a special routine, called **RF TEST MODE**.

While in RF test mode:

- Each additional press of **Side Button 2** advances to the next test channel. (Refer to [Table 5-3 on page 2:5-5](#)) The channel number is represented by the number of tones emitted by the radio after the button press (for example, five tones indicates channel 5).

- Pressing **Side Button 1** scrolls through and accesses test environments shown in [Table 5-4 on page 2:5-5](#). The test environment is represented by the number of tones emitted by the radio after the button press (for example, 11 tones indicate AST).

### 5.3.3 Control Top Test Mode

This test mode is used to verify proper operation of all radio buttons and switches if a failure is suspected.

To perform the control top checks:

1. Press and hold the **Top Button** (Orange button); the LED lights red, and the radio beeps.
2. Release the **Top Button**; the radio beeps, indicating that the **Top Button** is in the open position.
3. Press the **Top Button** again; the radio beeps, indicating that the **Top Button** is in the closed position.
4. Rotate the **Two-Position Concentric Switch**; the radio beeps in each switch position.
5. Rotate the **16-Position Select Switch**; the radio beeps in each switch position.
6. Cycle through the **Three-Position A/B/C Switch**; the radio beeps in each switch position.
7. Rotate the **Volume Control**; the radio beeps at each new volume setting.
8. Press the **Top Side Button**; the radio beeps.
9. Press **Side Button 1**; the radio beeps.
10. Press **Side Button 2**; the radio beeps.



## 5.4 Receiver Performance Checks

The following tables outline the performance checks for the receiver.

Table 5-5. Receiver Performance Checks

Test Name	System Analyzer	Radio	Test Set	Comments
Rated Audio	<b>RF Control:</b> Gen <b>Output Level:</b> -47 dBm <b>Freq:</b> Selected radio RX freq. <b>Mod:</b> 1 kHz tone @ 3 kHz dev. <b>Meter:</b> AC Volts	As above	<b>PTT</b> to OFF (center)	Set volume control to 3.74 Vrms
Distortion	As above, except <b>Meter:</b> Ext Dist.	As above	As above	Distortion < 3.0%
Sensitivity (SINAD)	As above, except <b>Meter:</b> SINAD	As above	As above	RF input to be < 0.35 $\mu$ V
Noise Squelch Threshold (only radios with conventional system need to be tested)	Set as for rated audio check	Out of TEST MODE; select a conventional system	As above	Set volume control to 3.74 Vrms. Set RF level to -130 dBm and raise until radio unsquelches. Unsquelch to occur at < 0.25 $\mu$ V. Preferred SINAD = 6–8 dB.

\* See Table 5-4 on page 2:5-5.

Table 5-6. Receiver Tests for ASTRO Conventional Channels\*

Test Name	System Analyzer	Radio	Test Set	Comments
Bit Error rate (BER) Floor	<b>Mode:</b> Proj 25 Std <b>RF Control:</b> Gen <b>Output Level:</b> -47 dBm <b>Proj 25 Dev:</b> 2.83 kHz <b>Code:</b> 1011 Hz PAT	Radio Tuner Software (Bit Error Rate screen) is required	<b>PTT</b> to OFF (center)	BER < 0.01% (Use test setup shown in <a href="#">Figure 6-1 on page 2:6-1</a> )
Reference Sensitivity	As above; lower the output level until 5% BER is obtained	As above	As above	Output level < 0.35 $\mu$ V (-116 dBm) (Use test setup shown in <a href="#">Figure 6-1 on page 2:6-1</a> )
Audio Output Distortion	<b>Mode:</b> Proj 25 Std <b>RF Control:</b> Gen <b>Output Level:</b> -47 dBm <b>Proj 25 Dev:</b> 2.83 kHz <b>Code:</b> 1011 Hz PAT <b>Meter:</b> Ext. Distortion	Radio Tuner Software not used; <b>Radio:</b> Out of TEST MODE; Select a conventional ASTRO channel	<b>PTT</b> to OFF (center) Meter selector to <b>Audio PA Spkr/Load to Speaker</b>	Distortion < 3.0%

Table 5-6. Receiver Tests for ASTRO Conventional Channels\* (Continued)

Test Name	System Analyzer	Radio	Test Set	Comments
Residual Audio Noise Ratio	<b>Mode:</b> Proj 25 Std <b>RF Control:</b> Gen <b>Output Level:</b> -47 dBm <b>Proj 25 Dev:</b> 2.83 kHz <b>Code:</b> A) 1011 Hz PAT B) Silence PAT <b>Meter:</b> AC Volts	As above	As above	Residual Audio Noise Ratio -45 dB

\* These tests require a communications system analyzer with the ASTRO 25 test options.

## 5.5 Transmitter Performance Checks

The following tables outline the performance checks for the transmitter.

Table 5-7. Transmitter Performance Checks

Test Name	System Analyzer	Radio	Test Set	Comments
Reference Frequency	<b>RF Control:</b> Monitor <b>Meter:</b> RF Display <b>Display:</b> Bar Graphs <b>Freq:</b> Selected radio TX freq.	TEST MODE CSQ channel* or programmed conventional channel	<b>PTT</b> to continuous (during the performance check).	<b>VHF:</b> 2.0 ppm (272–348 Hz) <b>700/800 MHz:</b> 1.5 ppm (1.15–1.3 kHz) <b>UHF1:</b> 2 ppm (760–940 Hz) <b>UHF2:</b> 2 ppm (900–1040 Hz)
RF Power	As above	As above	As above	<b>VHF:</b> 1–6 Watts <b>700/800 MHz:</b> <b>764–806 MHz:</b> 2.5 Watts <b>806–870 MHz:</b> 3 Watts <b>UHF1:</b> 1–5 Watts <b>UHF2:</b> 1–5 Watts
Voice Modulation (external)	As above. Set fixed 1 kHz audio level to approximately 10 mV.	As above	As above	Deviation: (12.5 kHz) ≥ 2.1 kHz, but ≤ 2.5 kHz (25 kHz) ≥ 4.1 kHz, but ≤ 5.0 kHz
Voice Modulation (internal)	For Modulation Analyzer: FM measurements 15 kHz LP Filter	As above	Remove modulation input. <b>PTT</b> to OFF (center)	Press <b>PTT</b> button on radio. Say “four” loudly into the radio mic. Measure deviation: (12.5 kHz) ≥ 2.1 kHz but ≤ 2.5 kHz (25 kHz) ≥ 4.1 kHz but ≤ 5.0 kHz

Table 5-7. Transmitter Performance Checks (Continued)

Test Name	System Analyzer	Radio	Test Set	Comments
PL Modulation (radios with conventional, clear mode, coded squelch operation only)	For Modulation Analyzer: FM measurements 15 kHz LP Filter	Conventional coded squelch personality TPL channel (test mode*)	<b>PTT</b> to continuous (during the performance check)	Deviation: (12.5 kHz) $\geq 375$ Hz but $\leq 500$ Hz (25 kHz) $\geq 500$ Hz but $\leq 1000$ Hz
Secure Modulation (radios with conventional, secure mode, talkaround operation only)	As above	Programmed conventional channel (secure mode operation) Load key into radio.	As above	Deviation: $\geq 3.7$ kHz but $\leq 4.3$ kHz

\* See [Table 5-5 on page 2:5-9](#).

Table 5-8. Transmitter Tests for ASTRO Conventional Channels\*

Test Name	System Analyzer	Radio	Test Set	Comments
RF Power	Aeroflex or equivalent Service Monitor	Select a Conventional Channel	<b>PTT</b> to continuous (during measurement).	<b>VHF:</b> 1–6 Watts <b>700/800 MHz:</b> <b>764–806 MHz:</b> 2.5 Watts <b>806–870 MHz:</b> 3 Watts <b>UHF1:</b> 1–5 Watts <b>UHF2:</b> 1–5 Watts
Frequency Error	As above	As above	As above	Error $\leq \pm 1.0$ kHz
Frequency Deviation	As above	Radio Tuner Software (Transmitter Test Pattern screen) is required) <b>High use:</b> Symbol Rate PAT <b>Low use:</b> Low Symbol Rate P	<b>PTT</b> to OFF (center)	$D_{HIGH}$ $\geq 2.543$ kHz but $\leq 3.110$ kHz $D_{LOW}$ $\geq 0.841$ kHz but $\leq 1.037$ kHz (Use test setup shown in <a href="#">Figure 6-1 on page 2:6-1</a> )

\* These tests require a communications system analyzer with the ASTRO 25 test options.

## Notes

# Chapter 6 Radio Alignment Procedures

This chapter describes both receiver and transmitter radio alignment procedures.

## 6.1 Test Setup

A personal computer (PC) and tuner software are required to align the radio. Refer to the applicable manual for installation and setup procedures for the software. To perform the alignment procedures, the radio must be connected to the PC and to a universal test set. The radio alignment test setup is shown in [Figure 6-1](#).

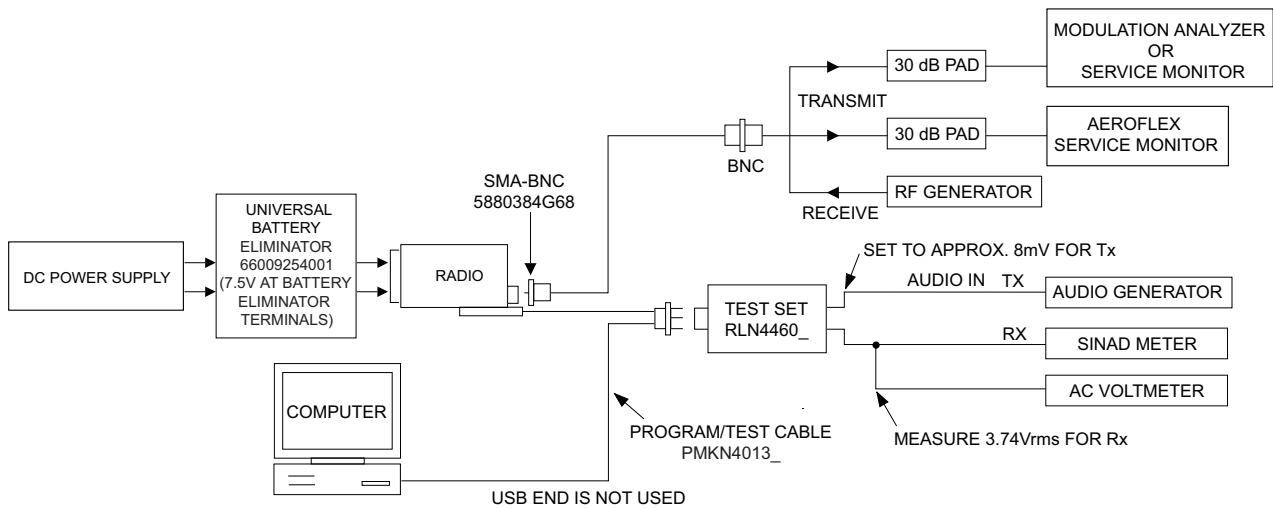



Figure 6-1. Radio Alignment Test Setup



Caution

These radio alignment procedures should only be attempted by qualified service personnel. Failure to perform alignment procedures properly may result in seriously degraded radio or system performance.

## 6.2 Tuner Main Menu

Select **Tuner** from the **START** menu by clicking **Start > Program Files > Motorola > ASTRO 25 Products > ASTRO 25 Tuner**. To read the radio, use the **File > Read Device** menu or click on . [Figure 6-2](#) illustrates how the alignment screens are organized. To access a screen, double-click on the desired screen name in the **Tuner** menu.

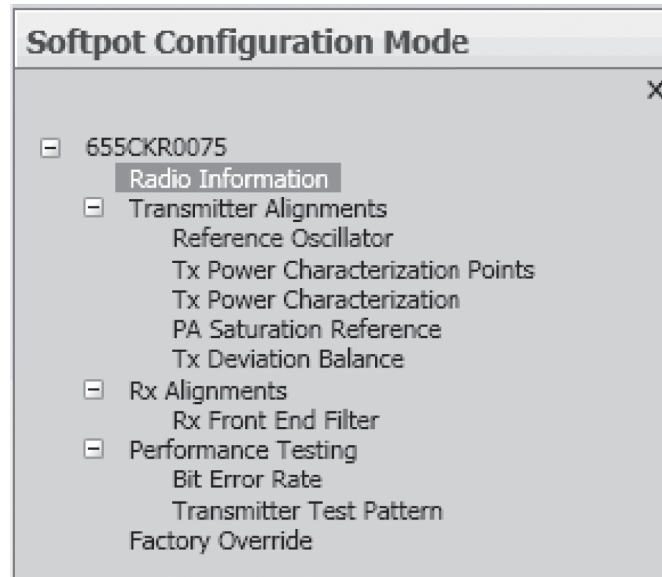

*Figure 6-2. Tuner Software Main Menu*

**IMPORTANT:** Tuning should follow the order of the Tuning tree view in descending order from top to bottom

## 6.3 Softpot

The alignment screens introduce the concept of the “softpot,” an analog **SOFTWARE**-controlled **POT**entiometer used for adjusting all transceiver alignment controls.

 Caution	<p>DO NOT switch radios in the middle of any alignment procedure. Always left-click the <b>Close</b> button on the screen to return to the Main Menu screen before disconnecting the radio. Improper exits from the alignment screens might leave the radio in an improperly configured state and result in seriously degraded radio or system performance.</p>
--	---

Each alignment screen provides the ability to increase or decrease the softpot value by using a slider, or by entering the new value from the keyboard directly into the box. The slider bar indicates the current softpot value; see [Figure 6-3](#).

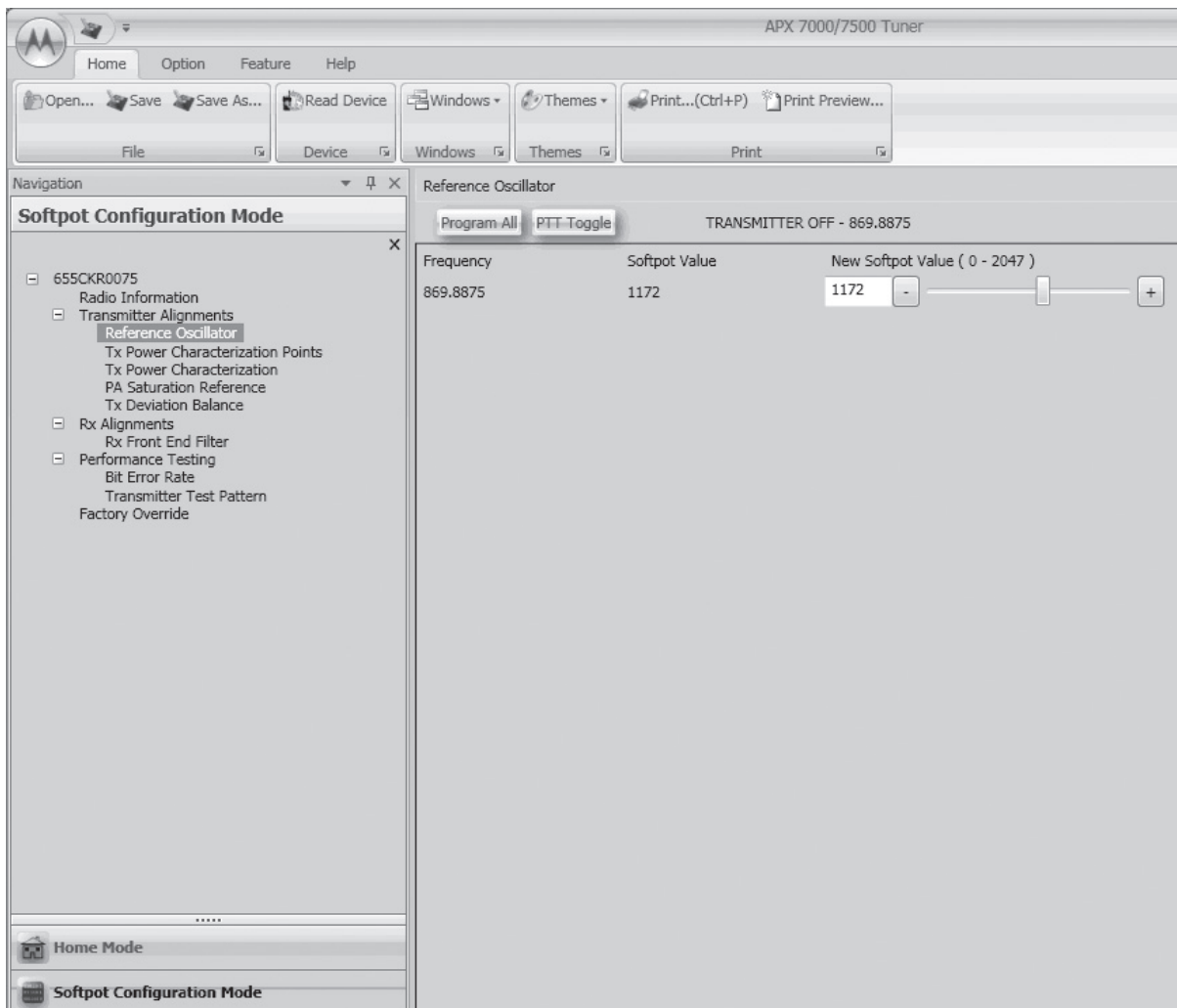

Figure 6-3. Typical Softpot Screen

Adjusting the softpot value sends information to the radio to increase (or decrease) the voltage in the corresponding circuit. For example, left-clicking the UP spin button in the New Softpot Value scroll box on the **Reference Oscillator** screen instructs the radio's microcomputer to increase the voltage across a varactor in the reference oscillator, which increases the frequency.

In ALL cases, the softpot value is just a relative number corresponding to a digital-to-analog (D/A) generated voltage in the radio.

Perform the following procedures in the sequence indicated.

**NOTE:** Some of the following screens may vary depending upon the radio under test and the version of tuner software you are using. Refer to the software's online help.



Caution

When keying the radio during a test, always transmit into a dummy load.

## 6.4 Radio Information

Figure 6-4 shows a typical Radio Information screen. This screen is informational only and cannot be directly changed.

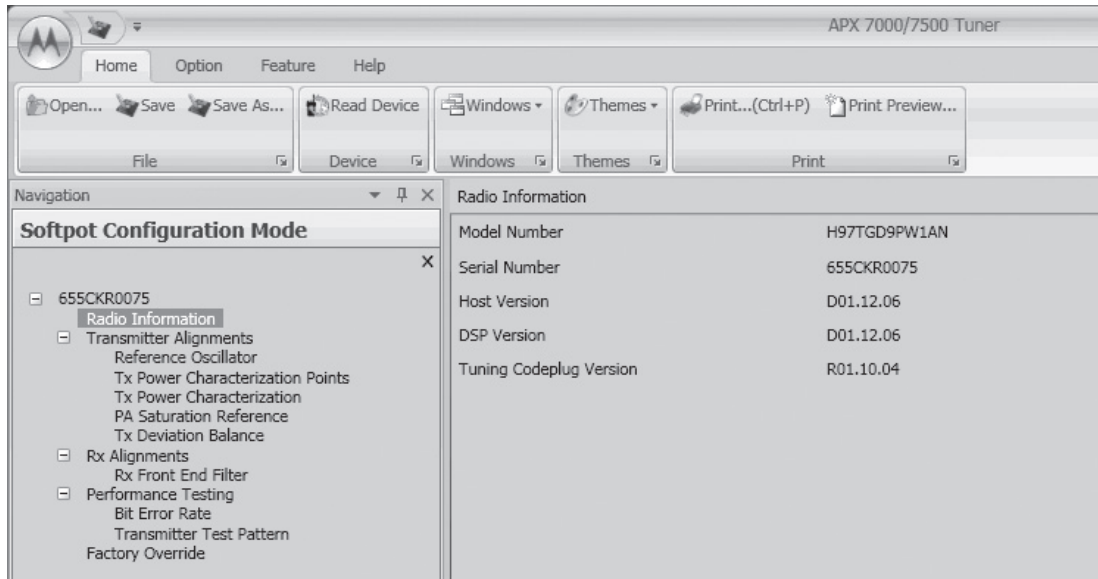

Figure 6-4. Radio Information Screen

## 6.5 Transmitter Alignments

### 6.5.1 Reference Oscillator Alignment

Adjustment of the reference oscillator is critical for proper radio operation. Improper adjustment will result not only in poor operation, but also in a misaligned radio that will interfere with other users operating on adjacent channels. For this reason, the reference oscillator should be checked every time the radio is serviced, or once a year, whichever comes first. The frequency counter used for this procedure must have a stability of 0.1 ppm (or better).

**NOTE:** Reference oscillator alignment is required after replacing (or servicing) the transceiver board.

This test can be done with either the R-2670 Communication Analyzer or the 8901\_ Modulation Analyzer.

- Initial setup using the R-2670 Communication Analyzer:
  - RF Control: MONITOR
  - B/W: WB
  - Freq: CPS frequency under test
  - Attenuation: 20dB
  - Mon RF in: RF I/O
  - Meter: RF Display
  - Mode: STD
  - Input Level: uV or W
  - Display: Bar Graphs
  - Squelch: Mid-range or adjust as necessary



- Initial setup using the 8901\_ Series Modulation Analyzer:
  - Press the green **Automatic Operation** button on the analyzer.
  - Press the **FREQ** key.
  - Type **7.1** followed by **SPCL** button to set the 8901B\_ modulation analyzer for maximum accuracy.

To align the reference oscillator:

1. Select the **Reference Oscillator** alignment screen. See [Figure 6-5](#), [Figure 6-6](#) and [Figure 6-7](#).

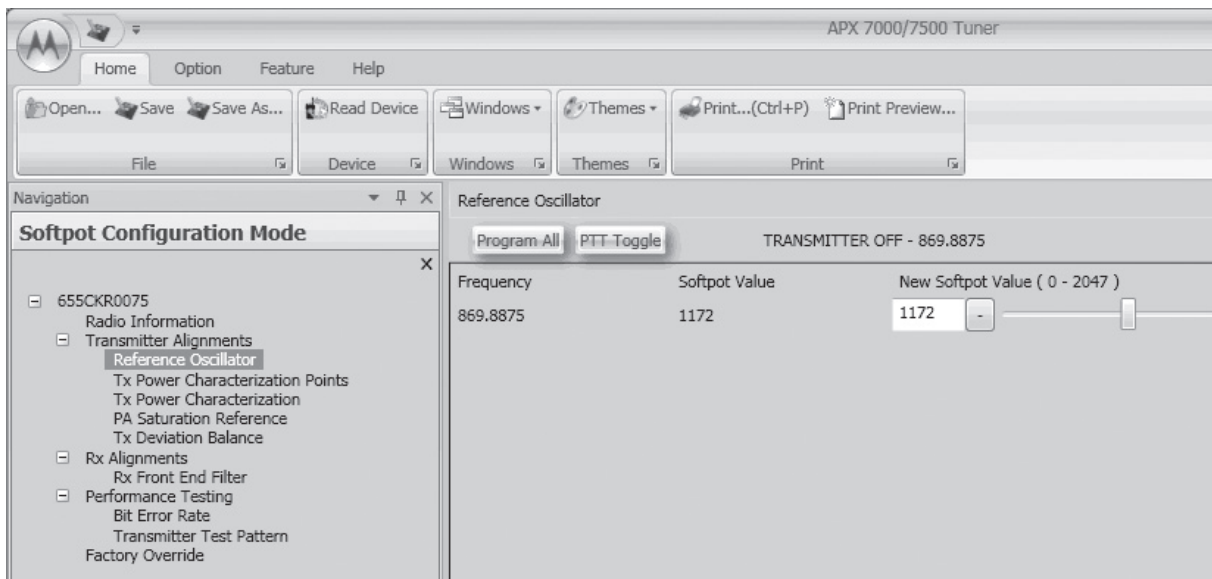

Figure 6-5. Reference Oscillator Alignment Screen (VHF and 700–800 MHz, UHF1 and 700–800 MHz, and UHF2 and 700–800 MHz)

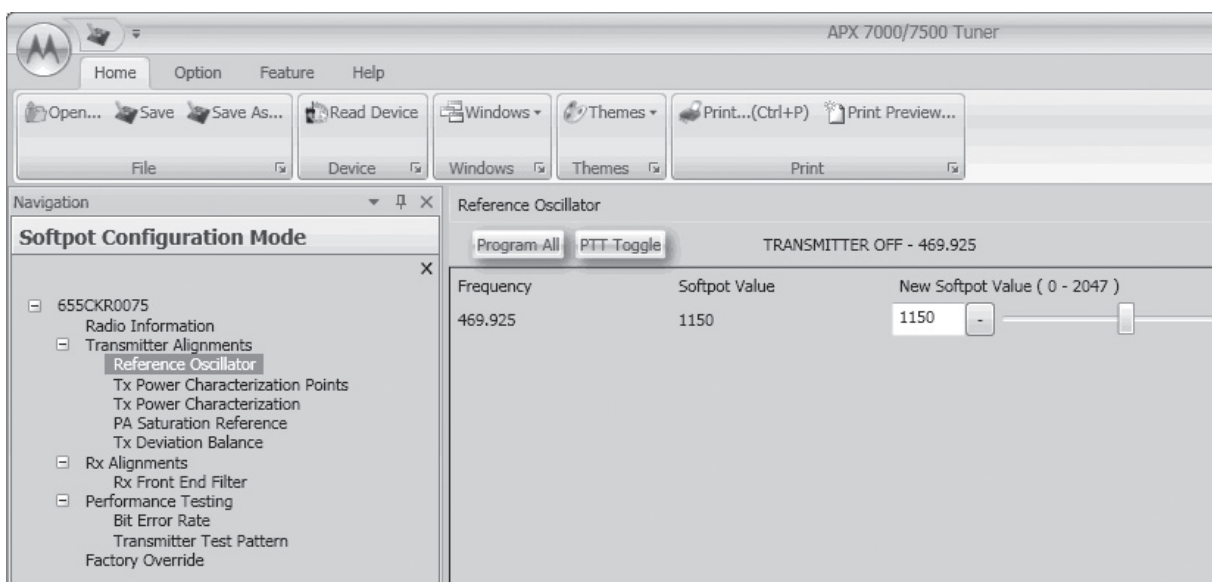

Figure 6-6. Reference Oscillator Alignment Screen (UHF1 and VHF, and UHF1 and UHF2)

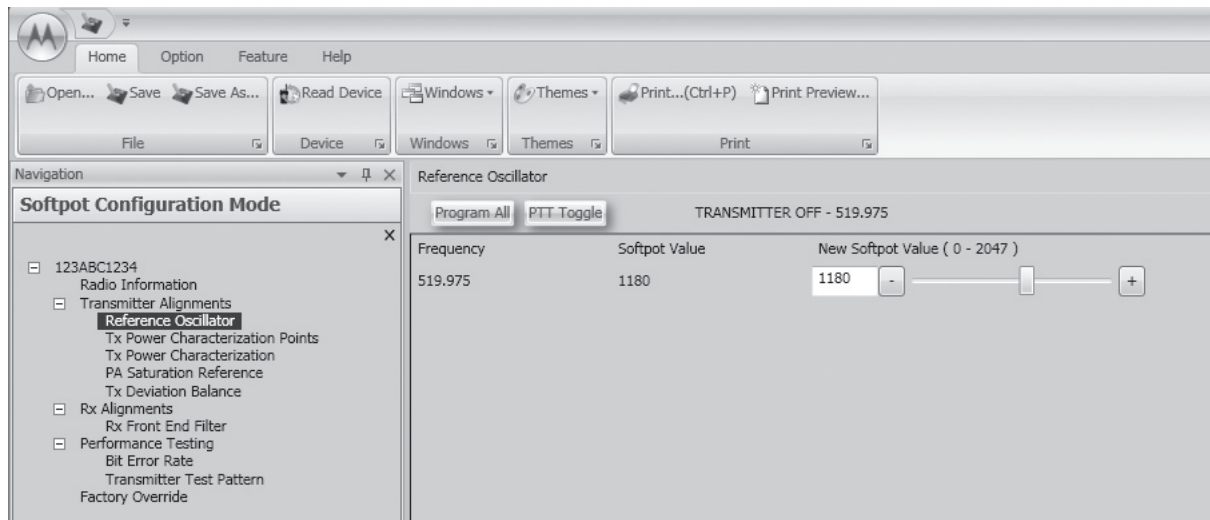

Figure 6-7. Reference Oscillator Alignment Screen (UHF2 and VHF)

2. Make sure the Communication Analyzer is in **Manual** mode.
  - VHF and 700–800 MHz, UHF1 and 700–800 MHz ,and, UHF2 and 700–800 MHz
    - Set the base frequency to 869.8875 MHz
  - UHF1 and VHF
    - Set the base frequency to 469.925 MHz
  - UHF1 and UHF2
    - Set the base frequency to 469.925 MHz
  - UHF2 and VHF
    - Set the base frequency to 519.975 MHz
3. Adjust the reference oscillator’s softpot value with the slider until the measured value is as close as possible to the frequency shown on the screen. See [Table 6-1](#).
 

**NOTE:** Increases the slider decreases the frequency and vice versa.

Table 6-1. Reference Oscillator Alignment

Band	Target
VHF	±50 Hz
700 MHz/800 MHz	±50 Hz
UHF1	±50 Hz
UHF2	±50 Hz

4. Left-click the **Program All** button on the screen to dekey the radio and save the tuned values.
5. Left-click the **Close** button on the screen to return to the **Transmitter Alignments** menu.

## 6.5.2 Power Characterization Points

Tuning of the radio is done through **Power Characterization Points** tuning screen.

1. Select the **TX Power Characterization Points** alignment screen.  
See [Figure 6-8](#) to [Figure 6-13](#).
2. Set power supply voltage and current limit.
3. Adjust softpot value by manipulating the slider bar, incrementing the "New Softpot Value" text box, or directly entering the desired value into the "New Softpot Value" text box until the rated power is indicated on the service monitor. For rated power refer to the help text in the Tuner.
4. Repeat the steps 2 and 3 for all frequencies.
5. Left-click the **Program All** button on the screen to dekey the radio and save the tuned values.

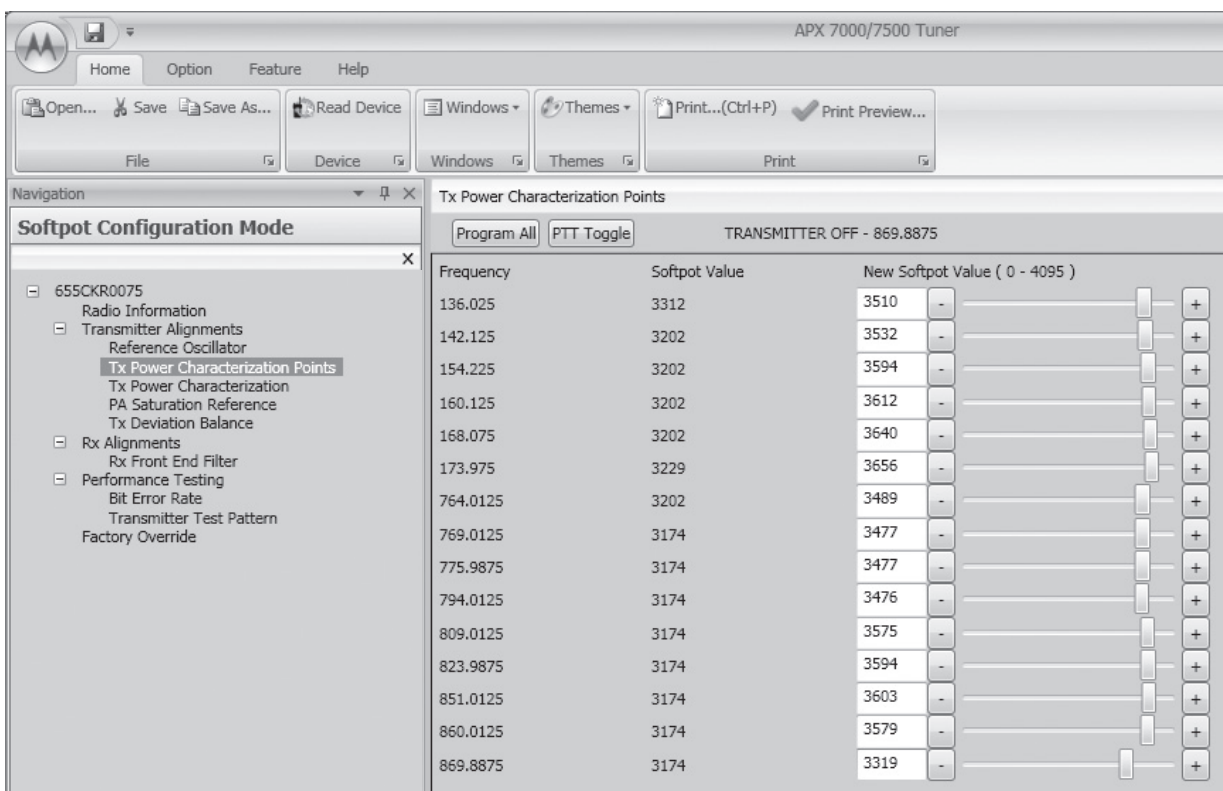

Figure 6-8. Transmit Power Characterization Points Alignment Screen (VHF and 700–800 MHz)

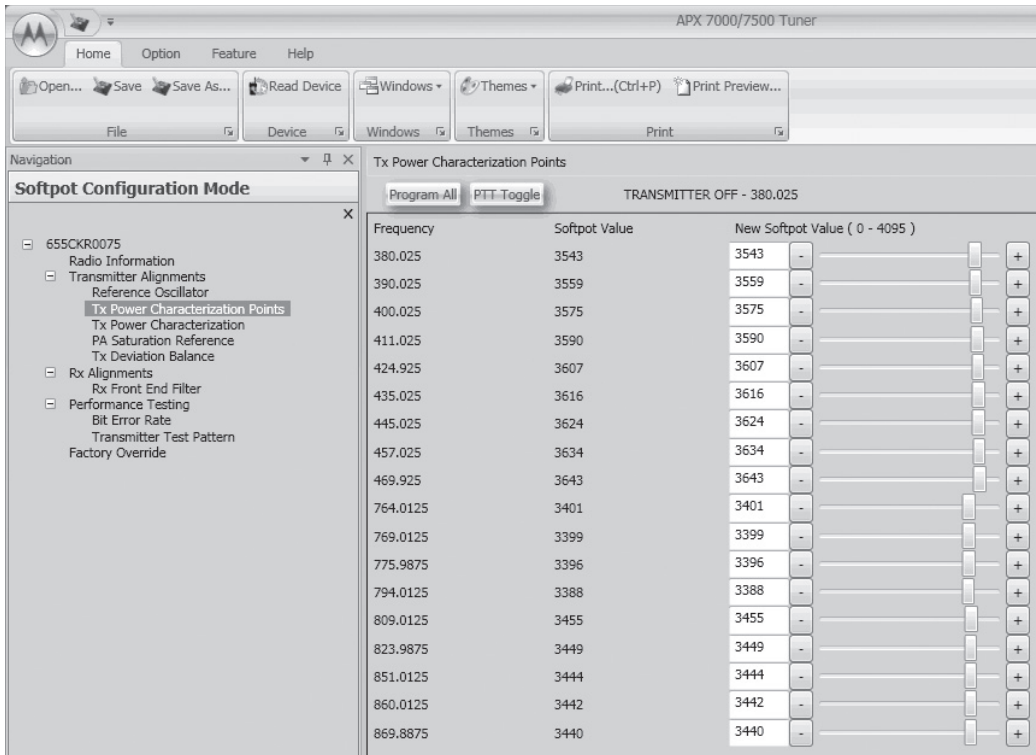

Figure 6-9. Transmit Power Characterization Points Alignment Screen (UHF1 and 700–800 MHz)

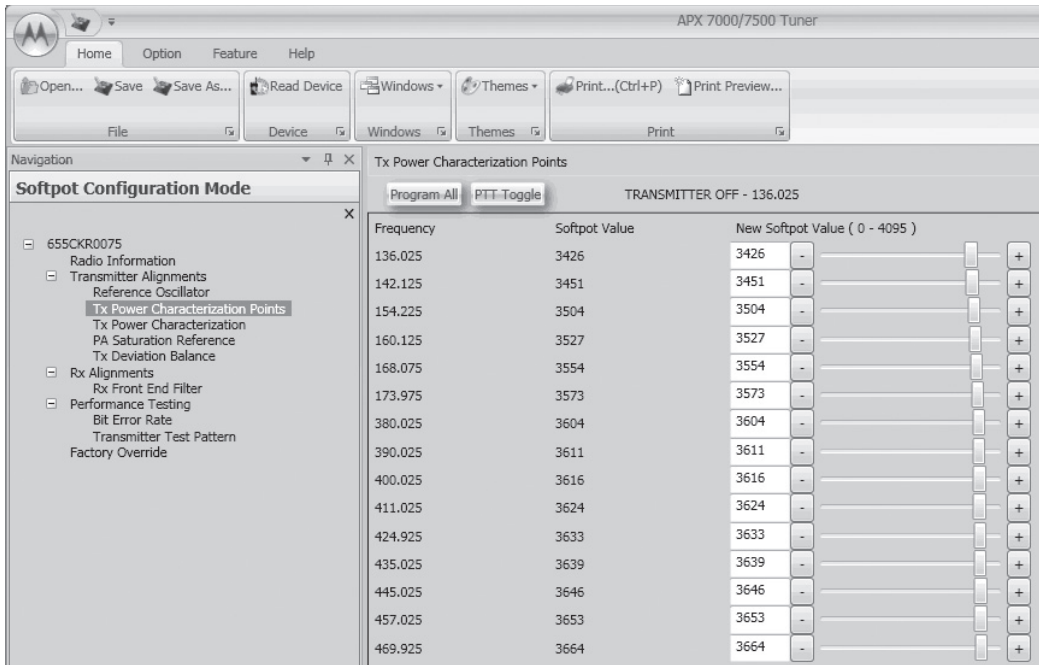

Figure 6-10. Transmit Power Characterization Points Alignment Screen (UHF1 and VHF)

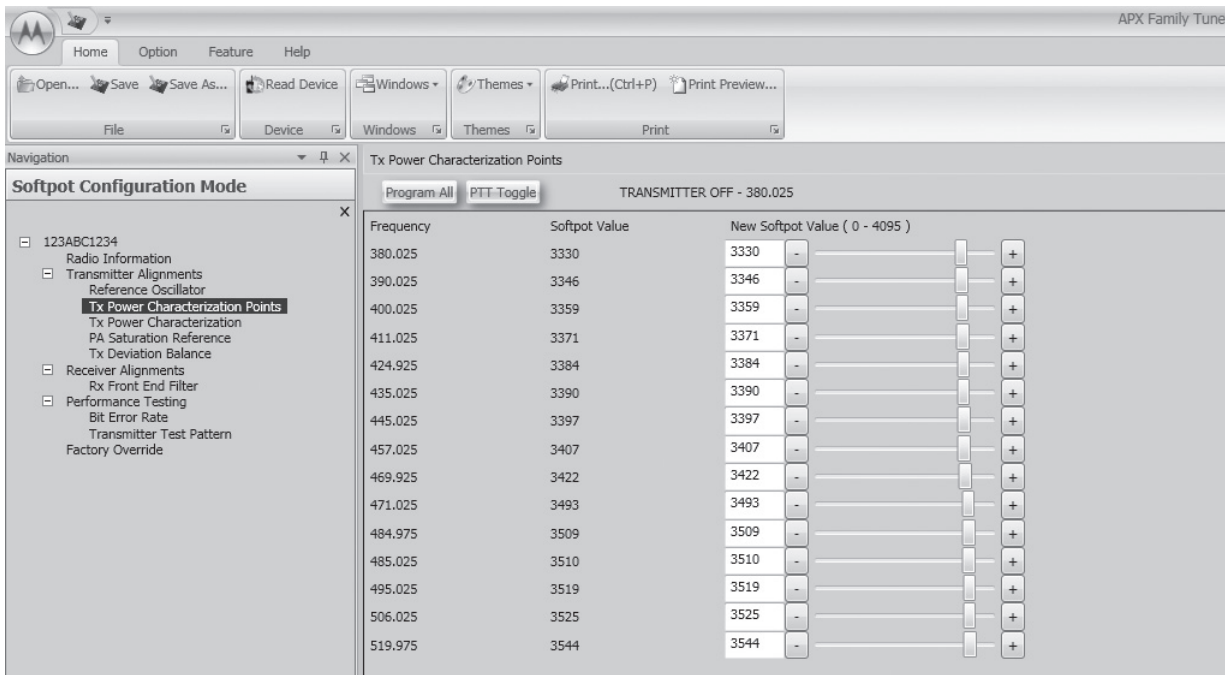

Figure 6-11. Transmit Power Characterization Points Alignment Screen (UHF1 and UHF2)

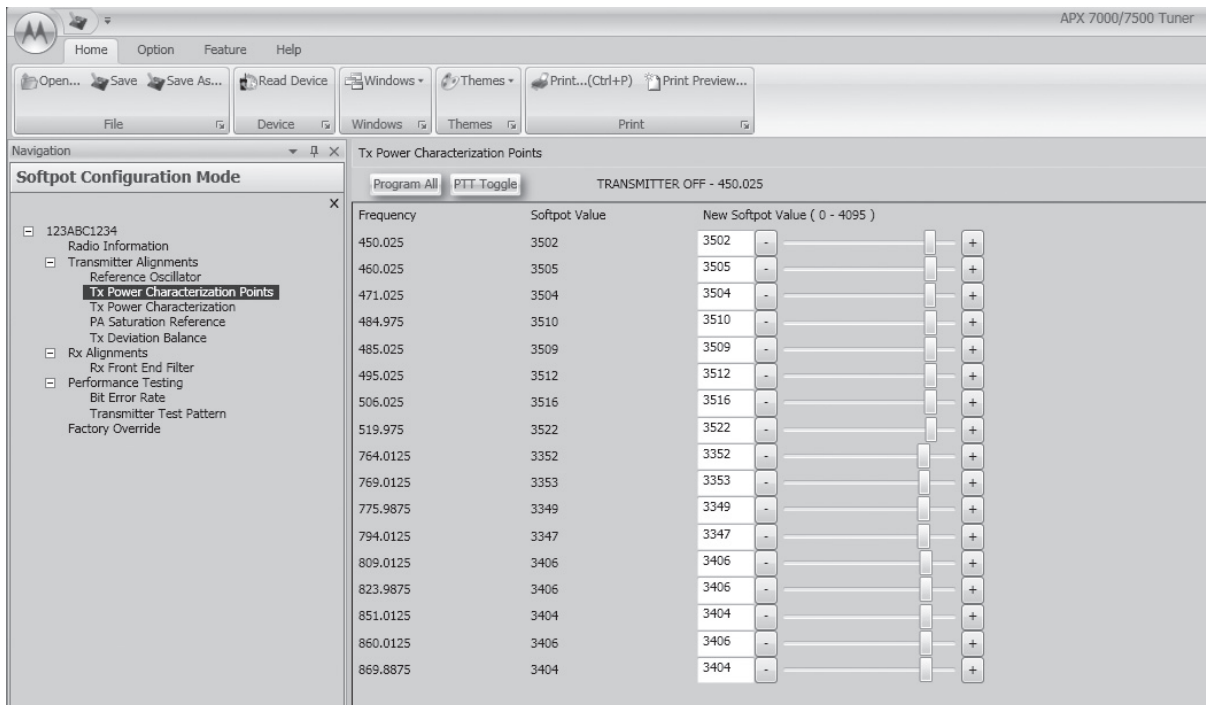

Figure 6-12. Transmit Power Characterization Points Alignment Screen (UHF2 and 700–800 MHz)

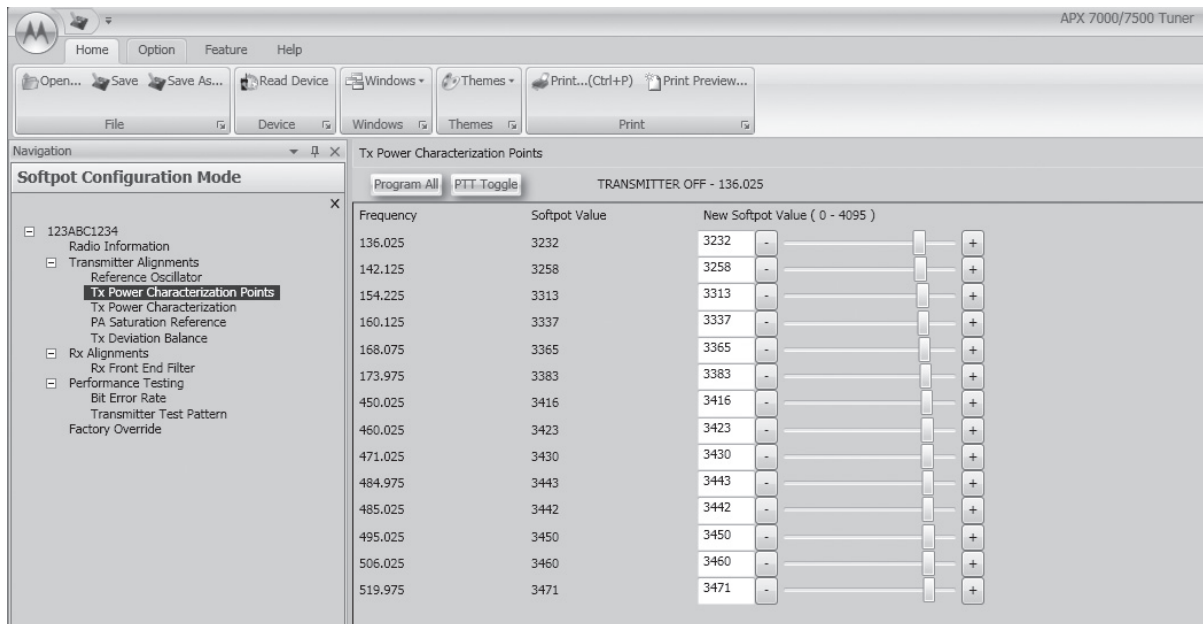

Figure 6-13. Transmit Power Characterization Points Alignment Screen (UHF2 and VHF)

### 6.5.3 Power Characterization Tuning

Tuning of the radio is done through **Power Characterization** tuning screen.

**IMPORTANT:** Power Characterization Tuning Points must be tuned before tuning Power Characterization Tuning.

**NOTE:** a. The longer the RF cable, the more the attenuation of the power reading.

b. Use a standard 50 ohm cable

c. Remember to set the Communication Analyzer to baseband power.

1. Select the **TX Power Characterization** alignment screen. The screen indicates the transmit power to be used. See [Figure 6-14](#) to [Figure 6-19](#).
2. Left-click the box under “Measure Power 1” for the desired frequency field. (The selected box is highlighted).
3. Click the **PTT Toggle** button on the screen to make the radio transmit. The screen indicates whether the radio is transmitting.
4. Measure the transmit power of the radio with a service monitor.
5. Input the transmit power in watts using two decimal places into the highlighted “Measure Power 1” box.
6. Left-click the box under “Measure Power 2” box for the same frequency field. (The selected box is highlighted).
7. Measure the transmit power of the radio with a service monitor.
8. Input the transmit power in watts using two decimal places into the highlighted “Measure Power 2” box.
9. Repeat steps 2 to 8 for all frequencies.
10. Left-click the **Program All** button on the screen to dekey the radio and save the tuned values.

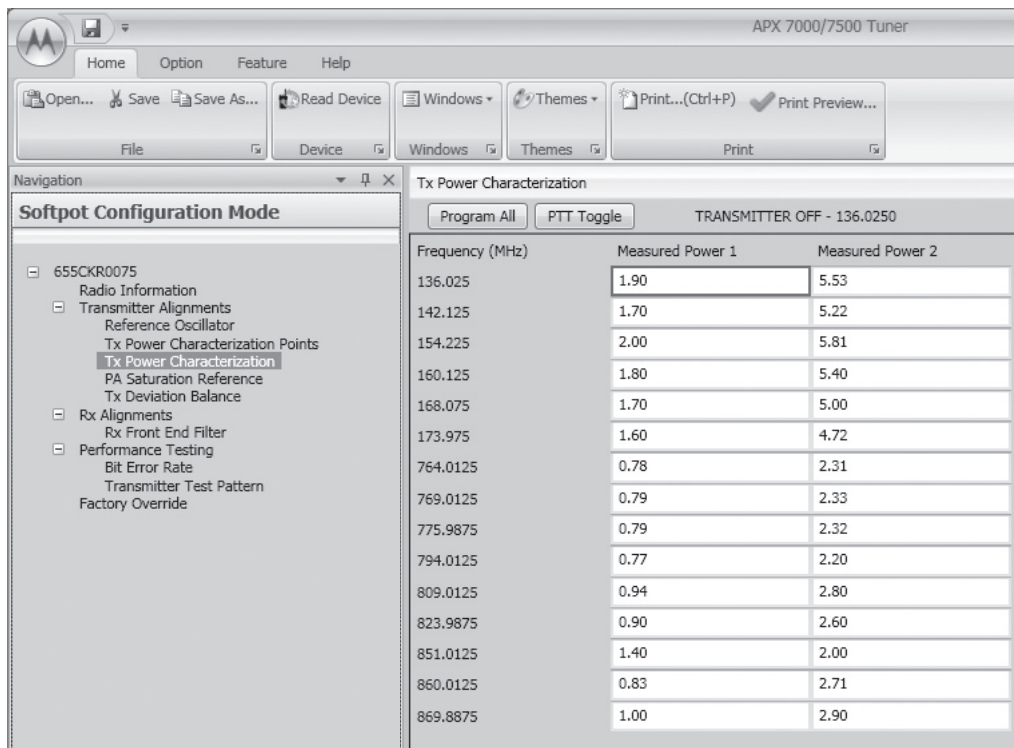

Figure 6-14. Transmit Power Characterization Alignment Screen (VHF and 700–800 MHz)

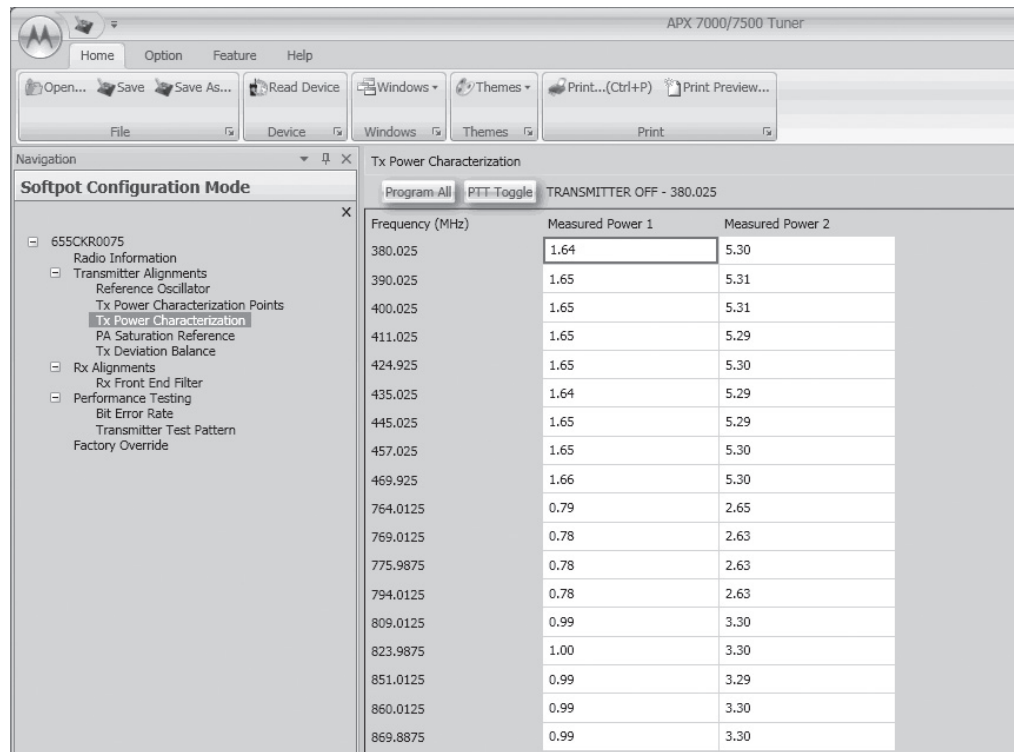

Figure 6-15. Transmit Power Characterization Alignment Screen (UHF1 and 700–800 MHz)



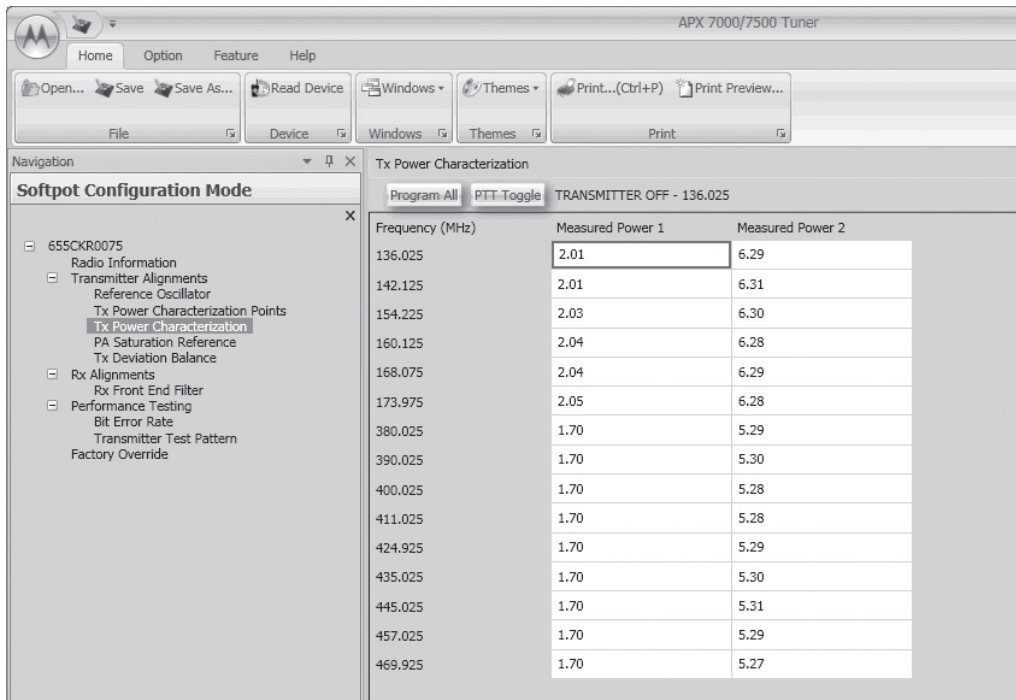

Figure 6-16. Transmit Power Characterization Alignment Screen (UHF1 and VHF)

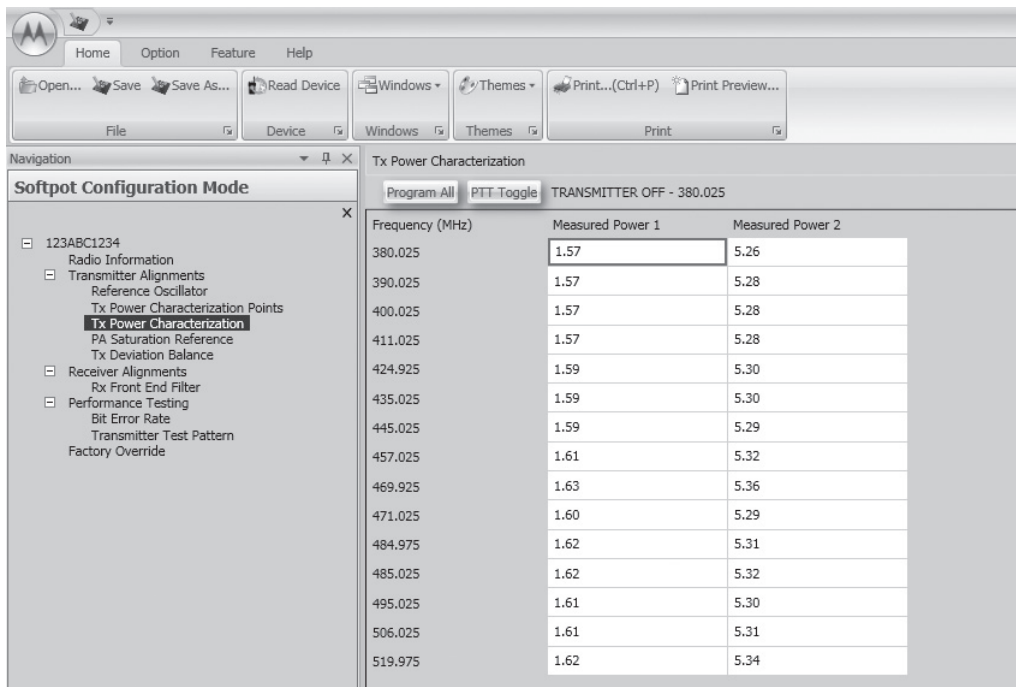

Figure 6-17. Transmit Power Characterization Alignment Screen (UHF1 and UHF2)



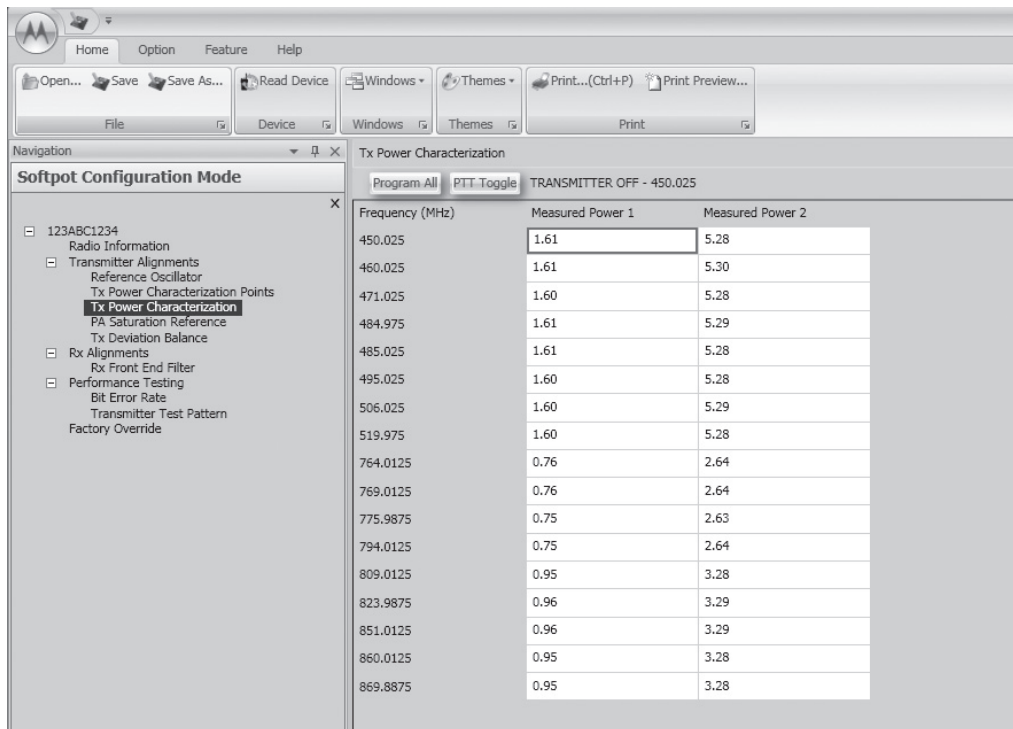

Figure 6-18. Transmit Power Characterization Alignment Screen (UHF2 and 700–800 MHz)

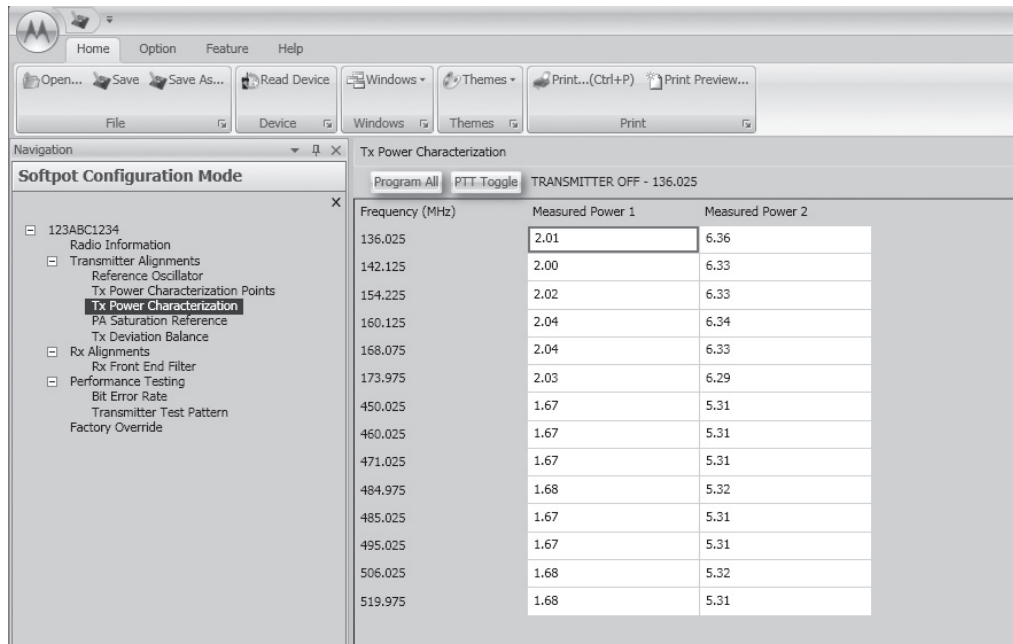

Figure 6-19. Transmit Power Characterization Alignment Screen (UHF2 and VHF)

### 6.5.4 PA Saturation Reference Tuning

Tuning is done through **PA Saturation Referencing** screen.

1. Select the **PA Saturation Reference** alignment screen. The screen indicates the transmit frequencies to be used. See [Figure 6-20](#) to [Figure 6-25](#).
2. In Manual Mode, set the service monitor to the desired frequency (as shown in the frequency list in the PA Saturation Reference alignment screen).
3. Adjust the PA Saturation Reference softpot value with the slider until the radio transmits as close as possible to the rated power. For rated power refer to the help text in the Tuner.
4. Left-click the slider of the frequency selected (should be the same frequency as step 2).
5. Left-click the **PTT Toggle** button on the screen to make the radio transmit. The screen indicates whether the radio is transmitting.
6. Repeat the steps 2 to 5 for all frequencies.
7. Left-click the **Program All** button on the screen to dekey the radio and save the tuned values.

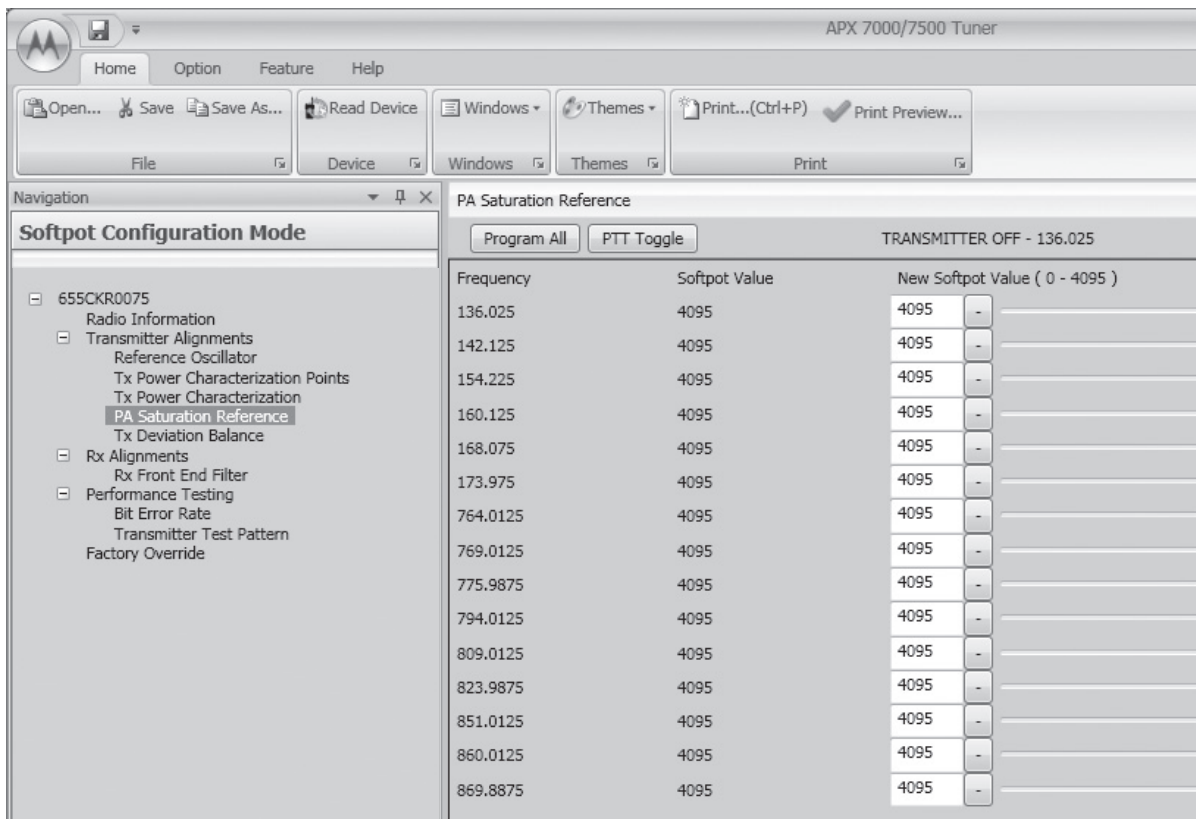

Figure 6-20. PA Saturation Referencing Alignment Screen (VHF and 700–800 MHz)

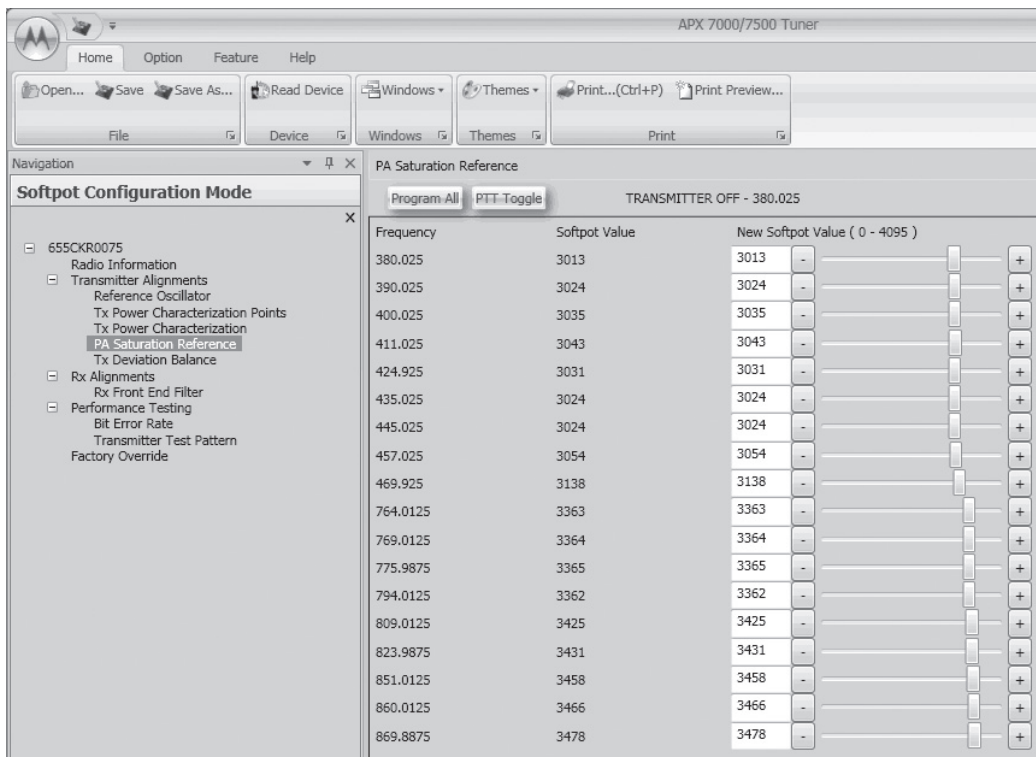

Figure 6-21. PA Saturation Referencing Alignment Screen (UHF1 and 700–800 MHz)

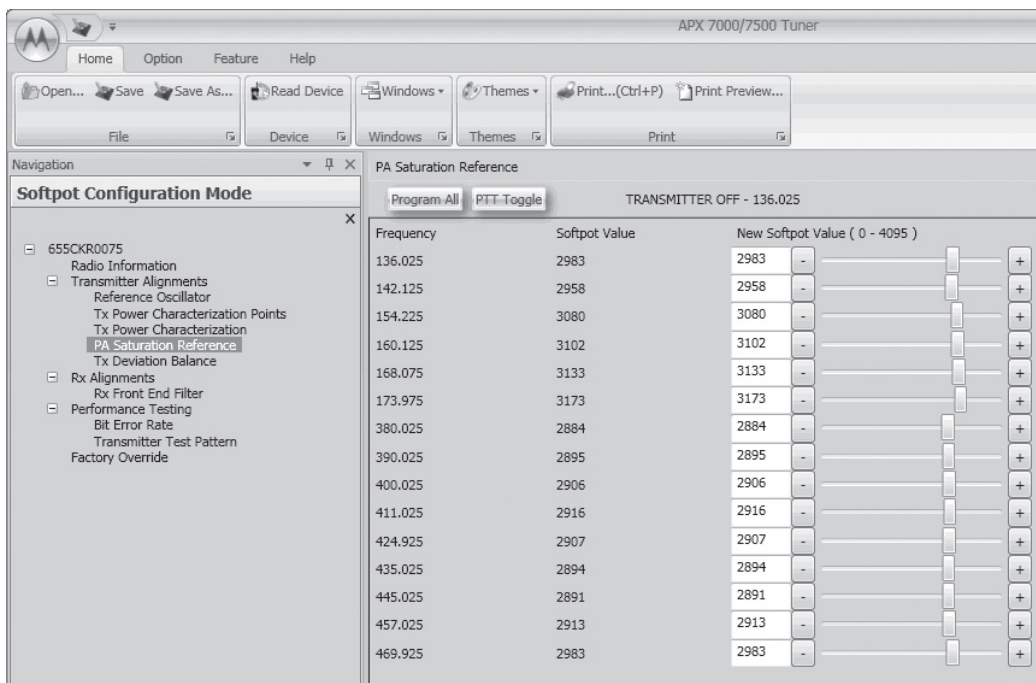

Figure 6-22. PA Saturation Referencing Alignment Screen (UHF1 and VHF)

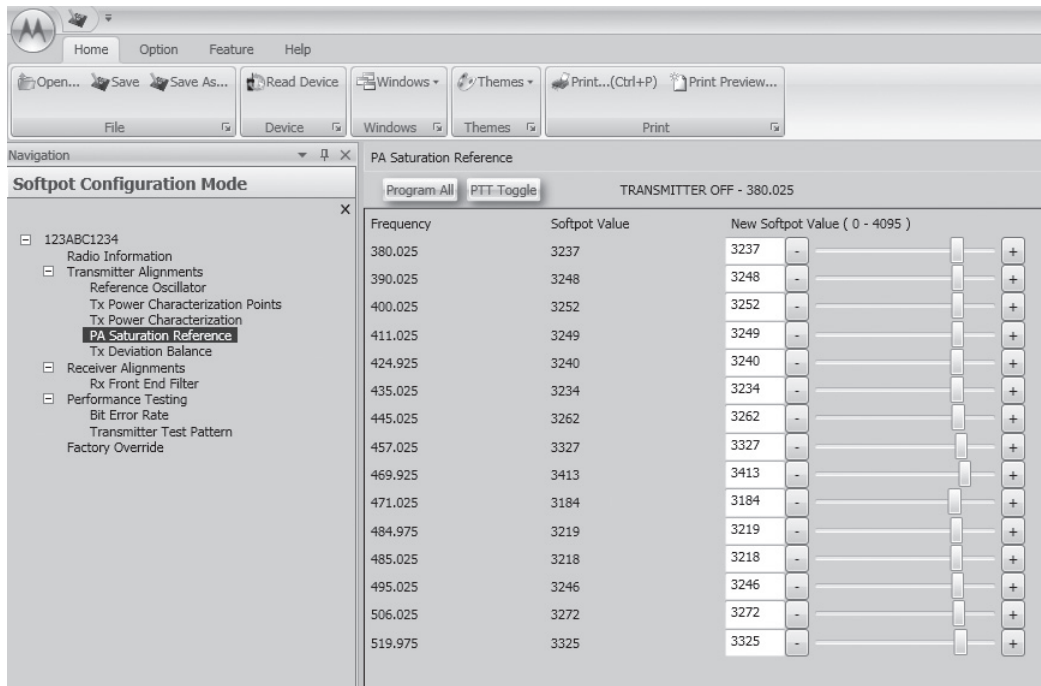

Figure 6-23. PA Saturation Referencing Alignment Screen (UHF1 and UHF2)

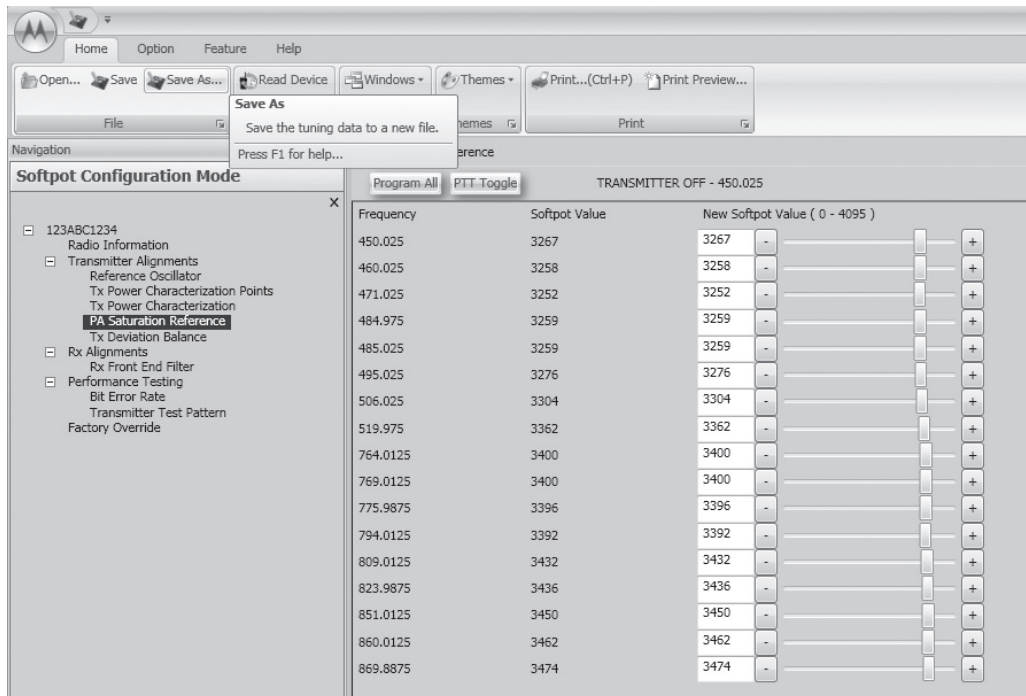

Figure 6-24. PA Saturation Referencing Alignment Screen (UHF2 and 700–800 MHz)

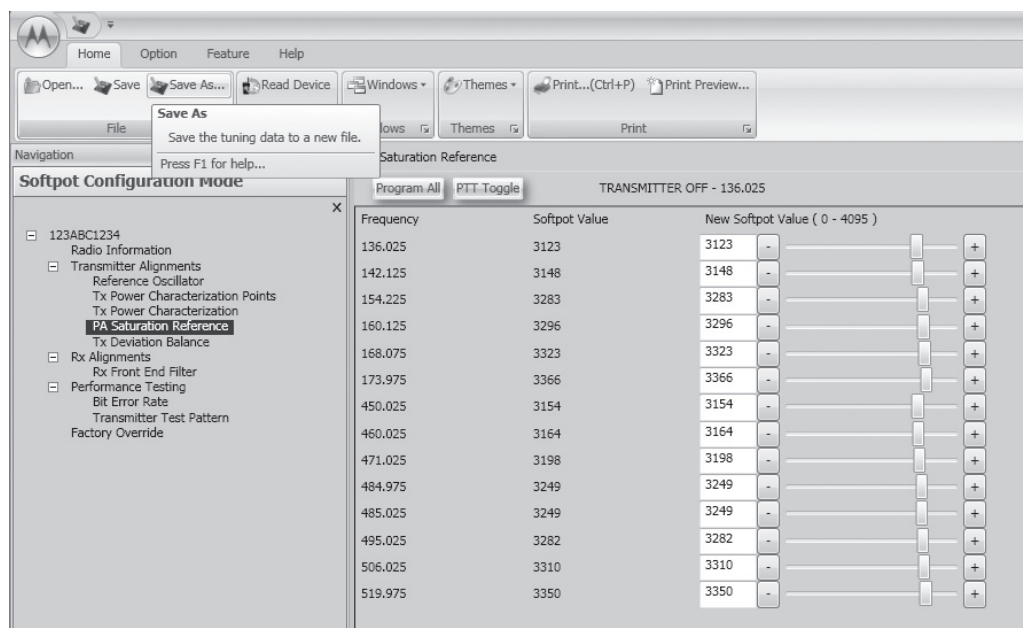

Figure 6-25. PA Saturation Referencing Alignment Screen (UHF2 and VHF)

### 6.5.5 Transmit Deviation Balance Alignment

This alignment procedure balances the modulation contributions of the low- and high-frequency portions of a baseband signal. Proper alignment is critical to the operation of signalling schemes that have very low frequency components (for example, DPL) and could result in distorted waveforms if improperly adjusted.

This procedure needs to be performed at multiple frequencies to allow for proper alignment across the entire RF band. The RF band is divided into frequency zones with a calibration point (value) in each zone.

**NOTE:** This alignment is required after replacing (or servicing) the VOCON board or the transceiver board.

Proper alignment requires a modulation analyzer or meter with a frequency response to less than 10 Hz modulating frequency. The modulation analyzer settings during this test should be set for average deviation, a 15 kHz low-pass filter, no de-emphasis, and no high-pass filter, if these settings are supported.

This alignment can be done with either the R-2670 Communication Analyzer or the 8901\_ Series Modulation Analyzer. The method of choice is the R-2670 analyzer.

1. Initial setup using the R-2670 Communication Analyzer:
  - Connect a BNC cable between the “DEMOD OUT” port and the “VERT/SINAD DIST/DMM COUNTER IN” port on the R-2670.
  - Press the **SPF** key on the R-2670 to display the “SPECIAL FUNCTIONS MENU.” Move the cursor to “High Pass,” and select 5 Hz on the soft key menu. Select 20 kHz for the “Low Pass” setting.
  - In the “RF Control” section of the R-2670, move the cursor to the “B/W” setting and select “WIDE +/- 100 kHz” on the soft key menu.
  - Place the R-2670 cursor in the “Display” zone. Select “AC VOLTS” on the soft key menu. Move the cursor to the “Range” setting and select “AUTO.”

2. Initial setup using the 8901\_ Series Modulation Analyzer:
  - Press the **FM MEASUREMENT** button. (The “Error 03-input level too low” indication is normal until an input signal is applied.)
  - Simultaneously press the **Peak –** and **Peak +** buttons. Both LEDs on the buttons should light.
  - Press the 15 kHz LP filter key.
3. Select the **TX Deviation Balance** alignment screen. The screen indicates the transmit frequencies to be used. See [Figure 6-26](#) to [Figure 6-31](#).
4. In the "RF Control" section of the R2670, set the service monitor to the desired frequency (as shown in the frequency list in the TX Deviation Balance alignment screen).
5. Left-click the **PTT Tone: Low** button.
6. Left-click the slider of the frequency selected (should be the same frequency as step 4).
7. Left-click the **PTT Toggle** button on the screen to make the radio transmit. The screen indicates whether the radio is transmitting.
8. Measure and Record the Low Tone Tx Deviation value from the 8901\_ Series Analyzer or the AC voltage value from the R2670.

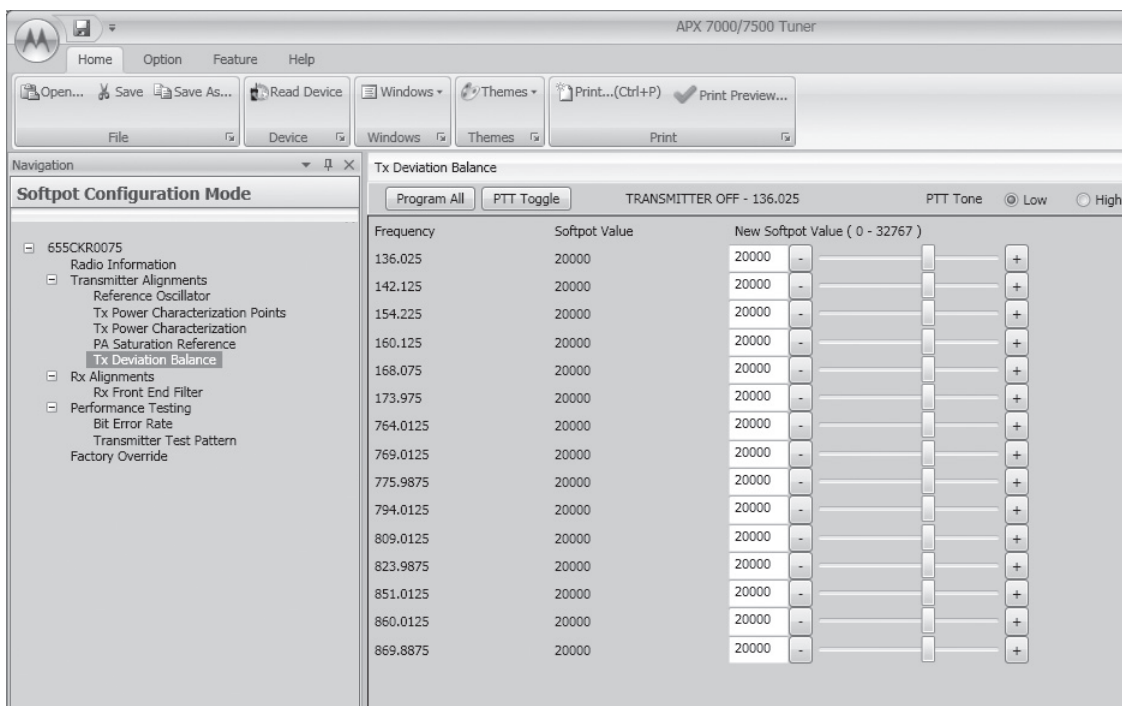

Figure 6-26. Transmit Deviation Balance Alignment Screen (VHF and 700–800 MHz)



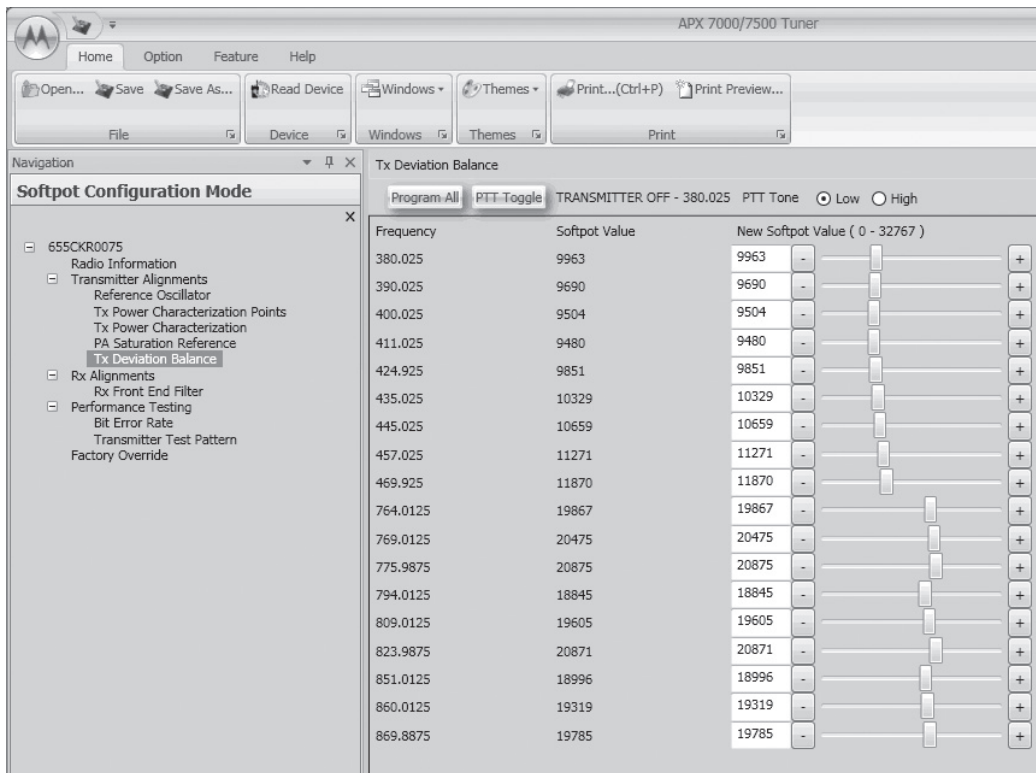

Figure 6-27. Transmit Deviation Balance Alignment Screen (UHF1 and 700–800 MHz)

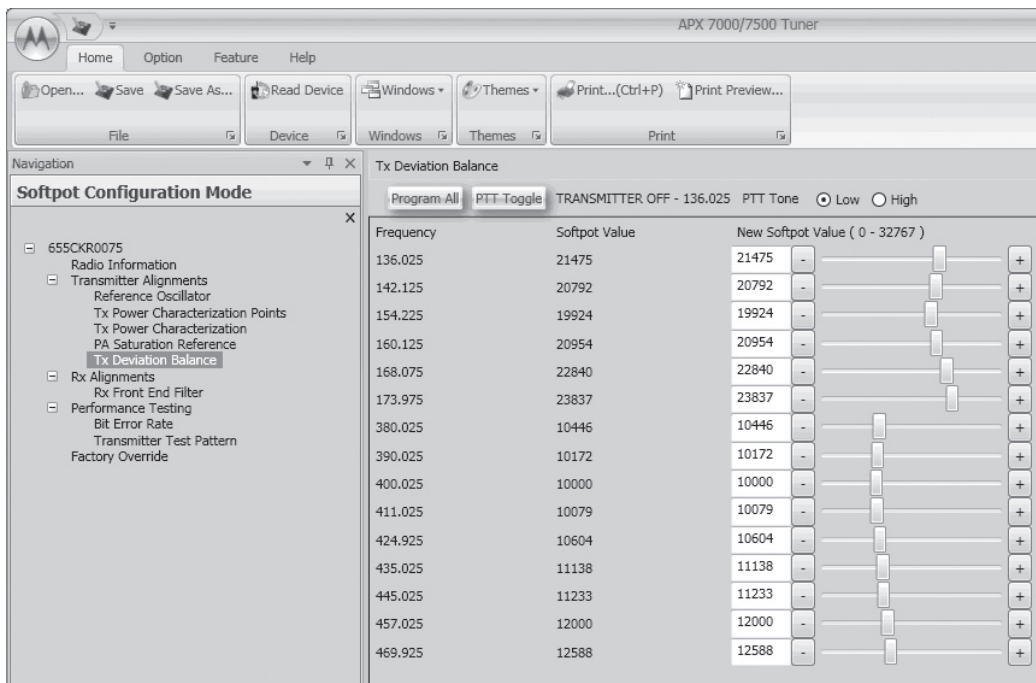

Figure 6-28. Transmit Deviation Balance Alignment Screen (UHF1 and VHF)

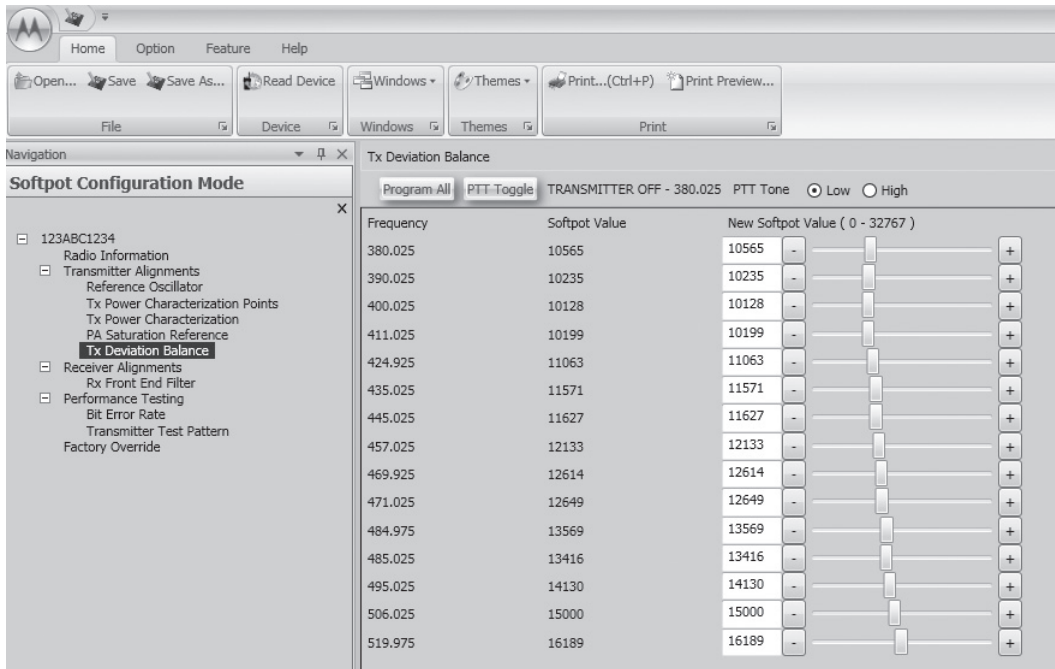

Figure 6-29. Transmit Deviation Balance Alignment Screen (UHF1 and UHF2)

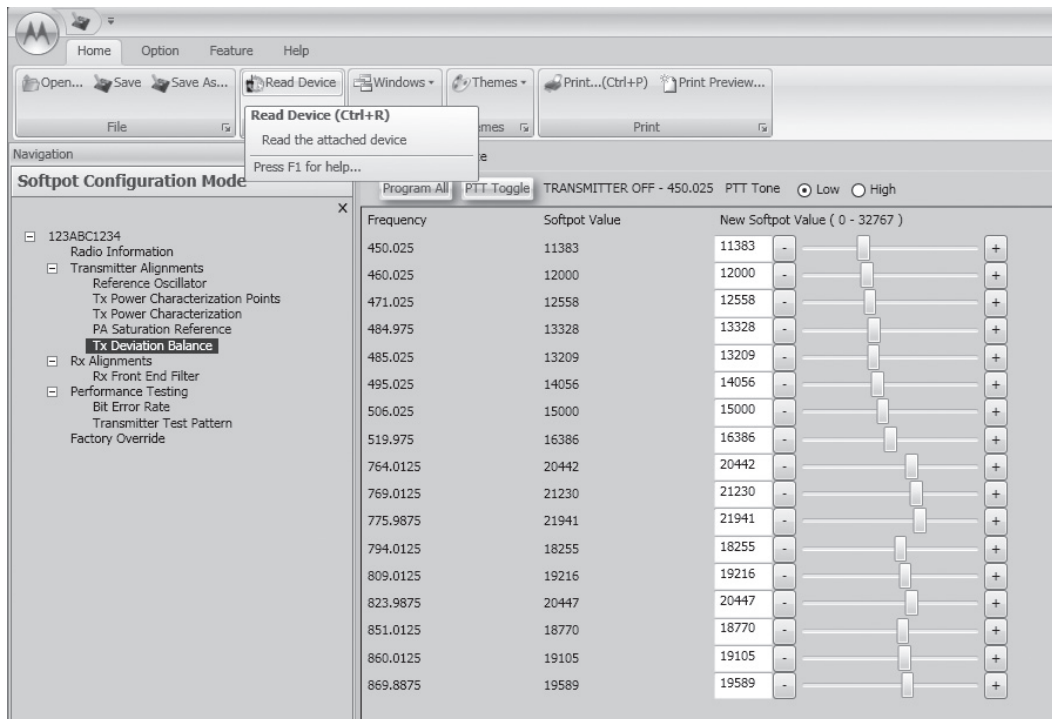

Figure 6-30. Transmit Deviation Balance Alignment Screen (UHF2 and 700–800 MHz)



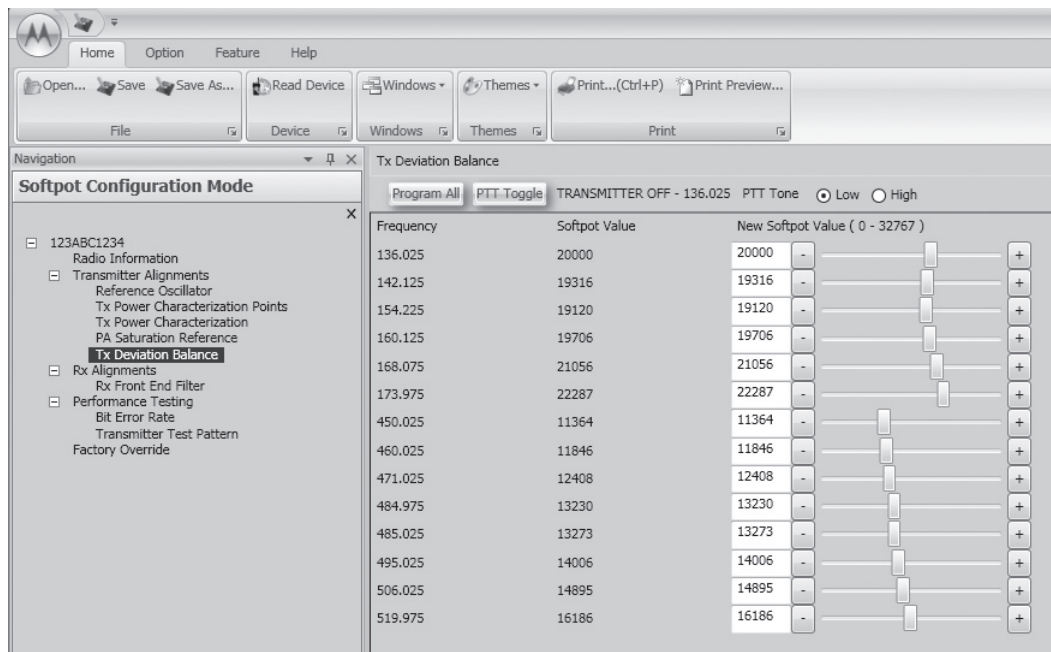



Figure 6-31. Transmit Deviation Balance Alignment Screen (UHF2 and VHF)

9. Left-click the **PTT Tone: High** button.
10. Adjust the softpot value until the measured deviation/voltage, when using the high tone, is within +/- 1.5% of the value observed when using the Low Tone.
11. Left-click the **PTT Toggle** to de-key the radio.
12. Repeat the steps 4 to 10 for all frequencies.
13. Left-click the **Program All** button on the screen to dekey the radio and save the tuned values.

## 6.6 Front End Filter Alignment



This procedure should only be attempted by qualified service technicians.

Caution

The alignment procedure adjusts the front end receiver bandpass filters for the best receiver sensitivity and selectivity. This procedure should be performed for all test frequencies to allow for proper software interpolation of frequencies between the test frequencies in the band (see [Figure 6-32](#) and [Figure 6-33](#)).

**NOTE:** Rx Front End Filter Alignment is required after replacing (or servicing) the transceiver board.

### 6.6.1 Procedure for UHF Range 1 (Auto Tune)

Tuning of the radio is done through **Rx Front End Filter** tuning screen

1. Select the **Rx Front End Filter** alignment screen. See [Figure 6-32](#).
2. Click on the slider or the "New Softpot Value" text box to select which frequency to tune.
3. Apply RF test signal input with no modulation at -14 dBm on the Test Signal Frequency displayed at the top of the screen.
4. Left-click the **Autotune** button.
5. Repeat the steps 2–4 for all frequencies.
6. Left-click the **Program All** button on the screen to save the tuned values in the radio.

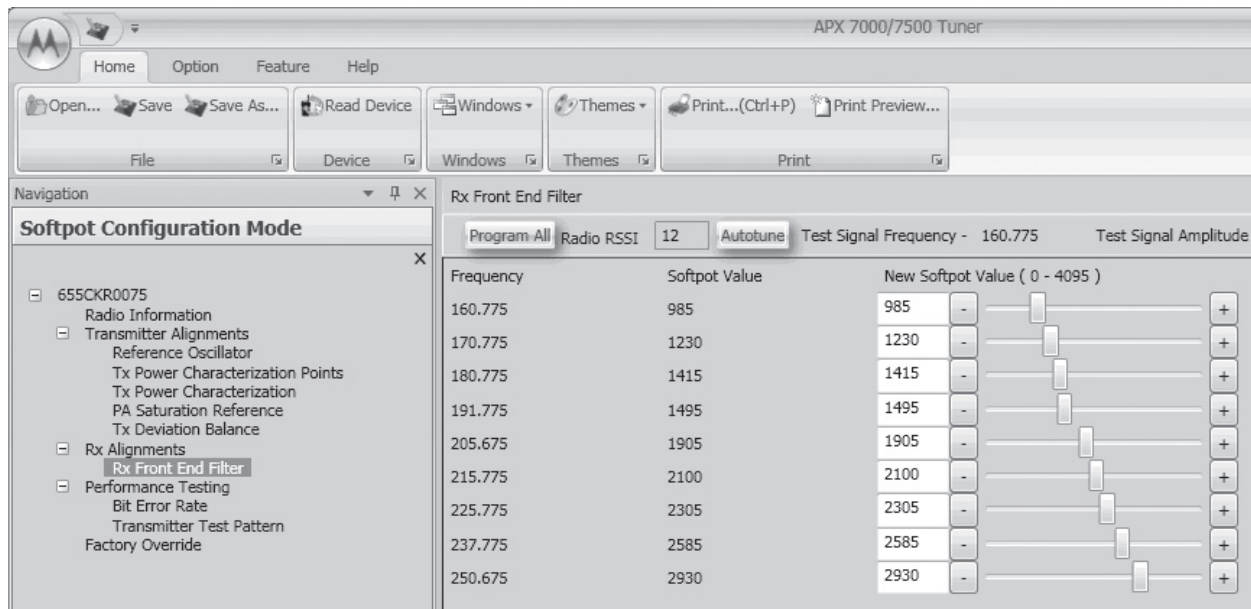

Figure 6-32. Front End Filter Alignment Screen (UHF1)

## 6.6.2 Procedure for UHF Range 2 (Auto Tune)

Tuning of the radio is done through **Rx Front End Filter** tuning screen

1. Select the **Rx Front End Filter** alignment screen. See [Figure 6-33](#).
2. Click on the slider or the "New Softpot Value" text box to select which frequency to tune.
3. Apply RF test signal input with no modulation at -14 dBm on the Test Signal Frequency displayed at the top of the screen.
4. Left-click the **Autotune** button.
5. Repeat the steps 2–4 for all frequencies.
6. Left-click the **Program All** button on the screen to save the tuned values in the radio.

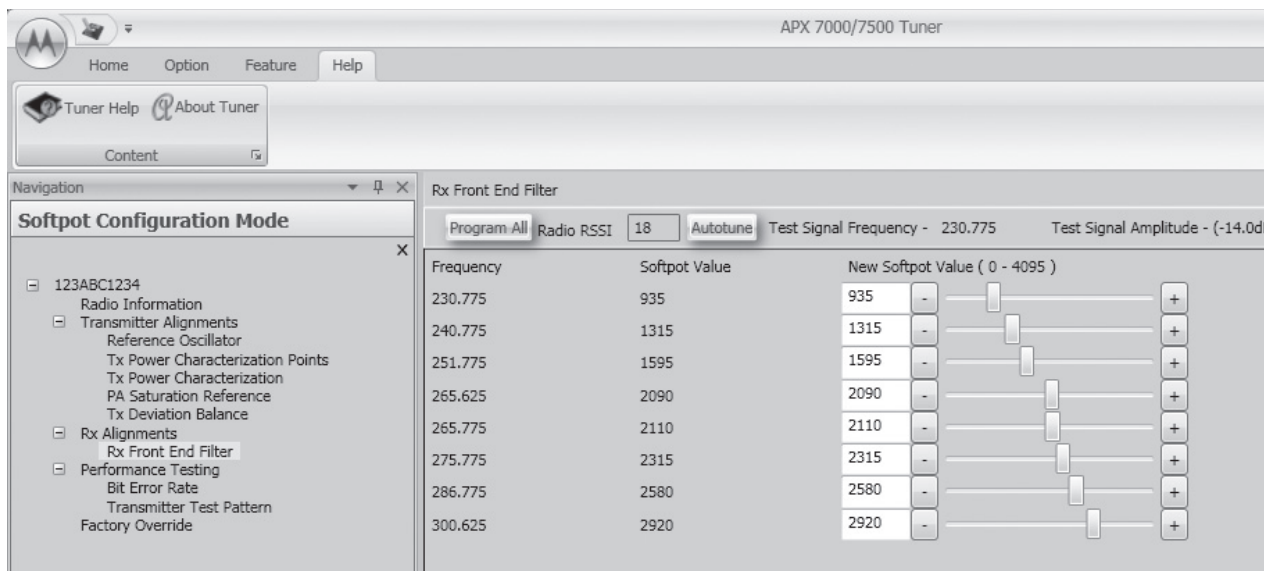

Figure 6-33. Front End Filter Alignment Screen (UHF2)

## 6.7 Performance Testing

### 6.7.1 Bit Error Rate

This section describes the Bit Error Rate (BER) test of the radio's receiver at a desired frequency (see [Figure 6-34](#)).

#### 6.7.1.1 Bit Error Rate Fields

Set up the R2670 Communication Analyzer as follows:

1. Connect the RF Input port of the radio under test to the RF IN/OUT port of the R2670 Service Monitor.
2. Set up the R2670 Service Monitor:
  - In the Display Zone, select PROJ 25 STD mode and set the meter to RF DISPLAY.
  - In the RF Zone, configure the analyzer as follows:
 

RF Control:	Generate
Preset:	B/W: NB
Freq:	Test frequency (Ex: 851.0625 MHz)
Output Level:	-50.0 dBm
Gen RF Out:	RF I/O
  - In the Audio Zone, select the 1011 Hz PAT code and set the deviation to "PROJ25Dev: 2.83 kHz ~".

The bit error rate screen contains the following fields:

- **Rx Frequency:**  
This field selects the Receive Frequency directly in MHz.
  - **Test Pattern:**  
This field selects the Digital test pattern to be received by the radio. Choices are: Standard Tone Test Pattern (Framed 1011), F2 1031 and Standard Interface Test Pattern (CCITT V.52).
  - **Modulation Type:**  
This field represents the digital modulation type of the incoming signal on which BER is to be calculated.
  - **Continuous Operation:**  
This field allows the user the option to repeat the BER test indefinitely. A selection of Yes will cause the radio to calculate BER on a continuous basis and update the results on this screen after each integration time. A selection of No will cause the BER test to execute for only one sample of the integration time and then update the display.
  - **Audio:**  
This field allows the user to select the audio output during a test. Selecting Internal will cause the radio's built-in speaker to unmute to any signals at the desired frequency which are present during the test. Selecting External will route the same signal to the radio's accessory connector audio output. Selecting Mute will disable the audio output.
- NOTE:** There will be **no audio** option available for APX 7000XE when performing a Bit Error Rate Test.
- **BER Integration Time:**  
BER Integration Time carries with Test Pattern Type.
  - **Number of Frames**  
Number of Frames over which bit error result are accumulated to produce the result.

**NOTE:** When **Continuous Operation = Yes**, all fields will be grayed out while the test is in progress. They will be enabled when the STOP button is pressed.

When **Continuous Operation = No**, a wait cursor will be displayed while the test is in progress and return to normal when the test is done.

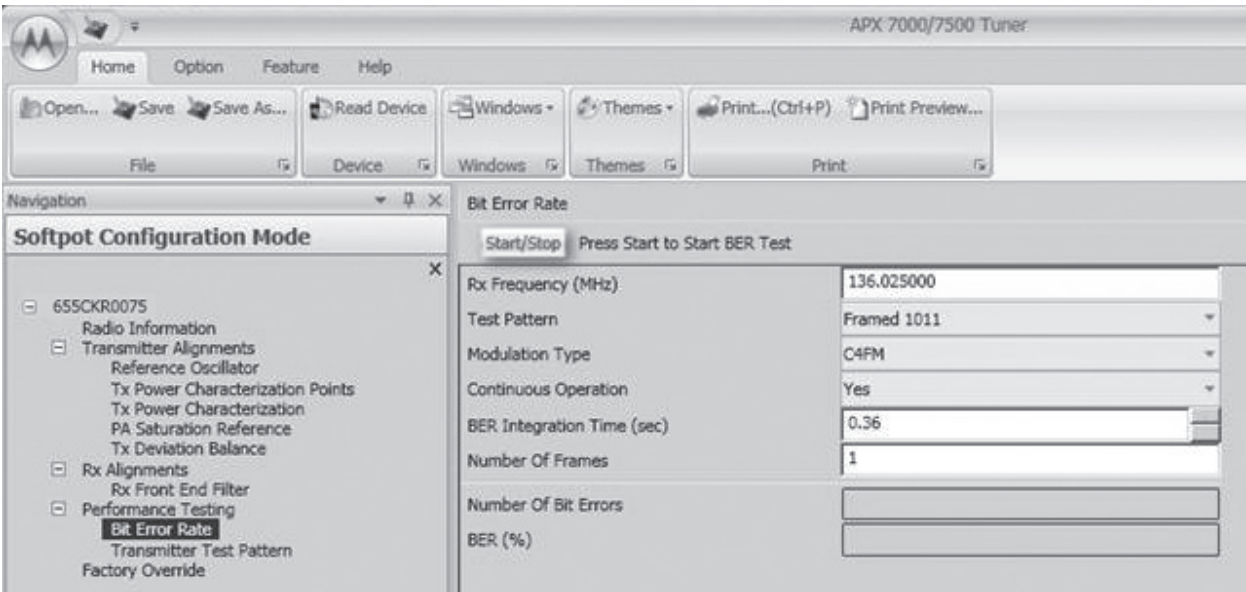

Figure 6-34. Bit Error Rate Screen

3. Press **Start/Stop** button to begin or end BER testing.

## 6.7.2 Transmitter Test Pattern

The Transmitter Test Pattern test is used to transmit specific test patterns at a desired frequency so that the user can perform tests on the radio's transmitter (see [Figure 6-35](#)).

### 6.7.2.1 Transmitter Test Fields

This screen contains the following fields:

- **Tx Frequency:**  
This field selects the Transmit Frequency directly in MHz.
- **Channel Spacing:**  
This field allows the user to select the desired channel spacing in kHz.
- **Test Pattern Type:**  
This field represents the type of test pattern which will be transmitted by the radio when **PTT TOGGLE** button is pressed.

**NOTE:** Channel Spacing and Test Pattern Type fields will be grayed out while radio is transmitting.

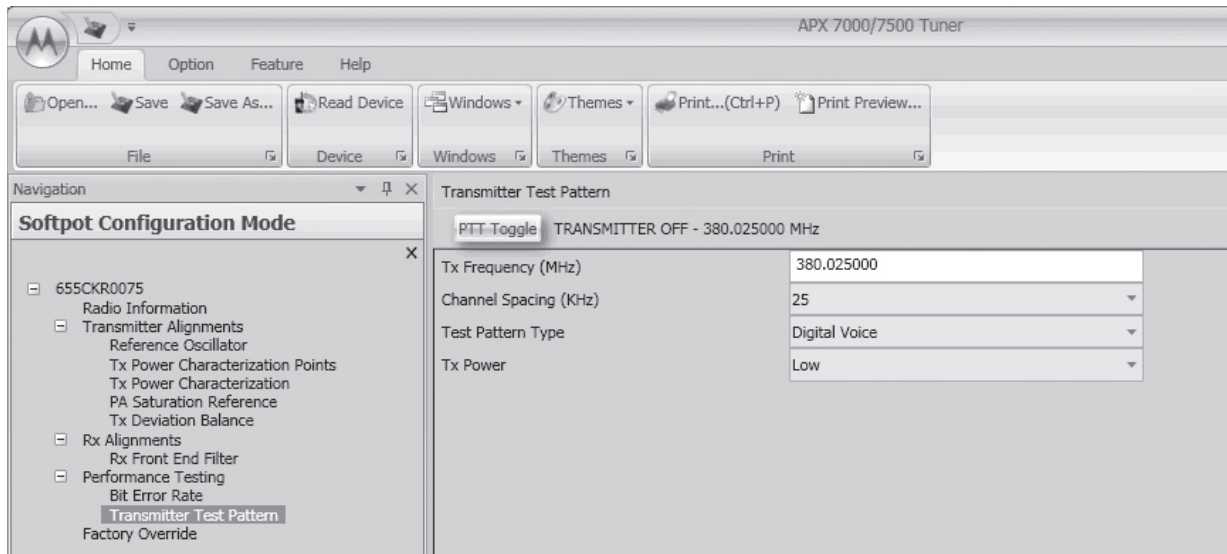

Figure 6-35. Transmitter Test Pattern Screen

---

# Chapter 7 Encryption

This chapter provides procedures for using the encryption capability of your radio. The following procedures are outlined:

- Loading an encryption key
- Selecting an encryption key
- Selecting an Index (only applicable to Dual Display configured radios)
- Erasing an encryption key (only applicable to Dual Display configured radios)

## 7.1 Load an Encryption Key

Keys will be loaded from the KVL to the radio in either clear or encrypted form depending on the configuration of the CPS parameter "KVL – FIPS Level 3 Approved Mode". If the parameter is disabled, keys will be sent in clear form; if the parameter is enabled, keys will be sent to the radio in encrypted form.

**NOTE:** A KVL4000 or KVL3000 Plus with software version R03.52.45 or greater must be used to load keys to a radio with "KVL – FIPS Level 3 Approved Mode" enabled.

To load an encryption key:

1. Refer to the key-variable loader (KVL) manual for equipment connections and setup.
2. Attach the KVL to the radio. The top display shows "KEYLOAD" whereas "KEYLOADING" is shown on the front display of a Dual Display configured radio. All other radio functions, except for power down, backlight, and volume, are locked out.
3. Refer to the KVL manual for how to load the encryption keys into the radio.
4. When the key is loaded successfully, you will hear:
  - On single-key radios – a short tone.
  - On multikey radios – an alternating tone.

## 7.2 Multikey Feature

This feature allows the radio to be equipped with multiple encryption keys. It can support two or more encryption algorithms simultaneously (e.g., AES and DES-XL).

- **Conventional Multikey** – The encryption keys can be tied (strapped), on a one-per-channel basis. In addition, the radio can have operator-selectable keys, operator-selectable indices, and operator-selectable key erasure. If talkgroups are enabled in conventional, then the encryption keys are strapped to the talkgroups.
- **Trunked Multikey** – If the radio is used for both conventional and trunked applications, strap the encryption keys for trunking on a per- talkgroup or announcement group basis. In addition, a different key can be strapped to other features; for example, dynamic regrouping, failsoft, or emergency talkgroup. The radio can have operator-selectable key erasure.

## 7.3 Select an Encryption Key

You can select an encryption key using either the menu or the keypad.

### 7.3.1 Use the Menu

To select an encryption key using the menu:

1. Press **▶** until the display shows “KEY”.
2. Press **◀**, **▶**, or **⏏** directly below “KEY”. The display shows the last user-selected and -stored encryption key, as well as the available menu selections.
3. Press **◀** or **▶** to scroll through the list of encryption keys.
 

**NOTE:** If you select an erased key, the display alternates between showing the encryption key and “ERASED KEY”.
4. Press **◀**, **▶**, or **⏏** directly below the desired menu.
  - PSET = selects the preset or default encryption key.
  - SEL = saves the newly selected key and returns to the home display.
5. Press **⏏**, the **PTT** button, or **◀**, **▶**, or **⏏** directly below the ABRT menu, or turn the **16-Position Select** knob to exit this menu.
  - If the selected key is erased, the display shows “KEY FAIL” and the radio sounds a momentary keyfail tone.
  - If the selected key is not allowed, the display shows “ILLEGAL KEY” and the radio sounds a momentary illegal key tone.

### 7.3.2 Use the Keypad

To select an encryption key using the keypad:

1. Press **▶** until the display shows “KEY”.
2. Press **◀**, **▶**, or **⏏** directly below “KEY”. The display shows the last user-selected and stored encryption key, as well as the available menu selections.
3. Using the keypad, enter the number of the desired key.
 

**NOTE:** If you select an erased key, the display alternates between showing the encryption key and “ERASED KEY”.
4. Press **◀** or **▶** to select from the menu.
  - PSET = selects the preset or default encryption key.
  - SEL = saves the newly selected key and returns to the home display.
5. Press **⏏**, the **PTT** button, or **◀**, **▶**, or **⏏** directly below the ABRT menu, or turn the **16-Position Select** knob to exit this menu.
  - If the selected key is erased, the display shows “KEY FAIL” and the radio sounds a momentary keyfail tone.
  - If the selected key is not allowed, the display shows “ILLEGAL KEY” and the radio sounds a momentary illegal key tone.



## 7.4 Select an Encryption Index

This feature lets the user select one or more groups of several encryption keys from among the available keys stored in the radio. For example, the radio could have a group of three keys structured to one index, and another group of three different keys structured to another index. Changing indices makes the radio automatically switch from one set of keys to the other. Every channel to which one of the original keys was tied will now have the equivalent new key instead.

### 7.4.1 Use the Menu

To select an index using the menu:

1. Press **▶** until the display shows “INDX”.
2. Press **◀**, **▶**, or **⏏** directly below “INDX”. The display shows the last user-selected and -stored index, as well as the available index menu selections.
3. Press **◀**, **▶**, or **⏏** directly below the desired index. The display shows the last user- selected and -stored index, as well as the available index menu selections.
4. Choose one of the following:
  - a. To save the index, press **◀**, **▶**, or **⏏** directly below “SEL”.
  - b. To exit this menu without changing the index selection, press **⏏** or the **PTT** button, or turn the **16-Position Select** knob.

### 7.4.2 Use the Keypad

To select an index using the keypad:

1. Press **▶** until the display shows “INDX”.
2. Press **◀**, **▶**, or **⏏** directly below “INDX”. The display shows the last user-selected and -stored index, as well as the available index menu selections.
3. Using the keypad, enter the number of the desired index.
4. Choose one of the following:
  - a. To save the index, press **◀**, **▶**, or **⏏** directly below “SEL”.
  - b. To exit this menu without changing the index selection, press **⏏** or the **PTT** button, or turn the **16-Position Select** knob.

## 7.5 Erase an Encryption Key

This section describes two methods for erasing an encryption key.

### 7.5.1 Method 1 – Key Zeroization (Multikey Only)

To zeroize an encryption key:





1. Press **▶** until the display shows “ERAS”.
2. Press **◀**, **▶**, or **⏏** directly below “ERAS”. The display shows the last user-selected and -stored encryption key, as well as the available menu selections that are listed in [Table 7-1](#).
3. Choose one of the following:
  - If you want to erase all the encryption keys at once, go to step 4 below.
  - If you want to erase a single encryption key, do one of the following:

- Press ◀ or ▶ to find the desired key. The display shows the selected key and the available menu selections shown in Table 7-1.
- Using the keypad, enter the location number of the desired key. The display shows the selected key, as well as the available menu selections shown in Table 7-1.

Table 7-1. Encryption Key Zeroization Options

Menu Selection	Action
ALL	Erases all the encryption keys in the radio. The display shows "ERS ALL KEYS" and "YES" and "NO".
SNGL	Selects the displayed encryption key to be erased. The display shows "ERS SNGL KEY" and "YES" and "NO".
ABRT	Exits this menu and returns to the home display

**NOTE:** To exit this menu at any time without erasing the key selection, press  or the **PTT** button, or turn the **16-Position Select** knob.

4. Press , , or  directly below the desired menu selection.
5. Press , the **PTT** button, or turn the **16-Position Select** knob to exit this menu.

### 7.5.2 Method 2 – All Keys Erased

To erase all encryption keys at one time:

With the radio on, press and hold the **Top Side** button and, while holding this button down, press the **Top** button.

**NOTE: DO NOT** press the **Top** button before pressing the **Top Side** button unless you are in an emergency situation. This sends an emergency alarm.

Before the keys are erased, the display shows "PLEASE WAIT".

When all the encryption keys have been erased, the display shows "ALL KEYS ERASED".

---

## Chapter 8 Disassembly/Reassembly Procedures

This chapter provides detailed procedures for disassembling/reassembling and ensuring submergibility of the APX 7000XE radios. When performing these procedures, refer to [“Chapter 10: Exploded Views and Parts Lists” on page 2:10-1](#) and the diagrams that accompany the text. Items in parentheses ( ) throughout this chapter refer to item numbers in the exploded view diagrams and their associated parts lists.

This chapter also has procedures for removing and installing the APX 7000XE radio’s standard accessories and changing the Volume and Frequency Knobs.

### 8.1 APX 7000XE Exploded View (Main Subassemblies)

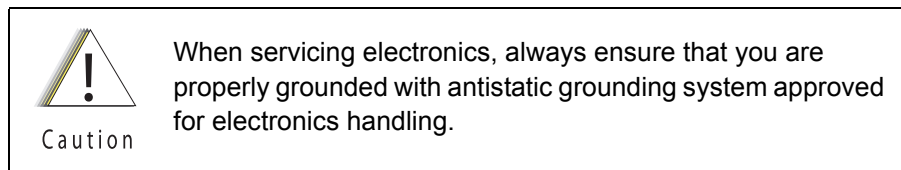

This section contains the APX 7000XE radio partially exploded views.

**NOTES:**

- Refer to [Figure 8-1](#) and [Figure 8-2](#), the Top Display and Dual Display Partial Exploded Views, and [Table 8-1](#), the Partial Exploded View Parts List.
- Letters in parentheses ( ) refer to item letters in [Figure 8-1](#), [Figure 8-2](#) and [Table 8-1](#).

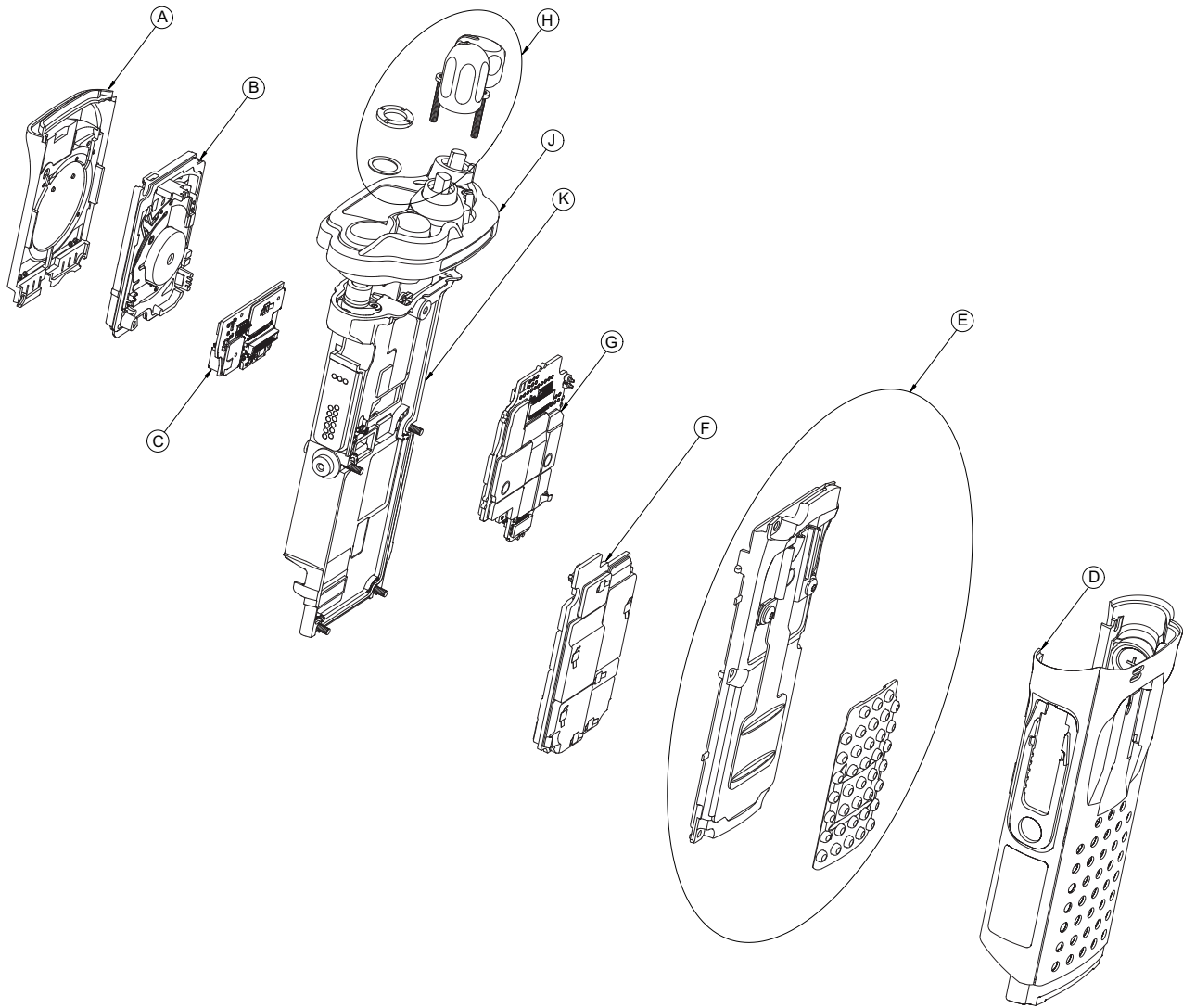
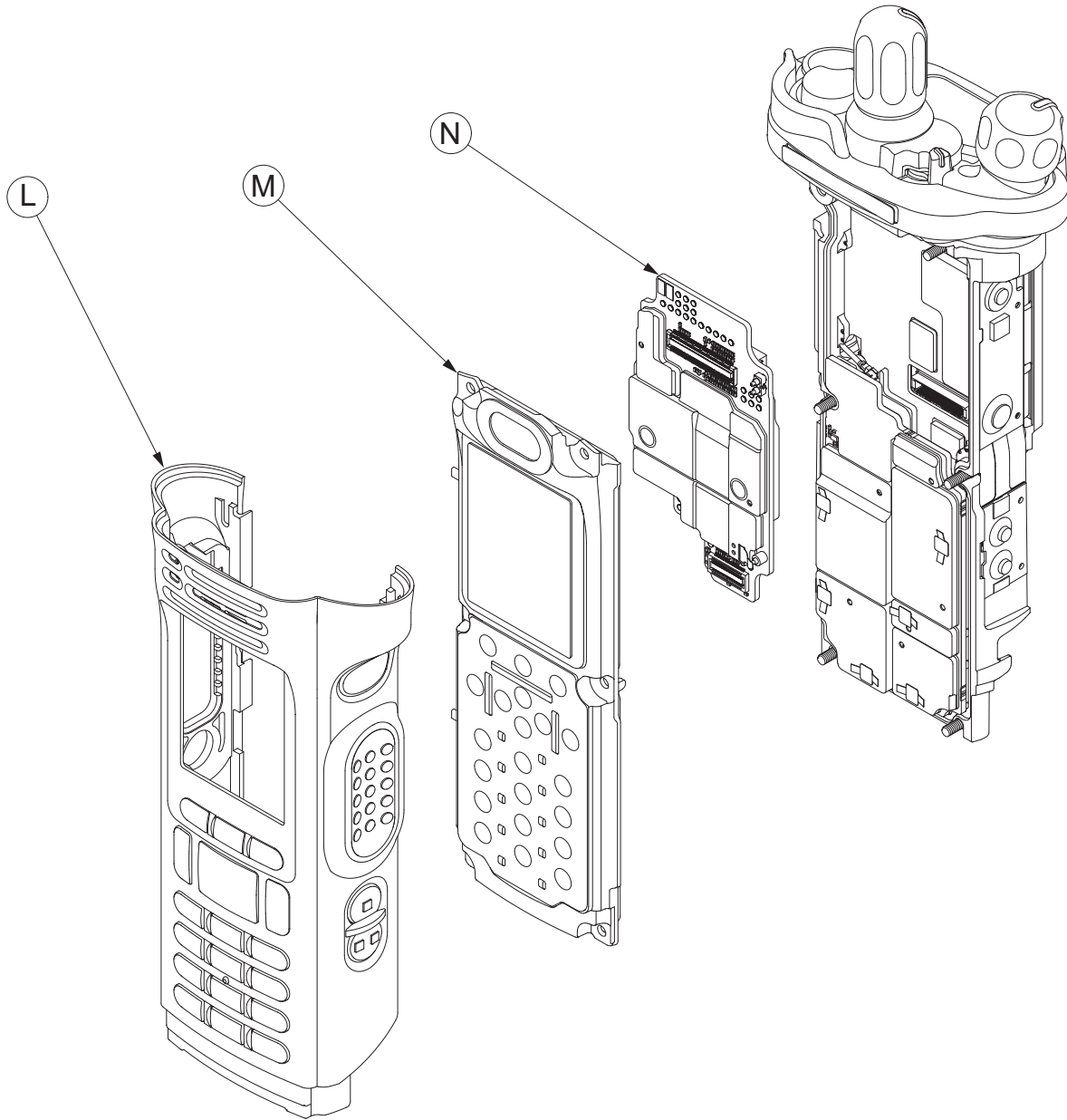

Figure 8-1. APX 7000XE Top Display Partial Exploded View



**NOTE:** All common parts are shown on the APX 7000XE Top Display Partial Exploded View.

*Figure 8-2. APX 7000XE Dual Display Partial Exploded View*

Table 8-1. APX 7000XE Partial Exploded View Parts List

Item Letter	Description	Exploded View and Parts List
A	Speaker Grille Assembly	Refer <a href="#">Figure 10-1: "APX 7000XE Top Display Exploded View"</a> on page 2:10-2.
B	Speaker Module	Refer <a href="#">Figure 10-1: "APX 7000XE Top Display Exploded View"</a> on page 2:10-2.
C	Expansion Board Assembly	Refer <a href="#">Figure 10-1: "APX 7000XE Top Display Exploded View"</a> on page 2:10-2.
D	Main Housing Assembly (Top Display)	Refer <a href="#">Figure 10-1: "APX 7000XE Top Display Exploded View"</a> on page 2:10-2.
E	Back Chassis Assembly (Top Display)	Refer <a href="#">Figure 10-1: "APX 7000XE Top Display Exploded View"</a> on page 2:10-2.
F	RF Board Assembly	Refer <a href="#">Figure 10-1: "APX 7000XE Top Display Exploded View"</a> on page 2:10-2.
G	VOCON Board Assembly (Top Display)	Refer <a href="#">Figure 10-1: "APX 7000XE Top Display Exploded View"</a> on page 2:10-2.
H	Frequency and Volume Knobs Assembly	Refer <a href="#">Figure 10-1: "APX 7000XE Top Display Exploded View"</a> on page 2:10-2.
J	Control Top Assembly	Refer <a href="#">Figure 10-1: "APX 7000XE Top Display Exploded View"</a> on page 2:10-2.
K	Main Chassis Assembly	Refer <a href="#">Figure 10-1: "APX 7000XE Top Display Exploded View"</a> on page 2:10-2.
L	Main Housing Assembly (Dual Display)	Refer <a href="#">Figure 10-2: "APX 7000XE Dual Display Exploded View"</a> on page 2:10-4.
M	Back Chassis Assembly (Dual Display)	Refer <a href="#">Figure 10-2: "APX 7000XE Dual Display Exploded View"</a> on page 2:10-4.
N	VOCON Board Assembly (Dual Display)	Refer <a href="#">Figure 10-2: "APX 7000XE Dual Display Exploded View"</a> on page 2:10-4.
O	Bluetooth Option Board	Refer <a href="#">Figure 10-1: "APX 7000XE Top Display Exploded View"</a> on page 2:10-2.

## 8.2 Required Tools and Supplies

Table 8-2. Required Tools and Supplies

Tools	Motorola Part Number	Supplier	Supplier Part Number	Remarks
Bit, Torx IP8	–	–	–	Torx T8 may be used, but Torx Plus IP8 is recommended
Bit, Antenna Spanner	66009258001	Motorola	–	
Black Stick	–	Hexacon Electric Co.	MA-800G	
Driver, Torque	–	–	–	
Vacuum Pump Kit	NLN9839_	Motorola	–	For Vacuum Test
Grille Eliminator	66009275001	Motorola	–	For Vacuum Test and Pressure Test
Vacuum Adapter	66009259001	Motorola	–	For Vacuum Test and Pressure Test
Pressure Pump Kit	NTN4265_	Motorola	–	For Pressure Test

## 8.3 Fastener Torque Chart

Table 8-3 lists the various fasteners by part number and description, followed by the torque values and the location where used. Torque all fasteners to the recommended value when assembling the radio.

Table 8-3. Required Tools and Supplies

Motorola Part Number	Description	Repair Torque (in-lbs)
0275891B01	Antenna Spanner Nut (16)	16
0375962B01	Top Screw (23)	10
0375962B02	Center Screw (24)	10
0375962B03	Bottom Screw (25)	10
03009357001	Control Top Screw (26)	7

## 8.4 Antenna

This section explains how to attach and remove the antenna.

### 8.4.1 Attach Antenna

To attach the antenna:

With the radio turned off, turn the antenna clockwise to attach it to the radio.

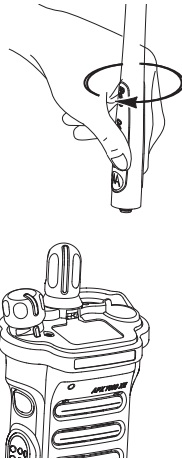

Figure 8-3. Attaching the Antenna

### 8.4.2 Remove Antenna

To remove the antenna:

With the radio turned off, turn the antenna counter-clockwise to remove it from the radio.

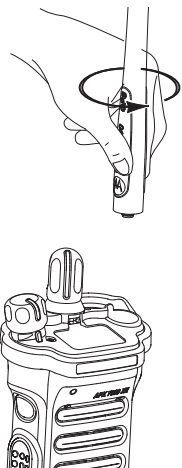

Figure 8-4. Removing the Antenna



## 8.5 Battery

This section explains how to properly attach and remove the battery.



WARNING

**To avoid a possible explosion:**

- **DO NOT** charge, remove, or attach the battery in an area labeled “hazardous atmosphere.”
- **DO NOT** discard batteries in a fire.



Caution

If the radio is programmed for volatile-key retention, encryption keys will be retained for approximately 30 seconds after battery removal.

**NOTE:** The Motorola-approved battery shipped with the APX 7000XE radio is uncharged. Prior to using a new battery, charge it per the recommended procedure for the battery.

### 8.5.1 Attach Battery

To attach the battery:

1. With the radio turned off, verify that the battery seal is set properly in its groove as shown in [Figure 8-5](#).

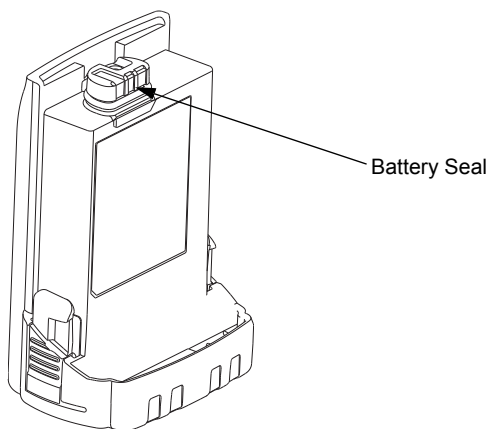

*Figure 8-5. Attaching Battery – Battery Seal*

2. Verify that the Memory Door (28) is closed by ensuring the door is fully seated and the catch feature on the tab is in the main chassis notch.

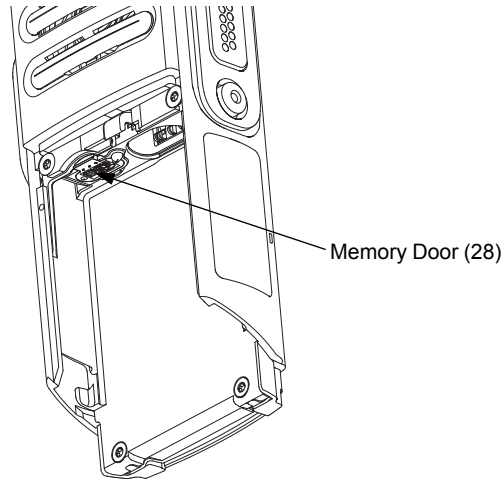

Figure 8-6. Attaching Battery – Memory Door

3. Set the battery onto the chassis as shown in Figure 8-7. and slide into position. Make sure both battery latches click into position.

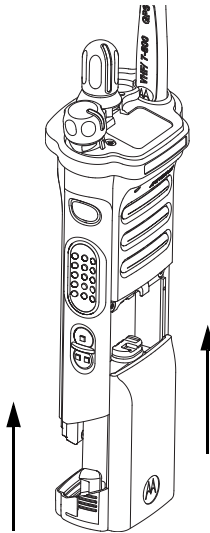
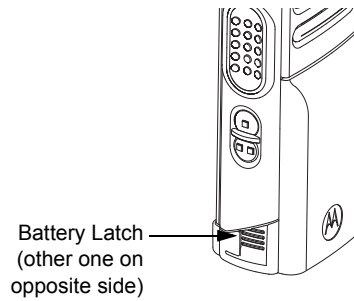

Figure 8-7. Attaching Battery – Slide into Position

## 8.5.2 Remove Battery

To remove the battery:

1. With the radio turned off, squeeze the two latches located near the bottom, on the sides of the battery.



*Figure 8-8. Squeezing the Release Latches*

2. While squeezing the latches, remove the battery by sliding it out as shown.

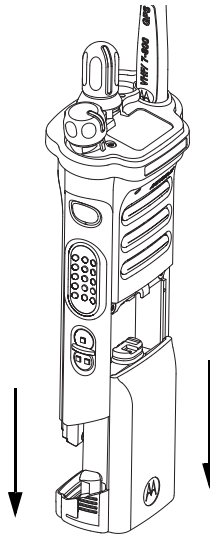

*Figure 8-9. Removing the Battery*

## 8.6 Universal Connector Cover

This section explains how to remove and attach the Universal Connector Cover (38).

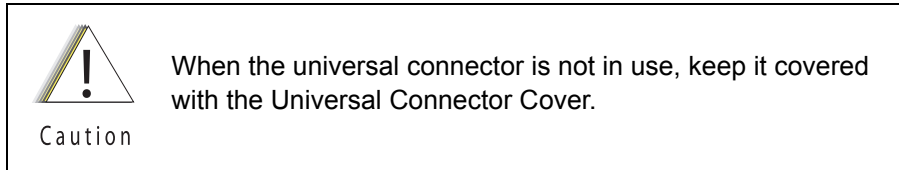

### 8.6.1 Remove Universal Connector Cover

To remove the Universal Connector Cover (38):

1. Unscrew the thumb screw. If the screw is too tight a hex driver may be used.

**NOTE:** Do not remove the screw. It should remain captive in the cover.

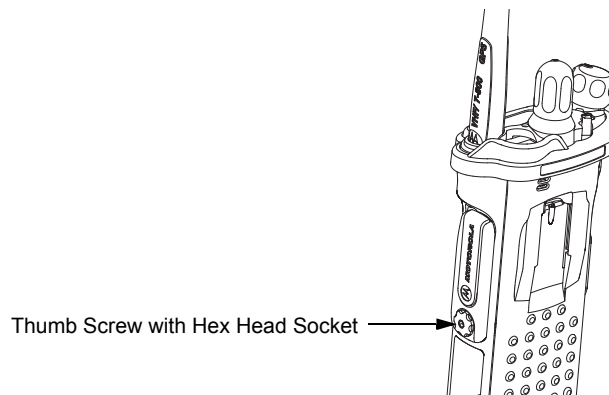

*Figure 8-10. Removing the Thumb Screw*

2. Slightly swing the Universal Connector Cover away from radio before sliding it upward to disengage the hook feature.
3. Pull the Universal Connector Cover away from the radio.

## 8.6.2 Attach Universal Connector Cover

To attach the Universal Connector Cover:

1. Insert the hooked end of the cover into the pocket. Engage the hook beneath the undercut and swing the cover down onto the radio. Ensure the cover is seated properly and the screw is aligned into the threaded hole.

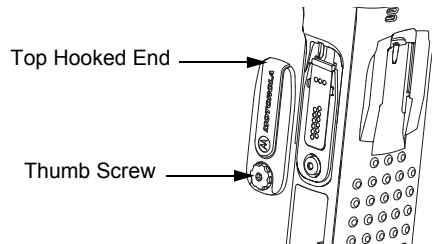

*Figure 8-11. Engaging Hook and Seating Cover*

2. Hand tighten the thumb screw clockwise until secured.

**NOTE:** Do not overtighten the screw. The screw should be snugged and not allow the cover to move.

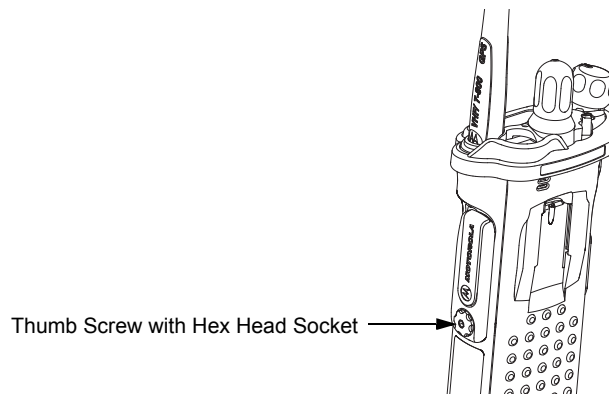

*Figure 8-12. Securing the Cover*

## 8.7 Radio Disassembly

This section contains instructions for disassembling the radio's main subassemblies.

### Prepare the radio for disassembly:

- Turn off the radio by rotating the On/Off/Volume Knob (12) fully counterclockwise until a click is heard.
- Remove the antenna, the battery, any memory card, Belt Clip Cover (39), the Universal Connector Cover (38) and any other accessory connected to the radio.

### 8.7.1 Removal of the Speaker Grille Assemblies (A)

1. With the Battery removed and the primary loudspeaker side of the radio facing you, remove the center two screws (24) and swing out Speaker Grille Assembly (A) as shown in [Figure 8-13](#).

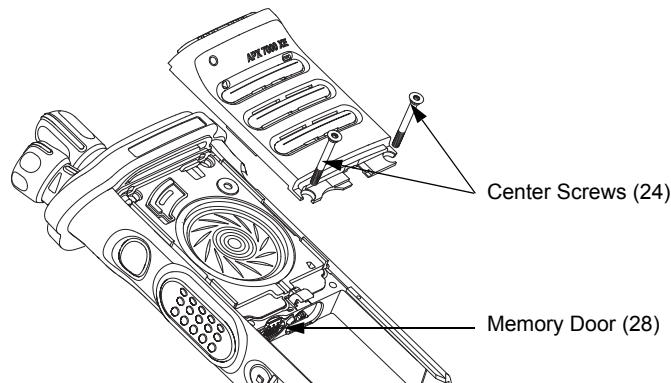

Figure 8-13. Remove Center Screws

**NOTE:** Memory Door (28) can be removed with the left center screw removed.

2. Remove the bottom two screws (25) if the Main Housing Assembly (D, L) is to be removed. Refer [Figure 8-14](#).

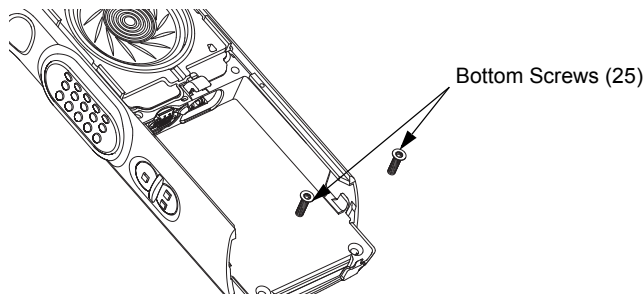

Figure 8-14. Remove Bottom Screws

**NOTE:** Once the screws have been removed, both Thermal Pads (33, 34) should be replaced.



Caution

Do not touch either the speaker cone or the Port Seal (20). Take extra precaution to make sure neither the speaker nor the breather pad is damaged.

## 8.7.2 Removal of the Speaker Module (B)

1. Remove the top two screws (23) as shown in [Figure 8-15](#).

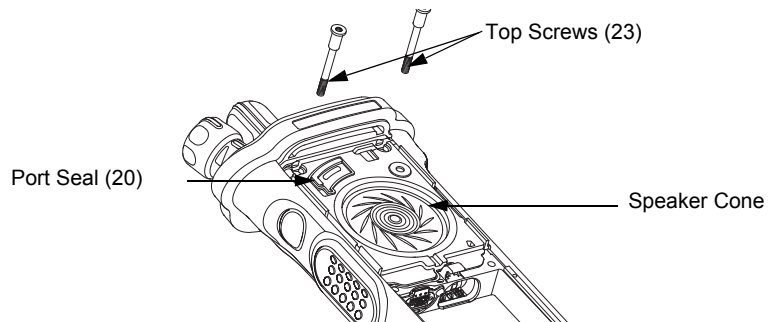

Figure 8-15. Remove Top Screws

2. Carefully pick out the Speaker Module (18) with the Black Stick and swing it out of the Main Chassis Assembly (N) as shown in [Figure 8-16](#).

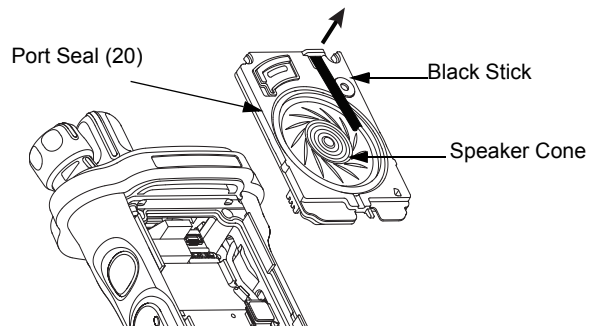

Figure 8-16. Remove Speaker Module



Caution

Be careful not to damage the speaker cone or the Port Seal (20) during the disassembly process.

This Module has lubricant on the seal and can be contaminated with foreign material. Any foreign material can put the radio's submergibility at risk.

### 8.7.3 Removal of the Expansion Board Assembly (C)

- Using the Black Stick, unplug the two flex connectors located on the left and right side of the Expansion Board Assembly (36). Unfold and straighten the flex located on the right side as shown in [Figure 8-17](#).

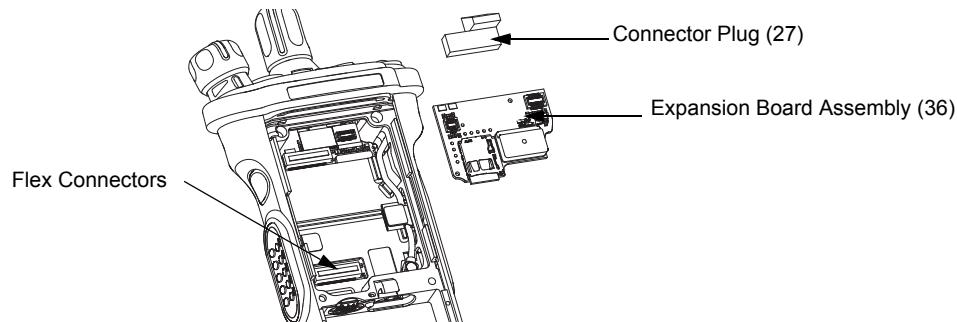
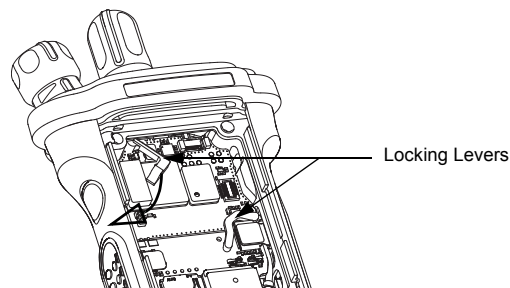

*Figure 8-17. Remove Flex Connectors and Expansion Board Assembly*

- Remove the Expansion Board Assembly (C) by gently lifting up the right side of the PCB as shown in [Figure 8-17](#).
- If the VOCON Board Assembly (G, N) is to be removed from the Control Top Assembly (J), then remove the Connector Plug (27) with the Black Stick and unplug the Control Top Assembly flex as shown in [Figure 8-17](#).

If the radio is equipped with an Bluetooth Option Board Assembly in lieu of the Connector Plug (27):

- rotate the Bluetooth Option Board locking levers to unlock the option board and free it for removal as shown in [Figure 8-18](#).



*Figure 8-18. Unlock Levers*

- unplug the Bluetooth Option Board Assembly from the VOCON Board Assembly by using the Black Stick as shown in [Figure 8-19](#).

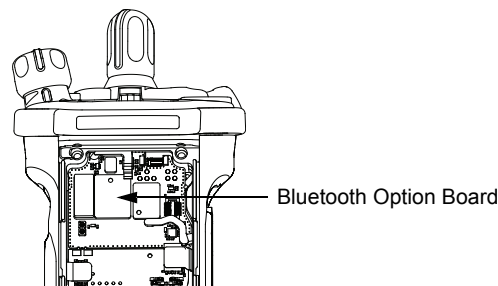

*Figure 8-19. Remove Bluetooth Option Board*



4. If the RF Board Assembly (F) is to be removed, use the Black Stick to unplug the antenna coax cable from the RF Board Assembly as shown in [Figure 8-20](#).

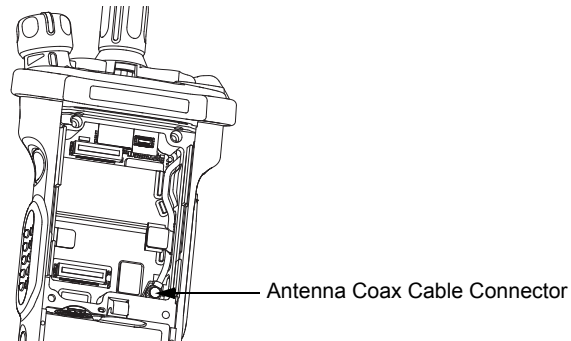

*Figure 8-20. Remove Antenna Coax Cable Connector*

5. Flip the radio over.

#### 8.7.4 Removal of the Main Housing Assembly (D)

- Gently stretch both sides of the Main Housing Assembly (1) outwards to clear the radio. Then, lift it over the radio as shown in [Figure 8-21](#).

**NOTE:** For Top Display version, ensure the Belt Clip Cover (39) has been removed.

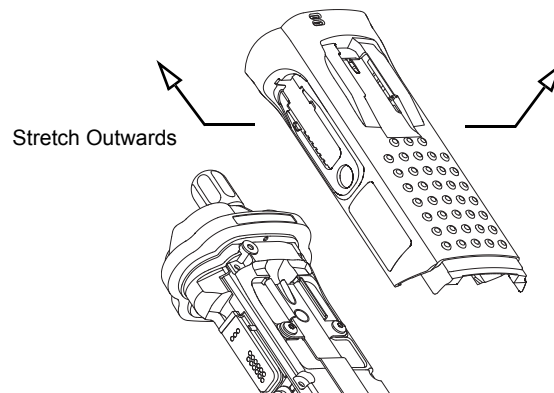

*Figure 8-21. Remove Housing*

### 8.7.5 Removal of the Back Chassis Assembly (E, M)

1. Dual Display version:

Gently separate the Back Chassis Assembly (M) from the Main Chassis Assembly (K) to allow access to disconnect the flex connection between both chassis. This connector is located near the top of the radio. Use the Black Stick to disconnect the connector as shown in [Figure 8-22](#).

Top Display version:

Back Chassis Assembly (E) has no connections and can be removed by just separating the the two chassis apart.

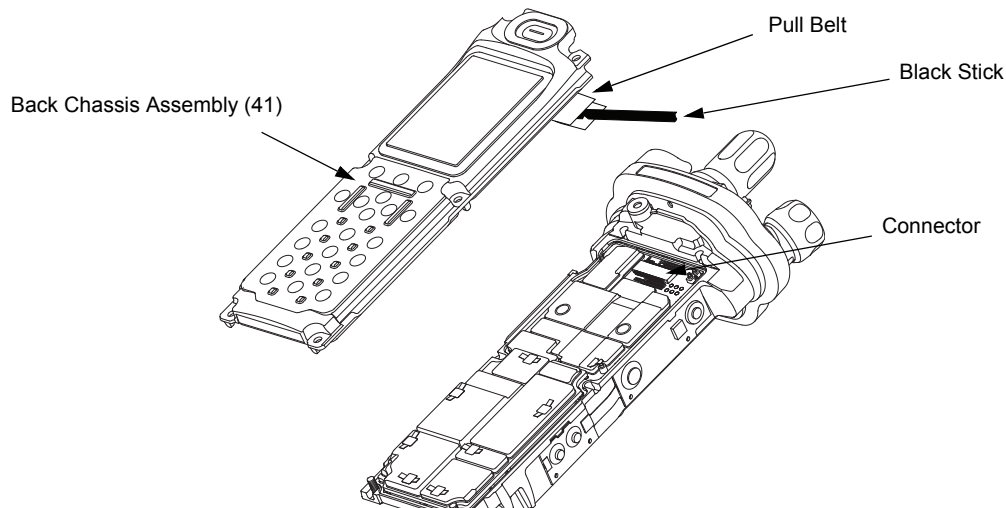
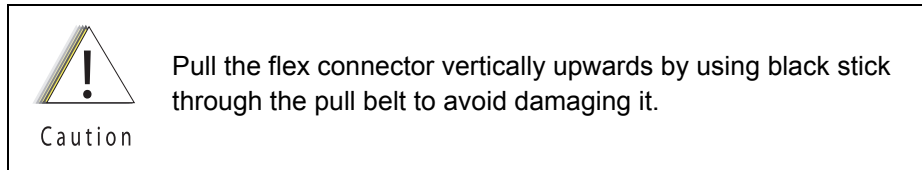

Figure 8-22. Remove Back Chassis Assembly from Main Chassis Assembly

### 8.7.6 Removal of the RF Board Assembly (F)

**NOTE:** Reconfirm the coax cable connector on the bottom side of the RF Board is disconnected before removing the RF Board.

1. Unplug the RF Board Assembly (F) from the VOCON Board Assembly (G, N) by using the Black Stick. Slowly lift the RF Board Assembly enough to allow access to the small coax cable. Unplug the small coax cable using a Black Stick or a pair of small tweezers.



Caution

Place the RF Board Assembly in a clean and ESD safe area to avoid contamination to the Battery Connector Seal (35) and electrical damage to the electronics respectively.

Replace Thermal Pads (33, 34) whenever RF Board Assembly is removed.

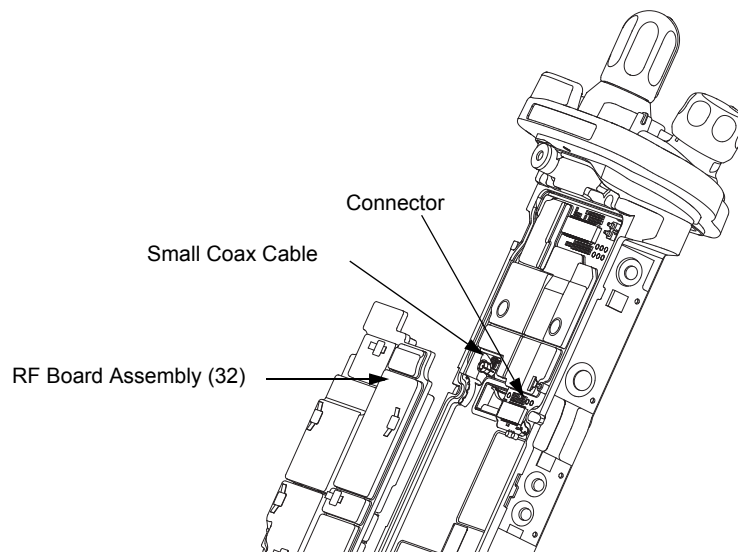
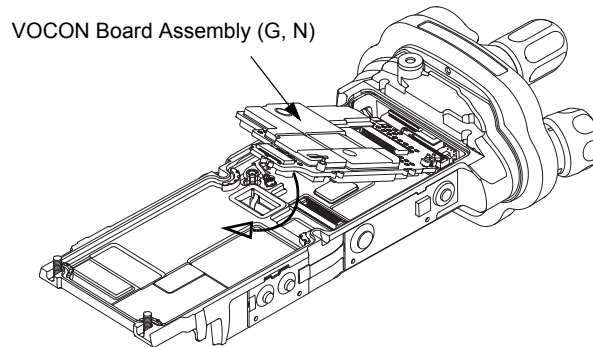

Figure 8-23. Remove RF Board Assembly

### 8.7.7 Removal of the VOCON Board Assembly (G,M)

**NOTE:** Reconfirm the Flex connector between the Control Top Assembly (J) and the VOCON Board Assembly (G, N) or, if so equipped, the Bluetooth Option Board is disconnected (see [step 2 on page 2:8-34](#)). Failure to do so may damage the connectors or the flex.

1. Gently rotate the VOCON Board Assembly just enough to clear the Main Chassis and Bluetooth Option Board connector. Slide out the VOCON Board Assembly as shown in [Figure 8-24](#).



*Figure 8-24. Remove VOCON Board Assembly*

### 8.7.8 Removal of the Knobs

#### A. Remove the Frequency Knob

To remove the Frequency Knob (13):

1. Hold the radio in one hand so that the top of the radio faces upward, and the front of the radio faces you.
2. With a pair of pliers, grasp the Frequency Knob and pull it upward, until it is free from its shaft.

#### B. Remove the Volume Knob

To remove the Volume Knob (12):

1. Hold the radio in one hand so that the top of the radio faces upward and the front of the radio faces you.
2. With a pair of pliers, grasp the Volume Knob and pull it upward.

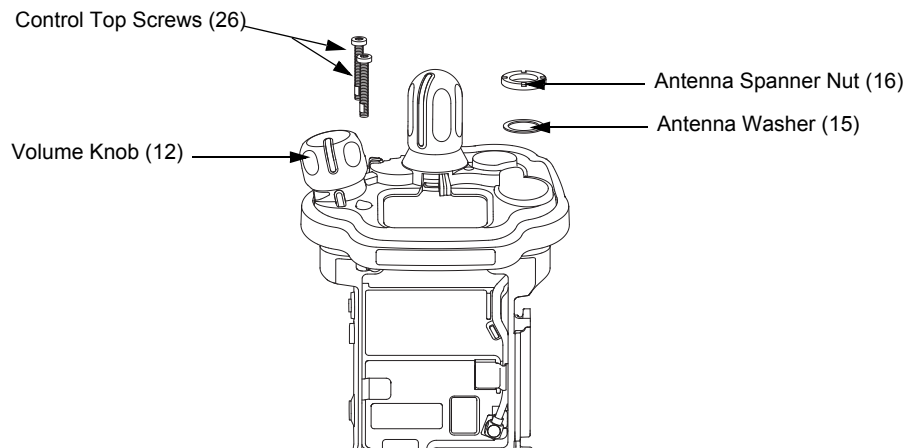

Figure 8-25. Remove Knobs and Fastener Hardware

### 8.7.9 Removal of the Control Top Assembly (J)

- i. Use a Torx Plus IP8 bit to remove the two Control Top Screws (26). See [Figure 8-26](#).

**NOTE:** Ensure the Control Top flex is disconnected from the VOCON Board (G, N) to prevent damage to the flex or connector.

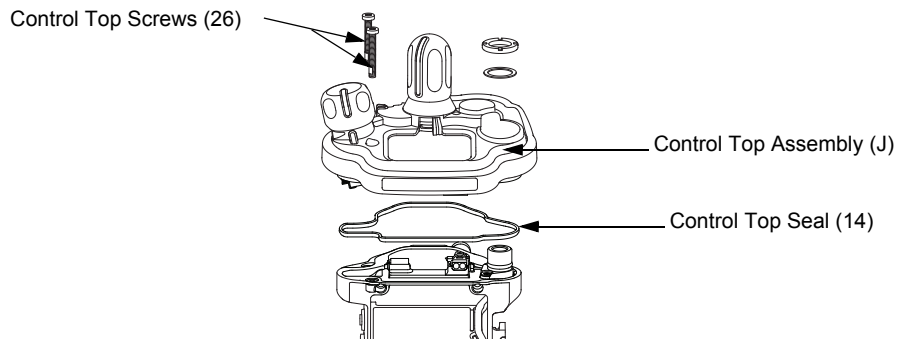

Figure 8-26. Remove Control Top Assembly

- II. Gently separate the Control Top Assembly (J) from the Main Chassis Assembly (K).

**NOTE:** Place the Control Top Assembly (J) and the remaining Main Chassis Assembly (K) on an ESD safe surface free from debris.

## 8.8 Serviceable Components of the Main Sub-Assemblies

### 8.8.1 Servicing Main Chassis Assembly (K)

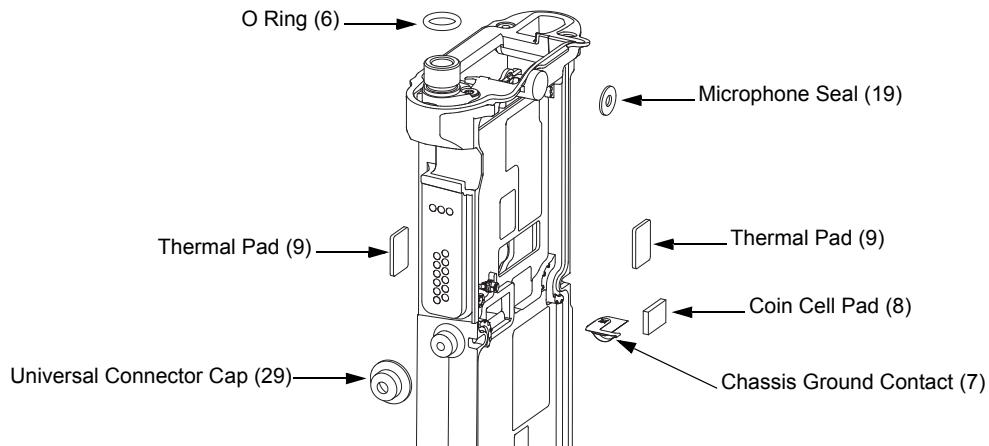

Figure 8-27. Serviceable Components – Main Chassis Assembly

#### 8.8.1.1 Servicing Chassis Pads:

1. Complete steps from [Section 8.7.1.](#) through [Section 8.7.9.](#) of [Section “8.7 Radio Disassembly” on page 2:8-12.](#)
2. Carefully peel off the pad(s) that need replacing (i.e. VOCON Pad (9), Expansion Board Pad (9) and/or Coin Cell Pad (8)) from the chassis.
3. Use the Black Stick to help remove any difficult sections of the pad(s).
4. Clean the area once the pad(s) are removed to ensure it is free of adhesive and debris.
5. Peel the liner off the new pad(s) and place in the respective location.
6. Apply slight pressure to set the adhesive.

#### 8.8.1.2 Servicing Chassis Screw Boss Cap:

1. Complete steps from [Section 8.7.1.](#) through [Section 8.7.4.](#) of [Section “8.7 Radio Disassembly” on page 2:8-12.](#)
2. Carefully pry off the Universal Connector Cover (38) with the Black Stick from the Main Chassis Assembly (4) as shown in [Figure 8-27.](#)
3. Press the new Cap down onto the boss until it is fully seated.

**NOTE:** There should be no gap between the chassis boss top face and the corresponding interior surface of the cap.

#### 8.8.1.3 Servicing Antenna O-ring:

1. Complete steps from [Section 8.7.1.](#) through [Section 8.7.9.](#) of [Section “8.7 Radio Disassembly” on page 2:8-12.](#)
2. Remove the O-ring (6) with the Black Stick.
3. Reinstall the O-ring by rolling it over the threaded portion of the antenna hub until it sets in its groove.

**NOTE:** Ensure the O-ring is not twisted.

#### 8.8.1.4 Servicing Microphone Membrane

1. Complete steps from [Section 8.7.1.](#) through [Section 8.7.4.](#) of [Section "8.7 Radio Disassembly" on page 2:8-12.](#)
2. Carefully peel off the Microphone Membrane (19) from the Main Chassis Assembly (4).
3. Clean the area, once the Microphone Membrane is removed, to ensure it is free of adhesive and debris. Ensure nothing comes in contact with the microphone while cleaning.
4. Remove the backer from the Microphone Membrane.
5. Carefully place the Microphone Membrane centered on the top surface of the microphone boss area on the Main Chassis. Ensure the membrane is flat with no ripples or folds. Press down firmly, applying 2-3 lbs. of force.

#### 8.8.1.5 Servicing Chassis Ground Contact:

**NOTE:** Chassis Ground Contact (7) will be damaged during disassembly.

1. Complete steps from [Section 8.7.1.](#) through [Section 8.7.9.](#) of [Section "8.7 Radio Disassembly" on page 2:8-12.](#)
2. Slide the Black Stick under the Chassis Ground Contact (7) through the opening on the RF/VOCON PCB side of the radio to lift off the contact.
3. Clean the area once the Chassis Ground Contact is removed to ensure it is free of adhesive and debris.
4. Remove the backer of the Chassis Ground Contact and place it in the appropriate location with a pair of flat tip tweezers by aligning the hole in the Ground Contact with the post located on the chassis. Ensure the Ground Contact is centered in the opening and the outer surface of the Ground Contact is parallel to the area adjacent to it in the chassis as shown in [Figure 8-28.](#)
5. Apply pressure to the adhesive to activate it.

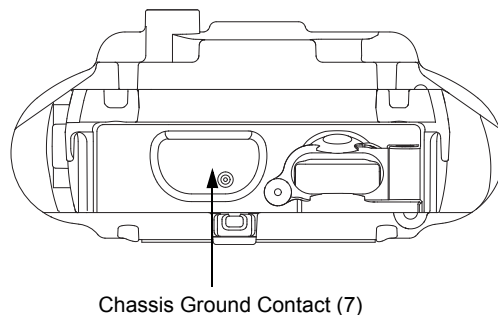

*Figure 8-28. Remove Chassis Ground Contact*

**NOTE:** There are no other serviceable components on the Main Chassis Assembly (N).

## 8.8.2 Servicing Control Top Assembly (J)

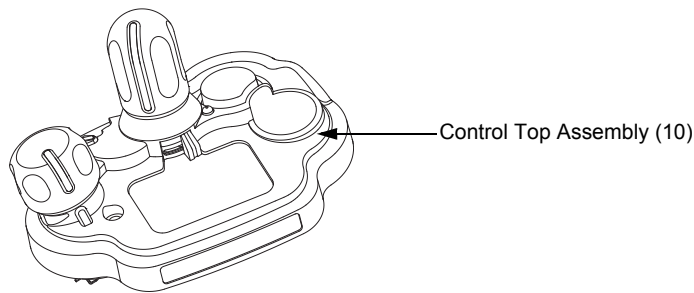

Figure 8-29. Control Top Assembly and Control Top Seal

### 8.8.2.1 Control Top Main Seal

1. Complete steps from [Section 8.7.1.](#) through [Section 8.7.9.](#) of [Section "8.7 Radio Disassembly" on page 2:8-12.](#)
2. Remove the Control Top Seal (14) with the Black Stick.
3. Replace the new seal into the groove provided in the Control Top Assembly's casting.
4. Ensure that seal is set properly and not stretched.

**NOTE:** There are no other serviceable components on the Control Top Assembly (J).

## 8.8.3 Servicing Knobs and Top Bezel Assembly (H)

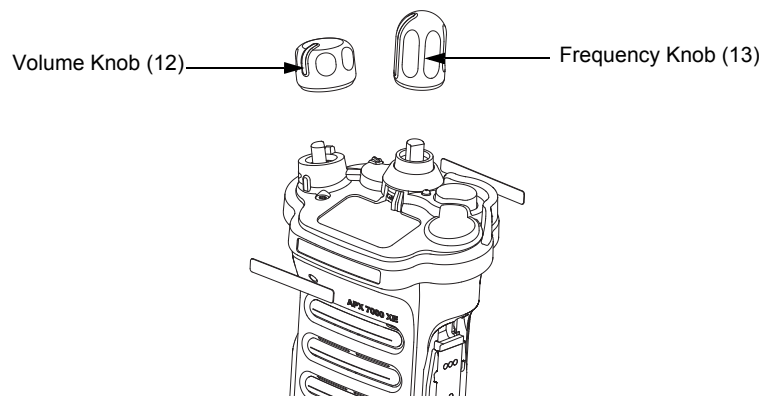

Figure 8-30. Frequency and Volume Knobs Assembly

Knobs should be removed when damaged. To remove knobs:

- Firmly hold the radio in one hand and use a pair of pliers to grip the knob.

**NOTE:** The knobs are designed to be difficult to remove, however, it will come off. If the metal D clip sticks to the knob post, remove the D clip prior to putting on the new knob.



## 8.8.4 Servicing VOCON Board Assembly (G, N)

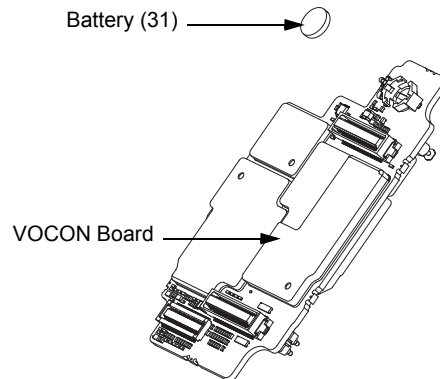

Figure 8-31. VOCON Board Assembly

### 8.8.4.1 Back up Battery

1. Complete steps from [Section 8.7.1](#) through [Section 8.7.7](#) of [Section "8.7 Radio Disassembly"](#) on page 2:8-12.
2. Remove the battery with the Black Stick.

**NOTE:** Make sure the positive side is facing upwards.

3. Press the new battery into the battery carrier until it is secured and fully snapped into place.

**NOTE:** There are no other serviceable components on the VOCON Board Assembly.

## 8.8.5 Servicing of RF Board Assembly

Complete steps [8.7.1](#) through [8.7.6](#) of [Section "8.7 Radio Disassembly"](#) on page 2:8-12.

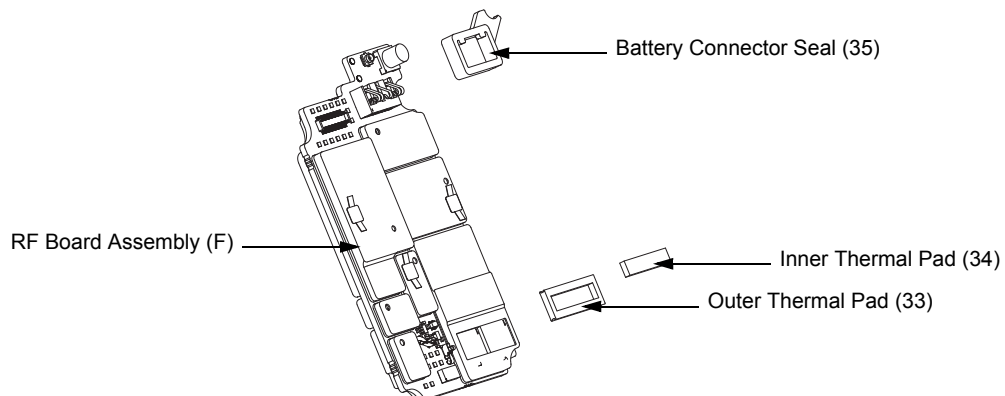

Figure 8-32. RF Board Assembly

### 8.8.5.1 Battery Seal

1. Slide the Battery Connector Seal (35) from the battery contact header with the Black Stick.
2. Use the Black Stick and push the new Battery Connector Seal until it is properly seated onto the RF Board surface.

### 8.8.5.2 Thermal Pads

1. Scrape off both thermal pads (33, 34) from the amplifiers and/or Main chassis with the Black Stick.
2. Ensure there are no debris or residue left on the amplifier's surfaces.
3. Replace with new thermal pads.
4. Peel off the back liner from the thermal pads.
5. Insert the Outer Thermal Pad (33) into the shield opening. Make sure the bottom surface of the pad is mating with the top surface of the amplifiers.
6. Insert the Inner Thermal Pad (34) without compressing or deforming it.

**NOTE:** There are no other serviceable components on the RF Board Assembly.

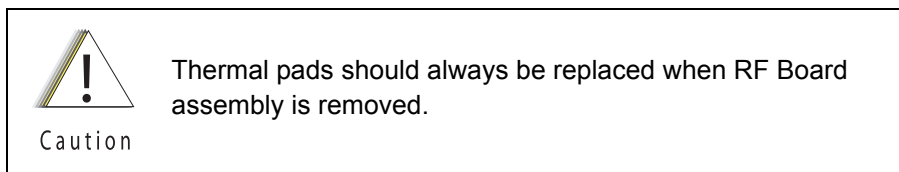

### 8.8.6 Servicing of Expansion Board Assembly

1. Complete steps 8.7.1 through 8.7.3 of [Section "8.7 Radio Disassembly"](#) on page 2:8-12.

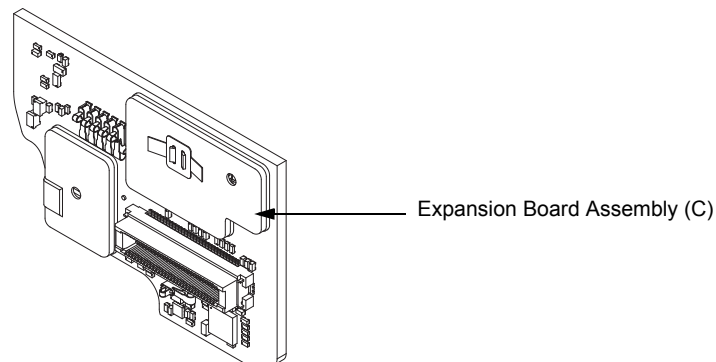

*Figure 8-33. Expansion Board Assembly*

**NOTE:** There are no serviceable components on the Expansion Board Assembly.

## 8.8.7 Servicing Back Chassis Assembly (M) – Dual Display Version

Complete steps 8.7.1 through 8.7.5 of Section “8.7 Radio Disassembly” on page 2:8-12

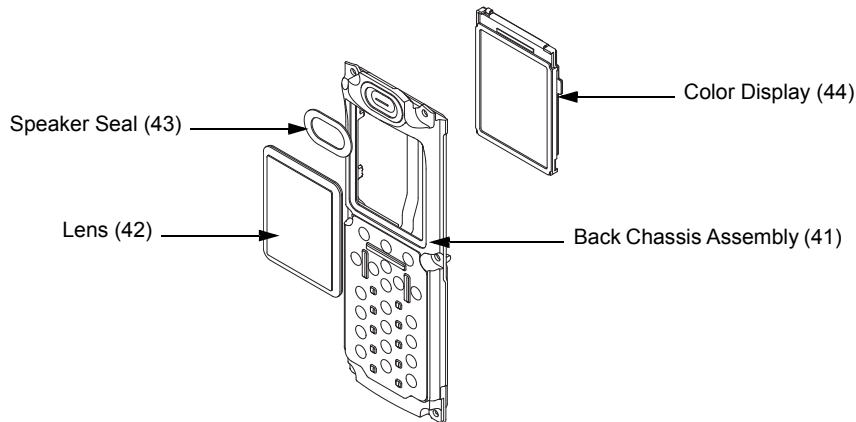

Figure 8-34. Back Chassis Assembly (Dual Display Version)

**NOTE:** Take care not to damage the Color Display during disassembly.

### 8.8.7.1 Servicing Color Display

1. Disconnect the Back Chassis Flex from the back of the Color Display (44).
2. Gently pry the Color Display out of the Back Chassis Assembly (41) by using the Black Stick against the white section of the frame (upper left corner at the back of the Color Display).



Caution

Take care not to damage the Back Chassis seal while servicing the Back Chassis.

3. Remove any remnants of the Display's Pad if it does not come off completely with the Color Display from the back Chassis Assembly.
4. Clean the area to ensure it is free of adhesive and debris once the Display is completely removed.
5. Ensure there are no foreign material on the new Color Display or the Lens (42).
6. Remove the liner from the new Color Display and seat it into the Back Chassis Assembly.
7. Ensure the Display is oriented correctly and seated properly.

### 8.8.7.2 Servicing the main Lens

**NOTE:** Prior to Lens removal, Color Display must be removed (See [Section 8.8.7.1 on page 2:8-25](#)).

1. Remove the main Lens (42) carefully and slowly with the Black Stick.

**NOTE:** To ease the breaking of the adhesive bond, place Back Chassis in freezer.

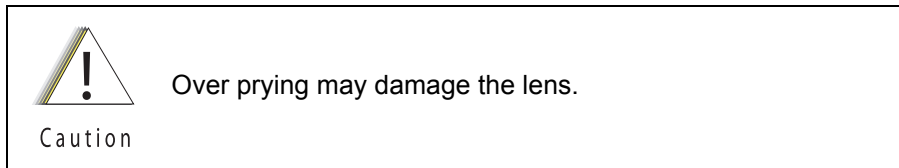

2. Clean the area once the Lens is completely removed to ensure it is free of adhesive and debris.
3. Peel the liner off of the adhesive side of the new Lens and place it centered left to right in the lens pocket of the back Chassis assembly. Bias it upwards against the horizontal surface.
4. Press the Lens down.
5. Ensure the adhesive shows no sign of air entrapments.

### 8.8.7.3 Servicing the Speaker Seal

**NOTE:** Speaker Seal (43) will be damaged during disassembly. Do not reuse.

1. Carefully scrape off the Speaker Seal (43) with the Black Stick without contacting the Speaker.
2. Clean the area once the Speaker Seal is completely removed, to ensure it is free of adhesive and debris.
3. Replace with a new Speaker Seal.
4. Peel the liner off and place the new Seal centered to the speaker and press onto the Back Chassis.

**NOTE:** There are no other serviceable components on the Back Chassis Assembly.

### 8.8.8 Servicing Back Chassis Assembly (E) – Top Display Version

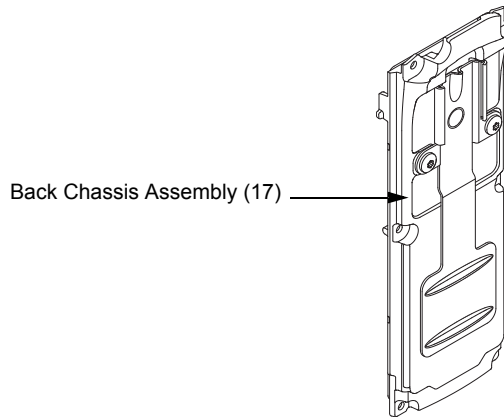

Figure 8-35. Back Chassis Assembly (Top Display Version)

**NOTE:** There are No serviceable Components on the Back Chassis Assembly.

### 8.8.9 Servicing Main Housing (D)/ Main Housing (L)

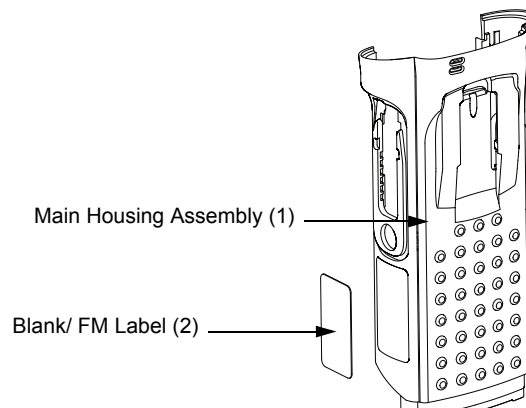

Figure 8-36. Main Housing Assembly

#### 8.8.9.1 Blank/FM Label (2)

**NOTE:** There is no need to remove any components in order to service the Blank/FM Label (2) or FM Label Label (46).

1. Scrape off the Blank/FM Label (2) or FM Label Label (46) with the Black Stick.
2. Clean the area once the label is completely removed to ensure it is free of adhesive and debris.
3. Replace with a new label.
4. Remove the liner and place the label in the recess.
5. Press the label.

**NOTE:** There are No Other serviceable components on the Main Housing Assembly (D)/ Main Housing Assembly (L).

### 8.8.10 Servicing Speaker Module (B)

1. Complete steps 8.7.1 through 8.7.2 of [Section “8.7 Radio Disassembly”](#) on page 2:8-12.

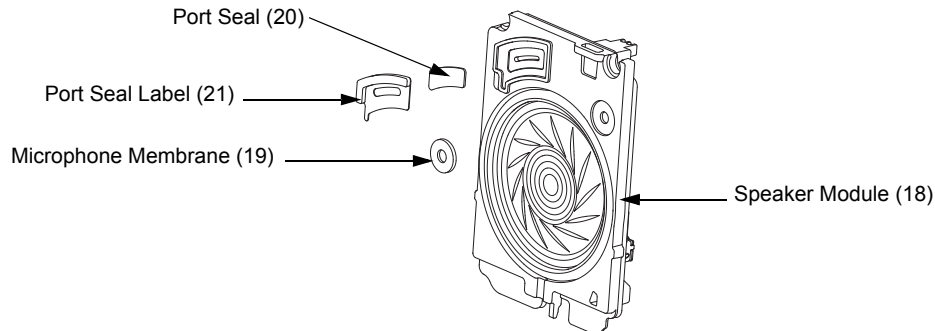

Figure 8-37. Speaker Module

#### 8.8.10.1 Servicing Port Seal and Port Seal Label

**NOTE:** Port Seal (20) and Port Seal Label (21) will be damaged during disassembly.

2. Remove the white Port Seal (20) and the black Port Seal Label (21) with the Black Stick.
3. Lift up the Port Seal Label carefully. Do not scratch the mating surface on the Speaker Module (18).
4. Clean the area once both Seals are removed to ensure it is free of adhesive and debris.
5. Remove the backer of the white Port Seal and place it in the appropriate location on the Speaker Module with a pair of flat tip tweezers. Ensure the seal is flat with no ripples, folds or tears.
6. Remove the backer of the black Port Seal Label and place it in the appropriate location on the Speaker Module with a pair of flat tip tweezers. Ensure the label is flat with no ripples or folds.

#### 8.8.10.2 Servicing Microphone Membrane

**NOTE:** Disassembly the Microphone Membrane will damage it.

2. Carefully peel off the Microphone Membrane (19) from the Speaker Module (18).
3. Clean the area once the Microphone Membrane is removed to ensure it is free of adhesive or debris. Ensure nothing comes in contact with the microphone while cleaning.
4. Remove the backer from the Microphone Membrane.
5. Carefully place the Microphone Membrane within the recess area on the Speaker Module. Ensure the membrane is flat with no ripples or folds.
6. Press down firmly, applying 2-3 lbs. of force.

**NOTE:** There are No Other serviceable components on the Speaker Module (B).

## 8.9 Radio Reassembly

This section contains instructions for reassembling the radio.

### 8.9.1 Reassemble the Main Sub Assemblies

#### 8.9.1.1 Assemble Top Control Assembly (J) to Main Chassis Assembly (N)

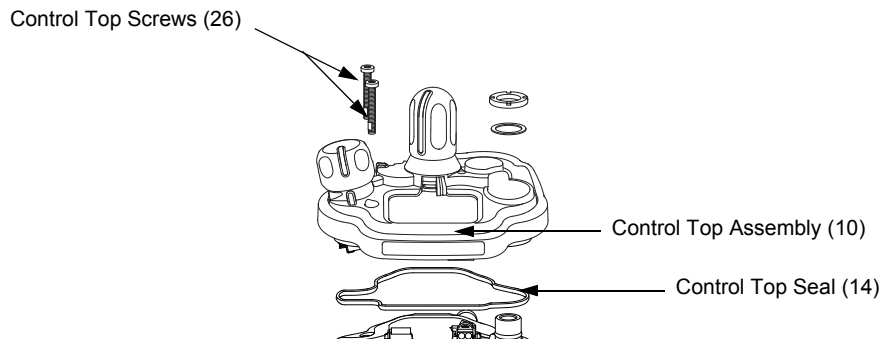

*Figure 8-38. Control Top Bezel Assembly*

1. Verify there are no surface irregularities such as scratches or indentations on both the Control Top Main Seal Groove and the Seal's mating surface on the Main Chassis Assembly (4). Also ensure that the Control Top Seal (14) and surrounding surfaces are free of debris and other foreign material.
2. Verify Control Top Seal is properly seated into its groove and place Control Top Assembly onto Main Chassis Assembly as shown in [Figure 8-38](#).
3. Torque both screws with a Torx IP8 Bit and a torque Driver to 8 in-lbs.

#### 8.9.1.2 Assemble Frequency and Volume Knobs Assembly (H)

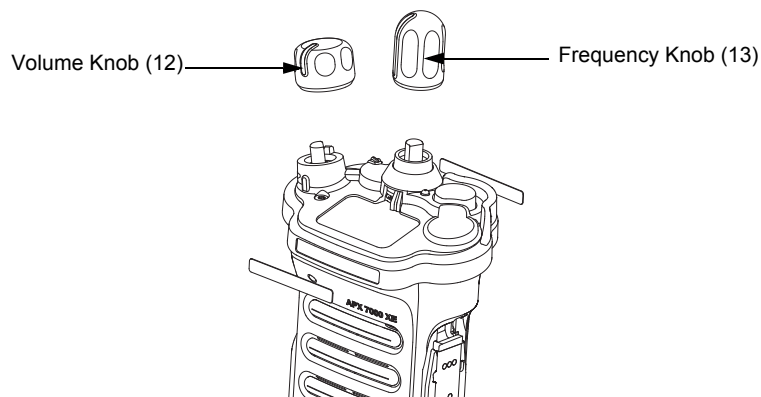

*Figure 8-39. Knobs Assembly*

1. Align the D-shaped part of the Volume Shaft with the D-shape hole in the Volume Knob and press the Volume Knob (12) into place.

- Align the D-shaped part of the Frequency Shaft with the D-shape hole in the Frequency Knob (13) and press the Frequency Knob into place.

**NOTE:** Considerable force is needed to press the knobs into place. The use of a solid surface may be required. If used, the surface should be covered with a rubbery covering to prevent markings on the knobs.

### 8.9.1.3 Assemble VOCON Board Assembly (G, N)

- Inspect the Main Chassis (4) sealing surfaces to make sure there is no surface irregularities such as scratches or indentations. Clean any debris or other foreign material.
- Inspect the two thermal pads (9) on the front and back of the unit along with the Coin Cell Pad (8) to confirm pads are clean and free of debris as shown in [Figure 8-40](#).

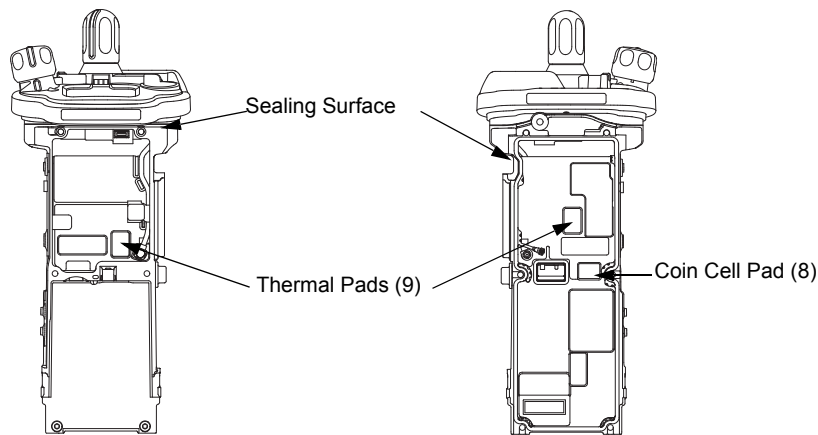

Figure 8-40. Inspect Pads

- Orient the Main Chassis (4) with the Frequency Knob (13) on top. Insert the VOCON Board Assembly (30/ 45) into the chassis starting at a 45° angle and rotate the board into place. Ensure the control top flex is located below the PCB, and is not being pinched between the PCB and the casting. See [Figure 8-41](#).

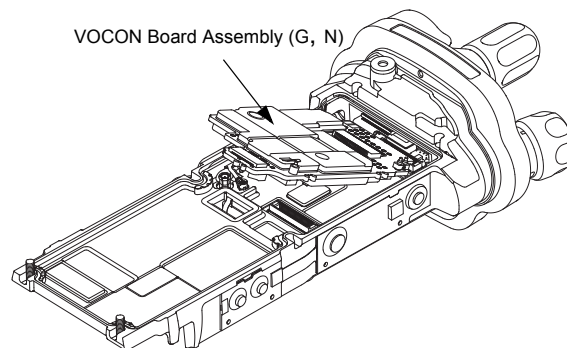

Figure 8-41. Insert VOCON Board



## 8.9.1.4 Assemble RF Board Assembly (F)



Caution

Always replace with new thermal pads. See [Section "8.8.5.2 Thermal Pads"](#) on page 2:8-24.

1. Inspect the Battery Connector Seal (35) on the RF Board Assembly (F) for any damage or debris. Replace seal if necessary.
2. Connect the small coaxial cable connector into the RF Board (32).
3. Connect the RF Board to the VOCON Board as shown in [Figure 8-42](#).

**NOTE:** Do not connect the Antenna coax at this time. Front Housing Assembly (1) must be snapped in place prior to connecting the coax.

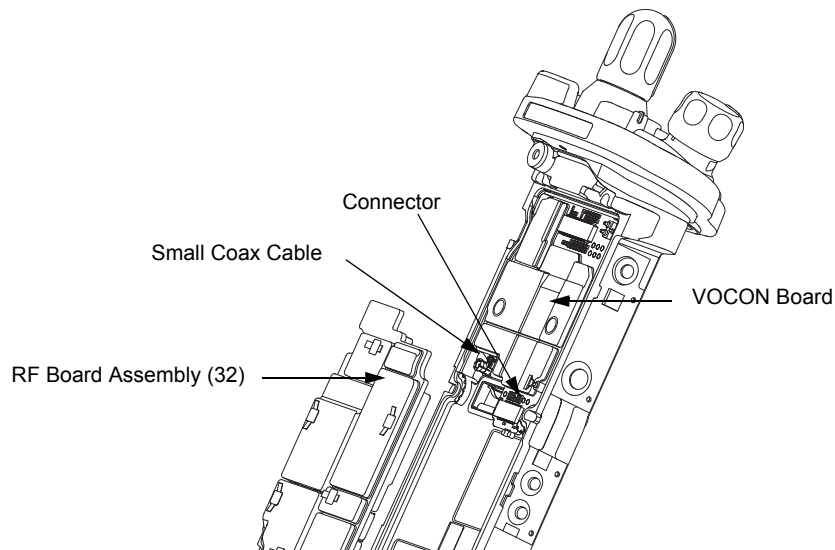

*Figure 8-42. Connect RF Board to VOCON Board*

### 8.9.1.5 Assemble Back Chassis Assembly (E, M)

#### Dual Display version:

1. Inspect the Back Chassis Assembly seal for any debris or foreign material.
2. Connect the Back Chassis Flex to the VOCON board (N).
3. Set the Back Chassis Assembly (M) onto the Main Chassis Assembly (K).

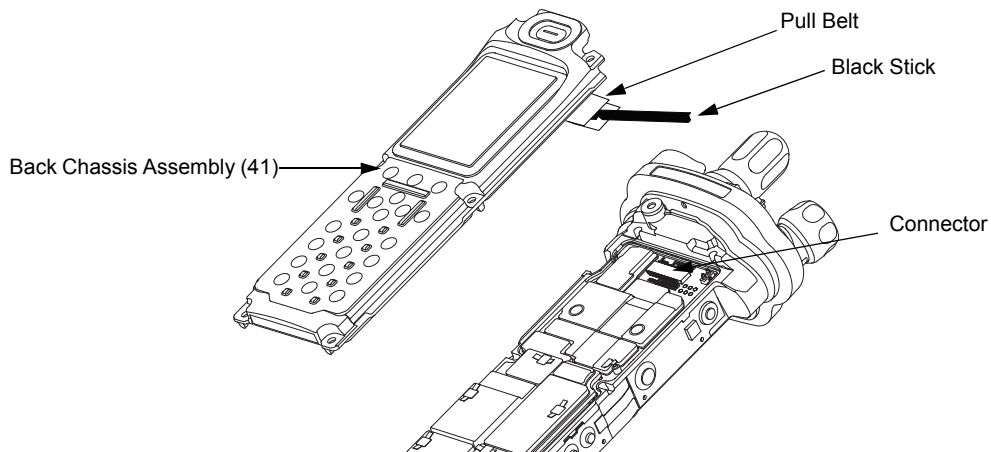

Figure 8-43. Place Back Chassis

#### Top Display version:

1. Inspect the Back Chassis Assembly seal for any debris or foreign material.
2. Set the Back Chassis Assembly (E) onto the Main Chassis Assembly (K).

### 8.9.1.6 Assemble Main Housing Assembly (D, L)

1. Stretch the Main Housing Assembly (D, L) side walls outward with both hands just enough to clear the Main Chassis (K) and place it onto the radio.
2. Ensure the top edge of the housing and the bottom edge of the control top are aligned as shown in [Figure 8-44](#).
3. Squeeze the Main Housing Assembly (D, L) and the Main Chassis Assembly (K) in the battery area until the Main Housing Assembly fully snaps in place onto the Main Chassis Assembly.

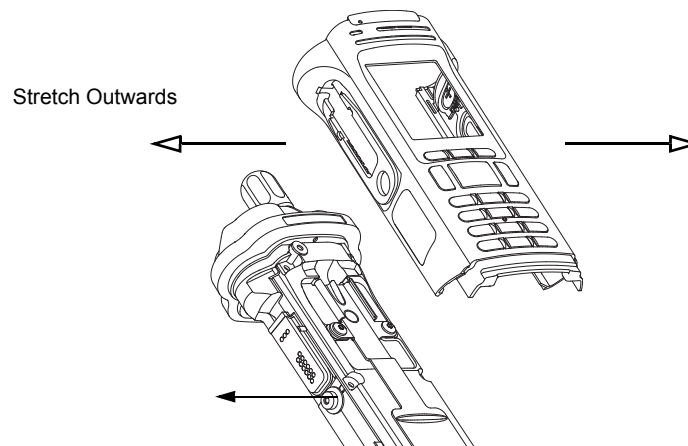
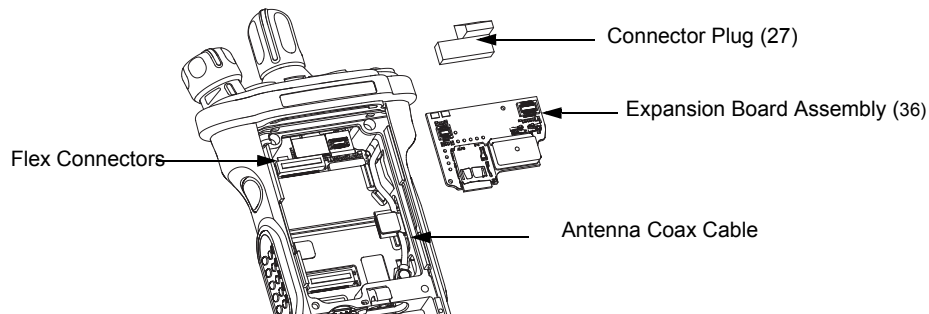

Figure 8-44. Place Housing into Main Chassis

### 8.9.1.7 Assemble Expansion Board Assembly (C)



*Figure 8-45. Assemble Expansion Board Assembly*

1. If the Control Top Assembly (J) or VOCON Board Assembly (G, N) was NOT removed skip to step 2.  
Connect the Control Top Flex to the VOCON Board Assembly as shown in [Figure 8-45](#).
2. If the RF Board Assembly (F) was NOT removed, skip to step 4.  
Carefully align the Antenna Coax Plug to the Coax Receptacle on the RF board Assembly (F) and slide the plug in using the Black Stick. Ensure the universal connector flex is not caught under the antenna coax cable.
3. Tuck in the Antenna Coax Cable into its grooves as shown in [Figure 8-45](#).
4. Plug the Expansion Board Assembly (C) to the VOCON Board Assembly (G, N) as shown in [Figure 8-45](#). Make sure the connector is fully engaged.
5. Connect the two Flex Connectors to their pairing connectors on the right and left sides of the Expansion Board Assembly as shown in [Figure 8-46](#).

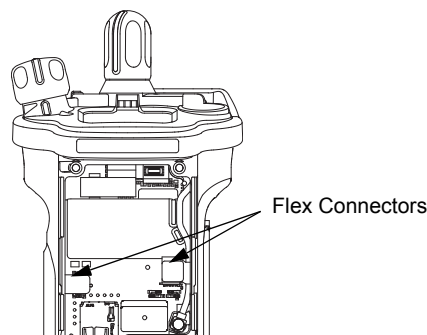
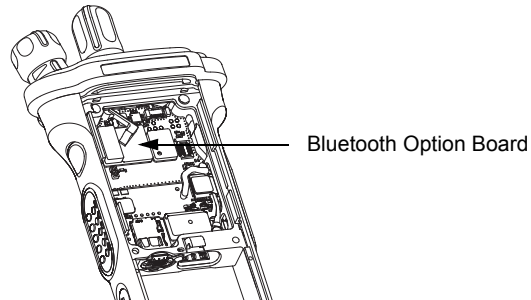

*Figure 8-46. Insert Flex Connectors*

6. If the radio is equipped with an Bluetooth Option Board Assembly skip this step. Install the Connector Plug (27) by inserting it onto the Option Board Connector on the VOCON Board Assembly as shown in [Figure 8-45](#).

### 8.9.1.8 Assemble Bluetooth Option Board Assembly (if so equipped)

1. Connect the Bluetooth Option Board Assembly to the VOCON Board Assembly. Ensure it is completely connected as shown in [Figure 8-47](#).



*Figure 8-47. Assemble Bluetooth Option Board*

2. Rotate the Bluetooth Option Board locking levers till they slide under the chassis feature and lock the option board in place. Levers should be fully rotated until they rest as shown in [Figure 8-48](#).

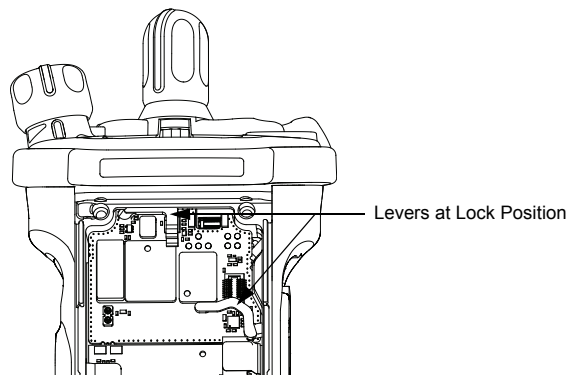

*Figure 8-48. Lock Levers*

## 8.9.1.9 Assemble Speaker Module (B)



Caution

Do not touch the speaker cone or the Port Seal (20). Take extra precaution to make sure neither the speaker nor the breather pad is damaged.

1. Apply a thin film of Lubricant (Part Number 1110027B23) to the upper two corners of the Main Chassis (4) in the Speaker Module (18) opening as shown in [Figure 8-49](#). Ensure no lubricant contaminates the gold pads or the microphone membrane (19).

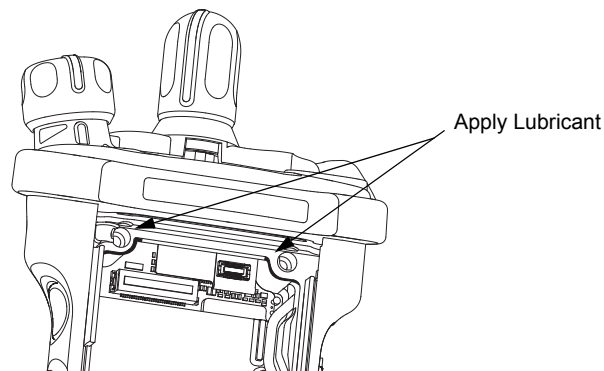

*Figure 8-49. Lubricate Main Chassis*

**NOTE:** Avoid any lubricant to come in contact with any internal components.

2. Ensure the Seal is free from any debris or foreign material.
3. Align the Speaker Module's Pin feature located on the bottom edge directly below the speaker, into the hole on the chassis hook feature.
4. Swing the Speaker Module down and firmly press the top side into the radio as shown in [Figure 8-50](#).

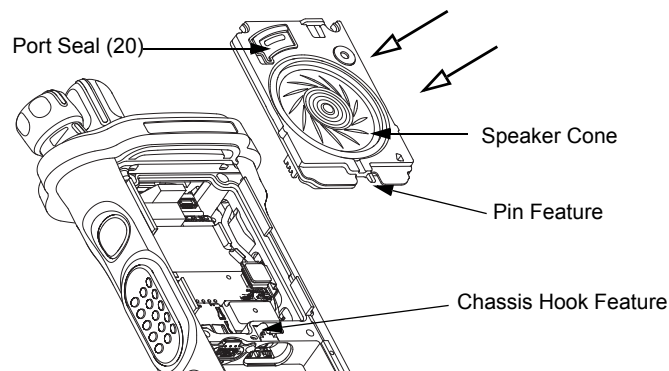

*Figure 8-50. Insert Speaker Module*

5. While holding the Speaker Module down, place the two top screws (23) into their respective holes and torque the screws to 10 in-lbs with an IP8 Torx Bit in a torque driver. See [Figure 8-51](#).

**IMPORTANT:** For proper sealing, Speaker Module (B) must be held down during the torquing of the screws.

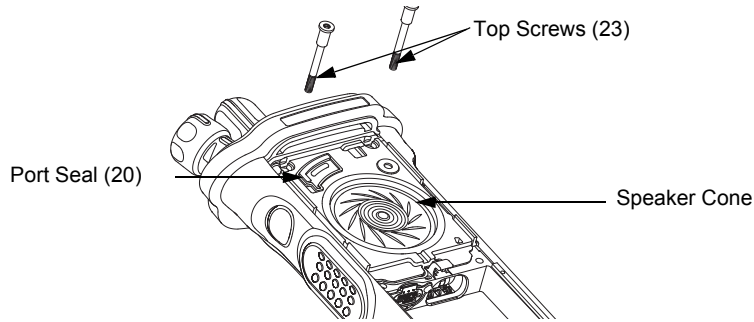

Figure 8-51. Insert Top Screws

### 8.9.1.10 Assemble Speaker Grille Assembly (A)

1. Install the Speaker Grille (A) by inserting the top lip under the control top bezel and rotating the grille into place. See [Figure 8-52](#).

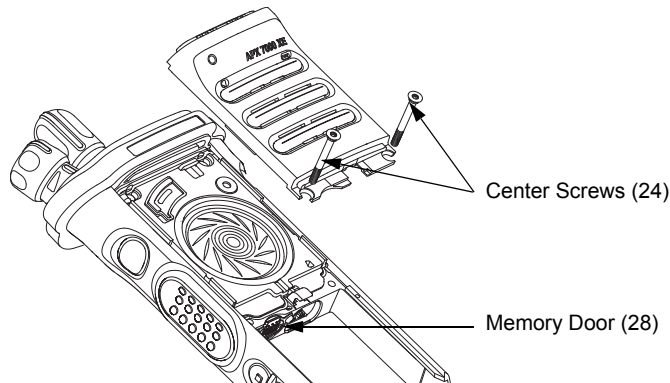

Figure 8-52. Remove Center Screws

**NOTE:** Ensure the Memory Door (28) is in place and the memory door screw shaft is aligned with the screw hole.

2. Insert the two center screws (24) and torque to 10 in-lbs. See [Figure 8-53](#).

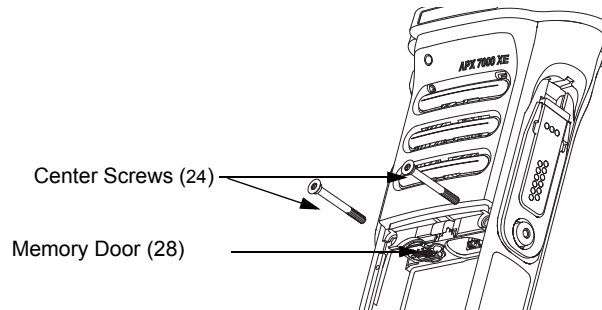

Figure 8-53. Insert Center Screws

3. If removed, insert the two bottom screws (25) into the screw holes at the bottom of the radio as shown in [Figure 8-54.](#), and torque to 10 in-lbs.

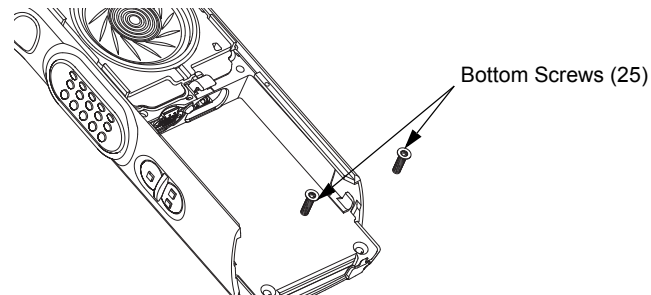

Figure 8-54. Insert Bottom Screws

**NOTE:** Refer to the appropriate section in this manual for reinstalling the antenna, battery, or any other accessory that was previously connected or attached to the radio prior to servicing.

## 8.10 Ensuring Radio Submergibility

This section discusses radio submergibility concerns, tests, and disassembly and reassembly of ASTRO APX 7000XE radios.

### 8.10.1 Standards

ASTRO APX 7000XE radio models meet the stringent requirements of U. S. MIL-STD-810C, Method 512.1, Procedure I; MIL-STD-810D, Method 512.2, Procedure I; MIL-STD-810E, Method 512.3, Procedure I; and MIL-STD-810F, Method 512.4, Procedure I, which require the radio to maintain watertight integrity when immersed in six (6) feet of water for two hours.

### 8.10.2 Servicing

APX 7000XE radios shipped from the Motorola Solutions factory have passed vacuum testing and should not be disassembled. If disassembly is necessary, refer to qualified service personnel and service shops capable of restoring the watertight integrity of the radio.



Caution

It is strongly recommended that maintenance of the radio be deferred to qualified service personnel and service shops. This is of paramount importance as irreparable damage to the radio can result from service by unauthorized persons. If disassembly is necessary, unauthorized attempts to repair the radio may void any existing warranties or extended performance agreements with Motorola. It is also recommended that submergibility be checked annually by qualified service personnel.

### 8.10.3 Water Exposure

If the radio is exposed to water, shake the radio to remove the excess water from the speaker grille and microphone ports areas before operating; otherwise, the sound may be distorted until the water has evaporated, or is dislodged from these areas.

### 8.10.4 Specialized Test Equipment

This section summarizes the specialized test equipment necessary for testing the integrity of ASTRO APX 7000XE radios.

To ensure that the radio is truly a watertight unit, special testing, test procedures, and specialized test equipment are required. The special testing involves a vacuum check of the radio and pressure testing (troubleshooting) for water leaks if the vacuum check fails. The specialized test equipment is needed to perform the vacuum check and pressure testing, if required.

#### 8.10.4.1 Vacuum Pump Kit NLN9839\_

The Vacuum Pump Kit includes a Vacuum Pump with gauge and a Vacuum Hose. The Vacuum Adapter (p/n 66009259001) which connects the vacuum pump to the radio, must be ordered separately.

#### 8.10.4.2 Pressure Pump Kit NTN4265\_

The Pressure Pump Kit includes a Pressure Pump with gauge and a Pressure Hose. As with the Vacuum Pump Kit above, the Vacuum Adapter connects the pressure pump to the radio.

### 8.10.5 Disassembly

Disassemble the radio according to [Section “8.7 Radio Disassembly” on page 2:8-12](#).

### 8.10.6 Reassembly

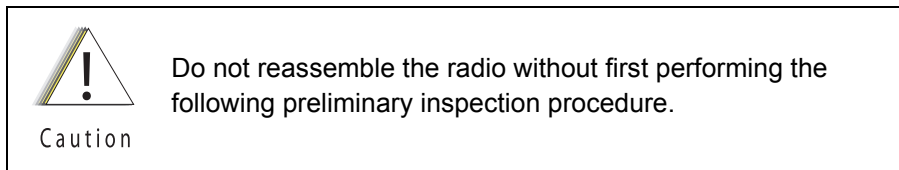

To reassemble the radio:

1. Inspect the seal on the Back Chassis Assembly (E, M) for any damage or foreign material.
2. Inspect the seal on the Speaker Module (B) for any damage or foreign material.
3. Inspect the Battery Connector Seal (35) on the RF Board Assembly (F) for any damage.
4. Inspect the mating seal surfaces on the Main Chassis (4) for all of the above seals for damage or foreign material that might prevent the seals from sealing properly.

Continue reassembling the radio according to [Section “8.9 Radio Reassembly” on page 2:8-29](#). Tighten all hardware that was loosened or removed.

### 8.10.7 Vacuum Test

The Vacuum Test uses a Vacuum Pump to create a negative pressure condition inside the radio. The gauge measures this pressure and is used to monitor any pressure changes in the radio. A properly sealed, watertight radio should have minimal change in pressure during the test.

Before starting the vacuum test:

- Remove the battery and antenna.
- Remove the Universal Connector Cover (38) or any other accessories to expose the universal connector.

**NOTE:** Refer to the exploded view diagrams and parts lists found in [“Chapter 10: Exploded Views and Parts Lists” on page 2:10-1](#).



### 8.10.7.1 Vacuum Tool Setup

1. Attach one end of the hose to the Vacuum Pump. Attach the other side of the hose to the Vacuum Adapter.
2. Tool Leak Test:
  - i. Block the open end of the Vacuum Adapter.
  - ii. Pull the knob on the Vacuum Pump to create vacuum.
  - iii. Pump at least 15 inHg.
  - iv. Watch the gauge for a minute. If there is any loss of vacuum, repair or replace the tool.
3. Ensure that the seal is attached to the Vacuum Adapter.

### 8.10.7.2 Attaching Grille Eliminator

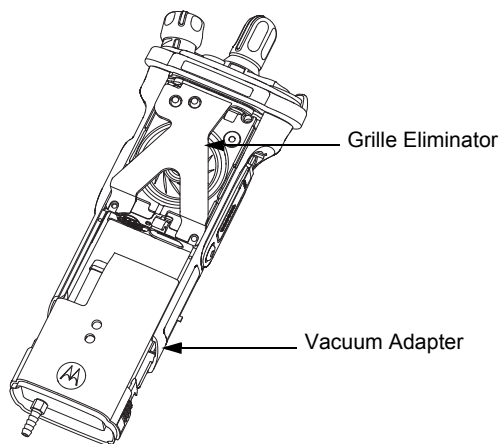

Figure 8-55. Attaching Grille Eliminator

1. Remove the Speaker Grille (22) by following steps in [Section 8.7.1 on page 2:8-12](#) and remove the Memory Door (28).
2. Slide the top of the Grille Eliminator under the Control Top Bezel (10) and swing it down towards the radio. Secure the Grille Eliminator using the two center screws (24) with a torque of 10 in lbs. See [Figure 8-55](#).

### 8.10.7.3 Test Procedure

1. Attach the Vacuum Adapter onto the radio in the same manner as a radio battery. Ensure both latches are clicked into place.
2. Place the radio on a flat surface with the Grille Eliminator facing upward.
3. Pull the knob on the Vacuum Pump to create vacuum. The vacuum test pressure should be between 5–7 inHg.



Caution

Ensure that the vacuum pressure NEVER exceeds 7 inHg. The radio has pressure sensitive components that can be damaged if the pressure exceeds this limit.

4. Observe the gauge for approximately 2 minutes.
  - If the needle falls less than 2 inHg, the radio passes the vacuum test.
    - i. Remove the Grille Eliminator
    - ii. Visually inspect the Port Seal Label (21) for proper adhesion to the Speaker Module (18). Make sure there are no wrinkles or cuts to the material that would cause a leak. Replace seal if damaged. (See appropriate section for servicing the seals).
    - iii. If the seal passes this inspection, this radio is approved for submergibility. No additional testing is required.
    - iv. Replace the Speaker Grille Assembly (22) and Memory Door (28) as described in the reassembly procedures.
  - If the needle falls more than 2 inHg, the radio fails the vacuum test and the radio might leak if submerged. Additional troubleshooting of the radio is required.
    - i. Keep the Grille Eliminator and Vacuum Adapter on but remove the Vacuum Pump from the Vacuum Adapter.
    - ii. Goto [Section "8.10.8 Pressure Test \(using NTN4265\\_\)"](#) on page 2:8-40.

### 8.10.8 Pressure Test (using NTN4265\_)

Pressure testing the radio is necessary only if the radio has failed the vacuum test. Do not perform the pressure test until the vacuum test has been completed. Pressure testing involves creating a positive pressure condition inside the radio, submerging the radio in water, and observing the radio for a stream of bubbles (leak). Since all areas of the radio are being checked, observe the entire unit carefully for the possibility of multiple leaks before completing this test.

**NOTES:**When Radio is placed under the water there will be some air trapped which will be released. This is not a failure.

Refer to the exploded view diagrams and parts lists found in ["Chapter 10: Exploded Views and Parts Lists"](#) on page 2:10-1.

The Grille Eliminator must be used to conduct the pressure test:  
If the radio is still set up from vacuum test, skip steps 1 through 4.

To conduct the pressure test:

1. Remove the Speaker Grille (22) by following the steps from [Section "8.7.1 Removal of the Speaker Grille Assemblies \(A\)"](#) on page 2:8-12 and remove the Memory Door (28).
2. Slide the top of the Grille Eliminator under the Control Top Bezel (10) and swing it down towards the radio. Secure the Grille Eliminator using the two center screws (24) with a torque of 10 in lbs. See [Figure 8-55](#).
3. Ensure that a seal is attached to the Vacuum Adapter.
4. Attach the Vacuum Adapter onto the radio in the same manner as a radio battery. Ensure both the latches are clicked into place.
5. Attach one end of the hose to the Pressure Pump. Attach the other side of the hose to the Vacuum Adapter.

6. Operate the pump until the gauge reads approximately 1 psig.



Caution

Pressure must remain between 0.5 psig and 1.5 psig. Pressure lower than 0.5 psig may allow water into the radio, which will damage the radio.



Caution

Ensure that the pressure NEVER exceeds 1.5 psig. The radio has pressure sensitive components that can be damaged if the pressure exceeds this limit.

7. Maintain the pressure around 1 psig and submerge the radio into a water-filled container.
8. Watch for any continuous series of bubbles. A steady stream of bubbles indicates a sign of leakage.

**NOTE:** Some accumulation of air may be entrapped in the main housing which may cause a false diagnosis of a leak. Ensure there is a steady stream of bubbles before concluding there is a leak.

9. Note all of the seal areas that show signs of leakage. Rotate the radio to view all sides to pinpoint the problem(s) to one (or more) of the following areas:
  - Seal Interfaces
  - Speaker Assembly
  - Battery Connector Seal
  - Main Chassis, including the Control Top
  - Back Chassis
10. Remove the radio from the water container and dry the radio thoroughly. Be especially careful to dry the area around the Memory Door (28).



Caution

To avoid equipment damage, keep the area around the memory card opening dry to prevent water from entering the radio.

11. With the Radio in an upright position and Control Top up, remove the vacuum adapter by squeezing the release latches, and pulling the adapter down and away from the radio.
12. Ensure the area around the Memory Door (28) opening is dry.
13. Dry the remainder of the radio and remove the Grille Eliminator.
14. See ["8.10.9: Troubleshooting Leak Areas"](#) on page 2:8-42.

## 8.10.9 Troubleshooting Leak Areas

Before repairing any leak, first read all of the steps within the applicable section. This will help to eliminate unnecessary disassembly and reassembly of a radio with multiple leaks. Troubleshoot only the faulty seal areas listed in “[8.10.8: Pressure Test \(using NTN4265\\_\)](#)” on page 2:8-40 and, when multiple leaks exist, in the order listed.

**NOTES:**All disassembly and reassembly methods can be found in [Section 8.7.](#) and [Section 8.9.](#)

If in the field, water is found around the battery leads, the O-ring on the Battery should be inspected and replaced if needed.

### 8.10.9.1 Seal Interfaces

- If leak occurs at one or more of the seal interfaces, disassembly of the component(s) and inspection of the interfaces to determine if there is any damage. If no damage is observed, re-assemble the radio as directed.
- If damage has occurred, replacement parts will be needed.

### 8.10.9.2 Speaker Module

- If leak occurs through the Microphone Membrane (19) or the Port Seal (20), replace these items.
- If leak occurs elsewhere on the Speaker Module (B), the module will need to be replaced.

### 8.10.9.3 Battery Contact Seal

- If leak occurs due to damage to the Battery Connector Seal (35), it will need to be replaced.

### 8.10.9.4 Back Chassis

- If leak occurs elsewhere on the Back Chassis (E/M), it will need to be replaced.

### 8.10.9.5 Control Top

- If leak occurs through the antenna or the Control Top Seal (14), replace it.
- If leak occurs elsewhere on the Control Top Assembly (J), it will need to be replaced.

### 8.10.9.6 Main Chassis

- If leak occurs on the Back Chassis (E/M), it will need to be replaced.

---

## Chapter 9 Basic Troubleshooting

This section of the manual contains troubleshooting charts and error codes that will help you to isolate a problem. Level one and two troubleshooting will support only radio alignment, programming, battery replacement, and knob replacement, and circuit board replacement.

Component-level service information can be found in the “ASTRO APX 7000/ APX 7000XE Portable Radios Detailed Service Manual,” Motorola publication number 6875961M01.

### 9.1 Power-Up Error Codes

When the radio is turned on (power-up), the radio performs self-tests to determine if its basic electronics and software are in working order. Problems detected during these tests are presented as error codes on the radio’s display. For non-display radios, the problem will be presented at power-up by a single, low-frequency tone. The radio should be sent to the depot if cycling power and reprogramming the code plug do not solve the problem. The presence of an error should prompt the user that a problem exists and that a service technician should be contacted.

Self-test errors are classified as either fatal or non-fatal. Fatal errors will inhibit user operation; non-fatal errors will not. Use [Table 9-1](#) to aid in understanding particular power-up error code displays.

*Table 9-1. Power-Up Error Code Displays*

Error Code	Description	Corrective Action
01/02	FLASH ROM Codeplug Checksum Non-Fatal Error	Reprogram the codeplug
01/12	Security Partition Checksum Non-Fatal Error	Send radio to depot
01/81	Host ROM Checksum Fatal Error	Send radio to depot
01/82	FLASH ROM Codeplug Checksum Fatal Error	Reprogram the codeplug
01/84	External EEPROM Blank (or SLIC failure) Fatal Error	Send radio to depot
01/88	External RAM Fatal Error – <b>Note:</b> Not a checksum failure	Send radio to depot
01/90	General Hardware Failure Fatal Error	Turn the radio off, then on
01/92	Security Partition Checksum Fatal Error	Send radio to depot
01/93	FLASHport Authentication Code Failure	Send radio to depot
01/94	Internal EEPROM Blank Fatal Error.	Send radio to depot
01/98	Internal RAM Fail Fatal Error	Send radio to depot
01/A0	ABACUS Tune Failure Fatal Error	Send radio to depot
01/A2	Tuning Codeplug Checksum Fatal Error	Send radio to depot
02/81	DSP ROM Checksum Fatal Error	Send radio to depot
02/88	DSP RAM Fatal Error – <b>Note:</b> Not a checksum failure	Turn the radio off, then on

Table 9-1. Power-Up Error Code Displays (Continued)

Error Code	Description	Corrective Action
02/90	General DSP Hardware Failure (DSP startup message not received correctly)	Turn the radio off, then on
09/10	Secure Hardware Error	Turn the radio off, then on
09/90	Secure Hardware Fatal Error	Turn the radio off, then on

**Note:** If the corrective action does not fix the failure, send the radio to the depot.

## 9.2 Operational Error Codes

During radio operation, the radio performs dynamic tests to determine if the radio is working properly. Problems detected during these tests are presented as error codes on the radio’s display. The presence of an error code should prompt a user that a problem exists and that a service technician should be contacted. Use Table 9-2 to aid in understanding particular operational error codes.

Table 9-2. Operational Error Code Displays

Error Code	Description	Corrective Action
FAIL 001	Synthesizer Out-of-Lock	1. Reprogram external codeplug 2. Send radio to depot
FAIL 002	Selected Mode/Zone Codeplug Checksum Error	Reprogram external codeplug

## 9.3 Receiver Troubleshooting

Table 9-3 lists the possible causes of, and corrections for, receiver problems.

Table 9-3. Receiver Troubleshooting Chart

Symptom	Possible Cause	Correction or Test (Measurements at Room Temperature)
Radio Dead; Display Does Not Turn On	1. Dead Battery	Replace with charged battery
	2. Blown Fuse	Send radio to depot
	3. On/Off Switch	
	4. Regulators	
Radio Dead; Display Turns On	1. VOCON Board	Send radio to depot
	2. RF Board	
	3. Expander Board	

Table 9-3. Receiver Troubleshooting Chart (Continued)

Symptom	Possible Cause	Correction or Test (Measurements at Room Temperature)
Radio On; Front Display Off	High operating temperature (above 80°C)	Allow radio to return to normal operating temperature.
No Receive Audio, or Receiver Does Not Unmute	Programming	1. Check if transmitted signal matches the receiver configuration (PL, DPL, etc.) 2. Check if radio able to unmute with monitor function enabled
Audio Distorted or Not Loud Enough	Synthesizer Not On Frequency	Check synthesizer frequency by measuring the transmitter frequency; realign if off by more than $\pm 1000$ Hz
RF Sensitivity Poor	1. Synthesizer Not On Frequency	Check synthesizer frequency by measuring the transmitter frequency; realign if off by more than $\pm 1000$ Hz
	2. Antenna Switch/Connector	Send radio to depot
	3. Receiver Front-End Tuning	Check RF front-end tuning for optimum sensitivity using the tuner
Radio Will Not Turn Off	VOCON Board	Send radio to depot

## 9.4 Transmitter Troubleshooting

Table 9-4 lists the possible causes of, and corrections for, transmitter problems.

Table 9-4. Transmitter Troubleshooting Chart

Symptom	Possible Cause	Correction or Test (Measurements Taken at Room Temperature)
No RF Power Out	1. TX Power Level or Frequency	Check TX power level and frequency programming (from tuner)
	2. No Injection To Power Amplifier	Send radio to depot
	3. Antenna Switch/Connector	
No Modulation; Distorted Modulation	1. Programming	Check deviation and compensation settings using the tuner
	2. VOCON Board	Send radio to depot
Bad Microphone Sensitivity	1. Check Deviation and Compensation	Realign if necessary
	2. Microphone	Send radio to depot

Table 9-4. Transmitter Troubleshooting Chart (Continued)

Symptom	Possible Cause	Correction or Test (Measurements Taken at Room Temperature)
No/Low signaling (PL, DPL, MDC)	1. Programming	Check programming
	2. VOCON Board	Send radio to depot
Cannot Set Deviation Balance	RF Board	Send radio to depot

## 9.5 Encryption Troubleshooting

Table 9-5 lists the possible causes of, and corrections for, encryption problems.

Table 9-5. Encryption Troubleshooting Chart

Symptom	Possible Cause	Corrective Action
No "KEYLOAD" on Radio Display When Keyloading Cable is Attached to the Radio Side Connector	1. Defective Keyload Cable	Send radio to depot
	2. Defective Radio	
Keyloader Displays "FAIL"	1. Wrong Keyloader Type	Use correct keyloader type. Refer to Keyloader User Guide for more information
	2. Bad Keyloader	Try another keyloader
	3. Defective Radio	Send radio to depot

## 9.6 Bluetooth Option / Expansion Board Troubleshooting

Table 9-6 lists the possible causes of, and corrections for, Bluetooth Option / Expansion Board problems.

Table 9-6. Bluetooth Option/Expansion Board Troubleshooting Chart

Message Displayed	Possible Cause	Corrective Action
Hardware board absent	Bluetooth Option / Expansion Board is not present on the radio and feature is enabled by a code plug.	Send radio to depot
Hardware board mismatch	When an option / expansion board feature is enabled in code plug, but the board (EB or OB) does not have corresponding capability.	Send radio to depot
Hardware board failed	Displayed if the board Deenumerated, Enumeration timed out, Option board device initialized with a Fatal Error.	Reset the radio. If this persists, send radio to the depot



Table 9-6. Bluetooth Option/Expansion Board Troubleshooting Chart (Continued)

Message Displayed	Possible Cause	Corrective Action
Update failed Please reset	Bluetooth Option / Expansion board firmware update fails.	Reset radio. if this persists, send radio to the depot

## 9.7 Bluetooth Troubleshooting

Table 9-7 lists the possible causes of, and corrections for, bluetooth problems.

Table 9-7. Bluetooth Troubleshooting Chart

Message Displayed	Possible Cause	Corrective Action
Non_Audio dev connect failed / Audio device connect failed	Displayed when the accessory fails to connect after pairing.	Clear all pairing information and try to pair and connect.
Bluetooth pairing failed	Accessory and Radio failed to pair through MPP/ NFC.	Retry pairing accessory with Radio.
Clear all BT devices failed	Radio was unable to clear information of all the accessories that are paired and/or connected.	Reset the radio.
Bluetooth on failed	Option Board is in an unknown state and is unable to process the request for Bluetooth ON.	Reset the radio. If this continues, send radio to the depot.

## Notes

## Chapter 10 Exploded Views and Parts Lists

This chapter contains exploded views and associated parts lists for the ASTRO APX 7000XE digital portable radios. The following table lists the exploded views for the APX 7000XE radio in different configurations:

*Table 10-1. APX 7000XE Exploded Views*

<b>View</b>	<b>Page</b>
<a href="#">APX 7000XE Top Display Exploded View</a>	<a href="#">2:10-2</a>
<a href="#">APX 7000XE Dual Display Exploded View</a>	<a href="#">2:10-4</a>

### 10.1 APX 7000XE Top Display Exploded View

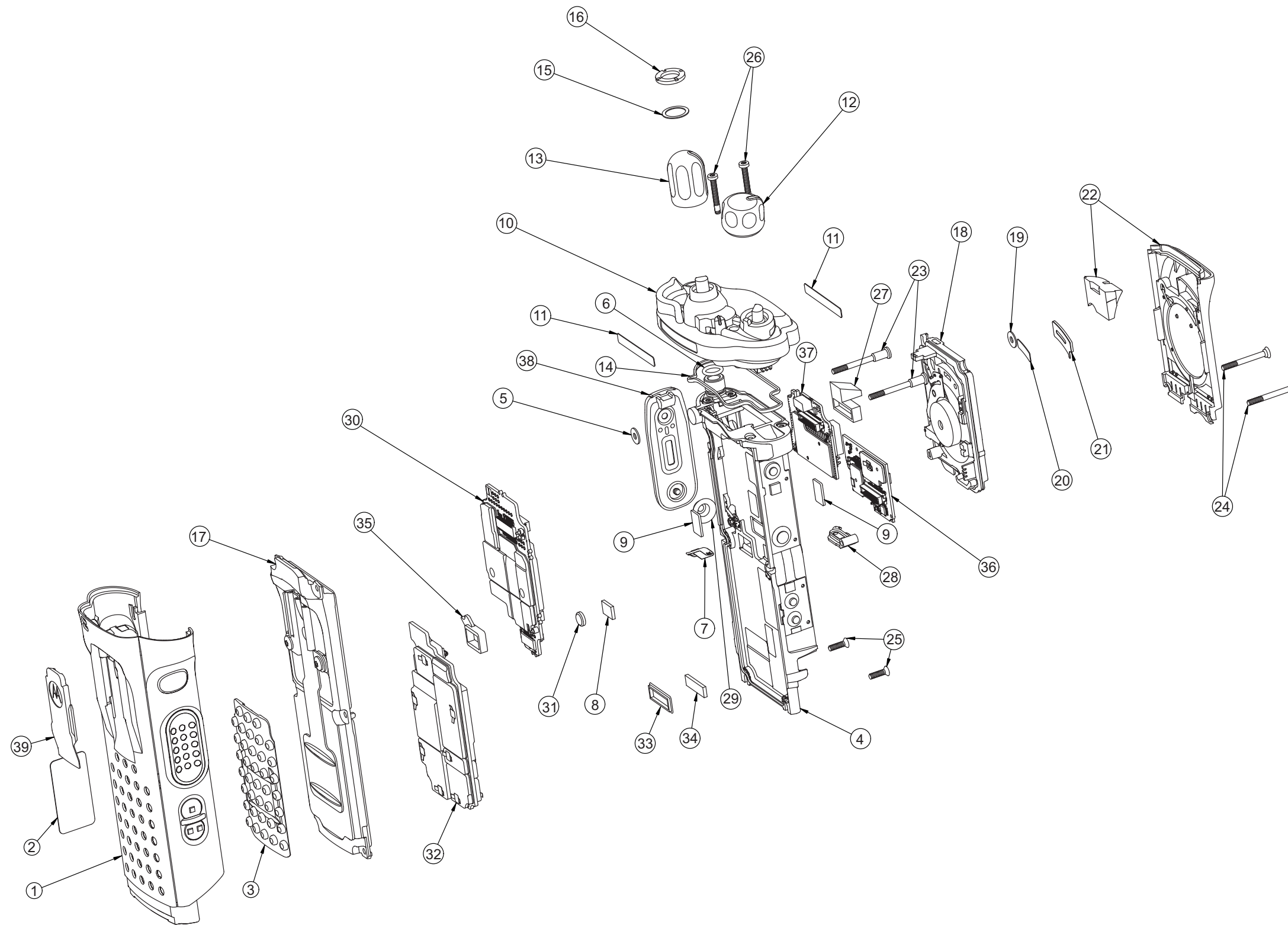

Figure 10-1. APX 7000XE Top Display Exploded View

## 10.2 APX 7000XE Top Display Exploded View Parts List

Item No.	Motorola Part Number	Description
1	15009584001 15009584003 <sup>1</sup> 15009584002 <sup>1</sup>	Housing, Assembly Black Housing, Assembly Impact Green Housing, Assembly Safety Yellow
2	3385836D09 3385836D08	Label, Blank, Top Display Label, FM, Top Display (where applicable)
3	38009295002	Grip, Rubber, Insert
4	01009304020	Assy, Main, Chassis
5	3275002C02	Seal, Membrane, Microphone
6	3275033C01	O-ring, Antenna Main
7	39711892H01	Contact, Chassis Ground
8	7505316J16	Pad, Coin Cell Battery
9	7575218H01	Pad (x2), Thermal, Exp & VOCON Board
10	01009506007 01009506008 01009506009	Control Top, Black Control Top, Safety Yellow Control Top, Impact Green
11	33009276001	Label, Control Top (x2)
12	36009258001	Knob, Volume
13	36009257001	Knob, Frequency
14	3275377H01	Seal, Control Top
15	0400129054	Washer, Lock Antenna
16	0275891B01	Nut, Spanner, Antenna
17	NHN7004_2	Sub-Assembly, Back Chassis, Top Display
18	NHN7002_	Module, Speaker
19	3275002C02	Seal, Membrane, Microphone
20	3271819H01	Seal, Port
21	5475160H01	Label, Seal, Port

Item No.	Motorola Part Number	Description
22	NHN7051_ NHN7052_ NHN7053_	Grille, Speaker Kit, Impact Green Grille, Speaker Kit, Safety Yellow Grille, Speaker Kit, Black
23	0375962B01	Screw (x2) M2.5 x 0.45, 30.10 LG
24	0375962B02	Screw (x2) M2.5 x 0.45, 24.45 LG
25	0375962B03	Screw (x2) M2.5 x 0.45, 9.2 LG
26	03009357001	Screw, Control Top (M2.5 x 0.45 x 18 )
27	32009064001	Plug, Support, Connector
28	3275882B01	Door, Seal, Memory
29	3875126H01	Cap, Chassis Boss, Universal Connector
30	MNCN6203_2	Assy, VOCON Board, Top Display
31	6003710K08	Battery, Backup, Coincell
32	MNUR4001_ MNUS4000_ MNUT4000_ MNUS4002_ MNUT4004_ MNUE7367_	Assembly, RF Board (7-800/VHF) Assembly, RF Board (7-800/UHF1) Assembly, RF Board (UHF1/VHF) Assembly, RF Board (7-800/UHF2) Assembly, RF Board (UHF2/VHF) Assembly, RF Board (UHF1/UHF2)
33	3275623B02	Pad, Thermal, Outer
34	75009299001	Pad, Thermal, Inner
35	3271829H01	Seal, Connector, Battery
36	MHLN6977_ MHLN7035_4	Assy, Board, Expansion
37 <sup>3</sup>	NNTN8160_	Bluetooth Upgrade Kit (where applicable)
38	1575250H01	Cover, Connector, Universal Connector
39	1575356H01	Cover, Clip, Belt (See <a href="#">Appendix A"Accessories" on page 3:A-1</a> )

**NOTE:**

1. HIGH IMPACT GREEN and PUBLIC SAFETY YELLOW Colored Housings can be serviced in the depot and can be ordered via AAD.
2. See [Table 10-2."Compatibility Table" on page 2:10-6](#)
3. Radios installed with the Option Board Kit NNTN8160\_ do not have the connector plug (32009064001).
4. With TI Chipset.

### 10.3 APX 7000XE Dual Display Exploded View

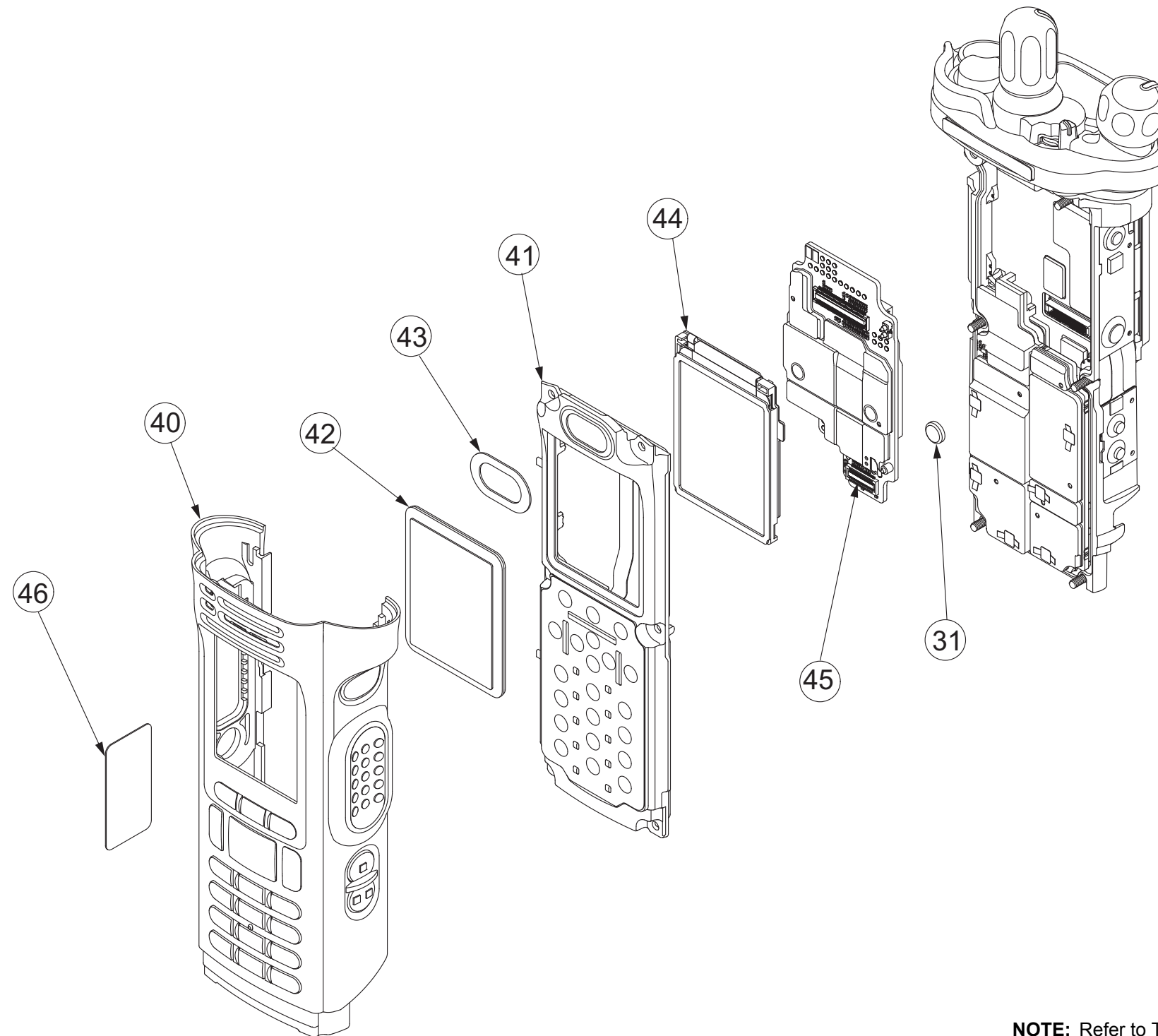

**NOTE:** Refer to Top Display view for items not exploded. Parts shown here are exclusive to Dual Display version.

Figure 10-2. APX 7000XE Dual Display Exploded View

## 10.4 APX 7000XE Dual Display Exploded View Parts List

Item No.	Motorola Part Number	Description
40	01009506013 01009506014 01009506015	Assy, Front Housing, Dual Display (Black) Assy, Front Housing, Dual Display (Yellow) Assy, Front Housing, Dual Display (Green)
41	NHN7017_2	Assy, Back Chassis, Dual Display
42	6175619B02	Lens, Color Display
43	3271816H01	Seal, Speaker, Dataside
44	01009304024 <sup>2</sup>	Display, Color, Back
45	MNCN6202_2	Assy, VOCON Board Dual Display
31	6003710K08	Battery, Backup, Coincell
46	3385836D11	Label, Main Housing FM, Dual Display (where applicable)

Table 10-2. Compatibility Table

<b>Compatibility Table</b>	Display, Color Back – 01009304024	Display, Color Back – 01009304019	Display, Color Back – 01009304003	Assy, Back Chassis – Top Display, NHN7004_	Assy, Back Chassis – Dual Display, NHN7017_	VOCON Board, MNCN6203_	VOCON Board, MNCN6202_	VOCON Board, MNCN6201_	VOCON Board, MNCN6200_
Display, Color Back – 01009304024	–	–	–	x	●	x	●	x	x
Display, Color Back – 01009304019	–	–	–	x	●	x	●	x	x
Display, Color Back – 01009304003	–	–	–	x	●	x	●	x	x
Assy, Back Chassis – Top Display, NHN7004_	x	x	x	–	–	●	x	●	x
Assy, Back Chassis – Dual Display, NHN7017_	●	●	●	–	–	x	●	x	x
VOCON Board, MNCN6203_	x	x	x	●	x	–	–	–	–
VOCON Board, MNCN6202_	●	●	●	x	●	–	–	–	–
VOCON Board, MNCN6201_	x	x	x	x	x	–	–	–	–
VOCON Board, MNCN6200_	x	x	x	x	x	–	–	–	–
<b>Note:</b> ● Compatible x Not Compatible – Not Applicable									



---

# Index

## Numerics

- 700–800 MHz
  - radio specifications 2:ivii
- 700–800 MHz and UHF1
  - model chart 2:ii
- 700–800 MHz and UHF2
  - model chart 2:iiv
- 700–800 MHz and VHF
  - model chart 2:i

## A

- alignment, tuner
  - bit error rate test 2:6-24
  - introduction 2:6-1
  - main menu 2:6-2
  - radio information screen 2:6-4
  - reference oscillator 2:6-4
  - softpot use 2:6-2
  - test setup 2:6-1
  - transmit deviation balance 2:6-17
  - transmitter test pattern 2:6-26
- analog mode
  - receiving 2:3-2
  - transmitting 2:3-7
- antenna
  - attaching 2:8-6
  - removing 2:8-6
- antenna o-ring
  - servicing 2:8-20
- ARM theory of operation 2:3-12
- assemble
  - back chassis assembly 2:8-32
  - bluetooth option board assembly 2:8-34
  - expansion board assembly 2:8-33
  - frequency and volume knobs assembly 2:8-29
  - main housing assembly 2:8-32
  - RF board assembly 2:8-31
  - speaker grill assembly 2:8-36
  - top control assembly 2:8-29
  - vocon board assembly 2:8-30
- ASTRO mode
  - receiving 2:3-11
  - transmitting 2:3-11
- audio theory of operation 2:3-13

## B

- back chassis assembly
  - assemble 2:8-32
  - removing 2:8-16
  - top display
    - servicing 2:8-25, 2:8-27
- battery
  - attaching 2:8-7
  - removing 2:8-9
- bit error rate test 2:6-24
- bluetooth

- troubleshooting chart 2:9-5
- bluetooth option board assembly
  - assemble 2:8-34
- bluetooth option/expansion board
  - troubleshooting chart 2:9-4

## C

- chassis ground contact
  - servicing 2:8-21
- chassis pads
  - servicing 2:8-20
- chassis screw boss cap
  - servicing 2:8-20
- cleaning external plastic surfaces 2:2-1
- color display
  - servicing 2:8-25
- control top and keypad test mode, dual-display
  - version 2:5-6
- control top assembly
  - removing 2:8-19
  - servicing 2:8-22
- control top test mode
  - top-display version 2:5-8
- controller
  - ARM theory of operation 2:3-12
  - audio theory of operation 2:3-13
  - theory of operation 2:3-12
  - user interface block theory of operation 2:3-13
- controller expansion bay & option slot theory of operation 2:3-13

## D

- disassembly/reassembly
  - antenna
    - attaching 2:8-6
    - removing 2:8-6
  - back chassis assembly
    - removing 2:8-16
  - battery
    - attaching 2:8-7
    - removing 2:8-9
  - control top assembly
    - removing 2:8-19
  - expansion board assembly
    - removing 2:8-14
  - housing assembly
    - reassembling 2:8-29
  - introduction 2:8-1
  - knobs and top bezel assembly
    - removing 2:8-18
  - main chassis assembly
    - removing 2:8-20
  - main housing assembly
    - removing 2:8-15
  - RF board assembly
    - removing 2:8-17
  - speaker grill assembly
    - removing 2:8-12
  - speaker module
    - removing 2:8-13
  - universal connector cover

- attaching 2:8-11
- removing 2:8-10
- vocon board assembly
  - removing 2:8-18
- display radio
  - test mode
    - test environments 2:5-5
    - test frequencies 2:5-5
- dual-display version
  - control top and keypad test mode 2:5-6
  - entering test mode 2:5-3
  - RF test mode 2:5-5

**E**

- encryption
  - index
    - selecting with keypad 2:7-3
    - selecting with menu 2:7-3
  - key
    - erasing
      - all keys 2:7-4
      - key zeroization 2:7-3
    - selecting with keypad 2:7-2
    - selecting with menu 2:7-2
  - troubleshooting chart 2:9-4
- error codes
  - operational 2:9-2
  - power-up 2:9-1
- expansion bay & option slot theory of operation 2:3-13
- expansion board assembly
  - assemble 2:8-33
  - removing 2:8-14
  - servicing 2:8-24
- exploded view
  - complete
    - dual display version 2:10-4
    - top display version 2:10-2
  - partial
    - dual display 2:8-3
    - top display 2:8-2

**F**

- field programming equipment 2:4-3
- FLASHport 2:1-2
- frequency and volume knobs assembly
  - assemble 2:8-29

**H**

- handling precautions
  - non-ruggedized radios 2:2-1
  - XE radios 2:2-2
- housing assembly
  - reassembling 2:8-29

**I**

- index, encryption
  - selecting with keypad 2:7-3
  - selecting with menu 2:7-3

**K**

- key, encryption
  - erasing
    - all keys 2:7-4
    - key zeroization 2:7-3
  - loading 2:7-1
  - selecting with keypad 2:7-2
  - selecting with menu 2:7-2
- knobs and top bezel assembly
  - removing 2:8-18
  - servicing 2:8-22

**L**

- loading an encryption key 2:7-1

**M**

- main chassis assembly
  - removing 2:8-20
- main housing assembly
  - assemble 2:8-32
  - removing 2:8-15
- main lens
  - servicing 2:8-26
- maintenance
  - cleaning 2:2-1
  - inspection 2:2-1
  - ruggedized radio submergibility checks 2:2-1
- manual
  - notations 2:1-1
- microphone membrane
  - servicing 2:8-21, 2:8-28
- model chart
  - 700–800 MHz and UHF1 2:ii
  - 700–800 MHz and UHF2 2:iiv
  - 700–800 MHz and VHF 2:i
  - numbering system 2:ix
  - UHF1 and UHF2 2:iii
  - UHF1 and VHF 2:iii
  - UHF2 and VHF 2:iv
- model numbering system, radio 2:ix
- multikey
  - conventional 2:7-1
  - trunked 2:7-1

**N**

- notations
  - manual 2:1-1
  - warning, caution, and danger 2:1-1

**P**

- performance checks
  - receiver 2:5-9
  - test setup 2:5-1
  - transmitter 2:5-10
- performance test
  - tuner 2:6-24
- port seal label

- servicing 2:8-28
- power-up error codes 2:9-1
- precautions, handling 2:2-1

## R

- radio
  - alignment 2:6-1
  - basic description 2:1-2
  - dual-display model
    - RF test mode 2:5-5
  - dual-display version
    - control top and keypad test mode 2:5-6
    - entering display test mode 2:5-3
  - exploded view
    - complete dual display version 2:10-4
    - complete top display version 2:10-2
    - partial
      - dual display 2:8-3
      - top display 2:8-2
  - features 2:1-2
  - FLASHport feature 2:1-2
  - information screen 2:6-4
  - model numbering system 2:ix
  - models 2:1-2
  - reassembling
    - housing assembly 2:8-29
  - submergible models
    - disassembling 2:8-38
    - reassembling 2:8-38
  - submersibility
    - specialized test equipment 2:8-38
    - standards 2:8-37
    - vacuum test 2:8-38
  - test environments 2:5-5
  - test frequencies 2:5-5
  - test mode
    - dual-display version 2:5-3
    - top-display model 2:5-7
  - top-display version
    - control top test mode 2:5-8
    - entering test mode 2:5-7
    - RF test mode 2:5-7
- receiver
  - ASTRO conventional channel tests 2:5-9
  - performance checks 2:5-9
  - troubleshooting 2:9-2
- receiving
  - analog mode 2:3-2
  - ASTRO mode 2:3-11
- reference oscillator alignment 2:6-4
- RF board assembly
  - assemble 2:8-31
  - removing 2:8-17
  - servicing 2:8-23
- RF test mode
  - dual-display version 2:5-5
  - top-display version 2:5-7
- ruggedized radios
  - submergibility checks 2:2-1

## S

- service aids 2:4-2
- servicing
  - antenna o-ring 2:8-20
  - back chassis assembly
    - top display 2:8-25, 2:8-27
  - chassis ground contact 2:8-21
  - chassis pads 2:8-20
  - chassis screw boss cap 2:8-20
  - color display 2:8-25
  - control top assembly 2:8-22
  - expansion board assembly 2:8-24
  - knobs and top bezel assembly 2:8-22
  - main lens 2:8-26
  - microphone membrane 2:8-21, 2:8-28
  - port seal label 2:8-28
  - RF board assembly 2:8-23
  - speaker module 2:8-28
  - speaker seal 2:8-26
  - vocon board assembly 2:8-23
- softpot 2:6-2
- speaker grill assembly
  - assemble 2:8-36
  - removing 2:8-12
- speaker module
  - removing 2:8-13
  - servicing 2:8-28
- speaker seal
  - servicing 2:8-26
- specifications
  - 700–800 MHz radios 2:ivii
  - UHF1 radios 2:iviii
  - UHF2 radios 2:ix
  - VHF radios 2:ivi
- standards, radio submersibility 2:8-37
- submergibility
  - radio disassembly 2:8-38
  - radio reassembly 2:8-38
- submersibility
  - specialized test equipment 2:8-38
  - standards 2:8-37
  - vacuum test 2:8-38

## T

- test equipment
  - recommended 2:4-1
  - specialized submersibility 2:8-38
- test mode, entering
  - dual-display version 2:5-3
  - top-display version 2:5-7
- test setup
  - alignment 2:6-1
  - performance checks 2:5-1
- tests
  - receiver
    - ASTRO conventional channels 2:5-9
    - performance checks 2:5-9
  - transmitter
    - ASTRO conventional channels 2:5-11
    - performance checks 2:5-10
- theory of operation
  - analog mode 2:3-2

- ASTRO mode 2:3-11
- controller 2:3-12
  - ARM 2:3-12
  - audio 2:3-13
  - expansion bay & option slot 2:3-13
  - user interface block 2:3-13
- major assemblies 2:3-1
- overview 2:3-1
- top control assembly
  - assemble 2:8-29
- top-display version
  - control top test mode 2:5-8
  - entering test mode 2:5-7
  - RF test mode 2:5-7
- transmit deviation
  - balance alignment 2:6-17
- transmitter
  - ASTRO conventional channel tests 2:5-11
  - performance checks 2:5-10
  - test pattern 2:6-26
  - troubleshooting 2:9-3
- transmitting
  - analog mode 2:3-7
  - ASTRO mode 2:3-11
- troubleshooting
  - bluetooth option/expansion board problems 2:9-4
  - bluetooth problems 2:9-5
  - encryption problems 2:9-4
  - introduction 2:9-1
  - operational error codes 2:9-2
  - power-up error codes 2:9-1
  - receiver problem chart 2:9-2
  - transmitter problem chart 2:9-3
- tuner
  - bit error rate test 2:6-24
  - introduction 2:6-1
  - main menu 2:6-2
  - performance test 2:6-24
  - radio information screen 2:6-4
  - reference oscillator alignment 2:6-4
  - test setup 2:6-1
  - transmit deviation balance alignment 2:6-17
  - transmitter alignment 2:6-4
  - transmitter test pattern 2:6-26

**U**

- UHF Specifications 2:ivii
- UHF1
  - radio specifications 2:iviii
- UHF1 and UHF2
  - model chart 2:iii
- UHF1 and VHF
  - model chart 2:iii
- UHF2
  - radio specifications 2:ix
- UHF2 and VHF
  - model chart 2:iv
- universal connector cover
  - attaching 2:8-11
  - removing 2:8-10
- user interface block theory of operation 2:3-13

**V**

- vacuum test, submersibility 2:8-38
- view, exploded
  - complete dual display version 2:10-4
  - complete top display version 2:10-2
  - partial
    - dual display 2:8-3
    - top display 2:8-2
- vocon board assembly
  - assemble 2:8-30
  - removing 2:8-18
  - servicing 2:8-23

**W**

- warning, caution, and danger notations 2:1-1

**X**

- XE radios
  - handling precautions 2:2-2

---

**ASTRO APX 7000/ APX 7000XE**  
**Digital Portable Radios**

Section 3  
Appendices

---

---

## Notes

---

## Appendix A Accessories

Motorola Solutions provides the following approved optional accessories to improve the productivity of the APX 7000/ APX 7000XE portable radio.

**For a complete list of Motorola-approved antennas, batteries, and other accessories, visit the following web site:**

**<http://www.motorolasolutions.com/APX>**

## Notes



---

## **Appendix B Replacement Parts Ordering**

### **B.1 Basic Ordering Information**

When ordering replacement parts or equipment information, the complete identification number should be included. This applies to all components, kits, and chassis. If the component part number is not known, the order should include the number of the chassis or kit of which it is a part, and sufficient description of the desired component to identify it.

### **B.2 Transceiver Board, VOCON Board and Expander Board Ordering Information**

When ordering a replacement Transceiver Board, VOCON Board or Expander Board, refer to the applicable Model Chart in the front of this manual. Read the Transceiver Board, VOCON Board, or Expander Board note, and include the proper information with your order.

### **B.3 Motorola Online**

Motorola Online users can access our online catalog at

<http://www.motorola.com/businessonline>

To register for online access, please call 1-800-422-4210 (for U.S. and Canada Service Centers only). International customers can obtain assistance at <http://www.motorola.com/businessonline>

### **B.4 Mail Orders**

Mail orders are only accepted by the US Federal Government Markets Division (USFGMD).

Motorola  
7031 Columbia Gateway Drive  
3rd Floor – Order Processing  
Columbia, MD 21046  
U.S.A.

## **B.5 Telephone Orders**

Radio Products and Solutions Organization\*  
(United States and Canada)  
7:00 AM to 7:00 PM (Central Standard Time)  
Monday through Friday (Chicago, U.S.A.)  
1-800-422-4210  
1-847-538-8023 (United States and Canada)

U.S. Federal Government Markets Division (USFGMD)  
1-877-873-4668  
8:30 AM to 5:00 PM (Eastern Standard Time)

## **B.6 Fax Orders**

Radio Products and Solutions Organization\*  
(United States and Canada)  
1-800-622-6210  
1-847-576-3023 (United States and Canada)

USFGMD  
(Federal Government Orders)  
1-800-526-8641 (For Parts and Equipment Purchase Orders)

## **B.7 Parts Identification**

Radio Products and Solutions Organization\*  
(United States and Canada)  
1-800-422-4210

## **B.8 Product Customer Service**

Radio Products and Solutions Organization (United States and Canada)  
1-800-927-2744

\* The Radio Products and Solutions Organization (RPSO) was formerly known as the Radio Products Services Division (RPSD) and/or the Accessories and Aftermarket Division (AAD).

---

# Glossary

This glossary contains an alphabetical listing of terms and their definitions that are applicable to ASTRO portable and mobile subscriber radio products.

Term	Definition
<b>A/D</b>	<i>See analog-to-digital conversion.</i>
<b>Abacus IC</b>	A custom integrated circuit providing a digital receiver intermediate frequency (IF) backend.
<b>active channel</b>	A channel that has traffic on it.
<b>ACK</b>	Acknowledgment of communication.
<b>ADC</b>	<i>See analog-to-digital converter.</i>
<b>ADDAG</b>	<i>See Analog-to-Digital, Digital-to-Analog and Glue.</i>
<b>analog</b>	Refers to a continuously variable signal or a circuit or device designed to handle such signals. <i>See also digital.</i>
<b>Analog-to-Digital, Digital-to-Analog and Glue</b>	An integrated circuit designed to be an interface between the radio's DSP, which is digital, and the analog transmitter and receiver ICs.
<b>analog-to-digital conversion</b>	Conversion of an instantaneous dc voltage level to a corresponding digital value. <i>See also D/A.</i>
<b>analog-to-digital converter</b>	A device that converts analog signals into digital data. <i>See also DAC.</i>
<b>ASTRO 25 trunking</b>	Motorola standard for wireless digital trunked communications.
<b>ASTRO conventional</b>	Motorola standard for wireless analog or digital conventional communications.
<b>automatic level control</b>	A circuit in the transmit RF path that controls RF power amplifier output, provides leveling over frequency and voltage, and protects against high VSWR.
<b>autoscan</b>	A feature that allows the radio to automatically scan the members of a scan list.
<b>band</b>	Frequencies allowed for a specific purpose.
<b>BGA</b>	<i>See ball grid array.</i>
<b>ball grid array</b>	A type of IC package characterized by solder balls arranged in a grid that are located on the underside of the package.
<b>Call Alert</b>	Privately paging an individual by sending an audible tone.

Term	Definition
<b>carrier squelch</b>	Feature that responds to the presence of an RF carrier by opening or unmuting (turning on) a receiver's audio circuit. A squelch circuit silences the radio when no signal is being received so that the user does not have to listen to "noise."
<b>central controller</b>	A software-controlled, computer-driven device that receives and generates data for the trunked radios assigned to it. It monitors and directs the operations of the trunked repeaters.
<b>channel</b>	A group of characteristics, such as transmit/receive frequency pairs, radio parameters, and encryption encoding.
<b>CODEC</b>	<i>See coder/decoder.</i>
<b>coded squelch</b>	Used on conventional channels to ensure that the receiver hears only those communications intended for the receiver.
<b>codeplug</b>	Firmware that contains the unique personality for a system or device. A codeplug is programmable and allows changes to system and unit parameters. <i>See also firmware.</i>
<b>coder/decoder</b>	A device that encodes or decodes a signal.
<b>control channel</b>	In a trunking system, one of the channels that is used to provide a continuous, two-way/data-communications path between the central controller and all radios on the system.
<b>conventional</b>	Typically refers to radio-to-radio communications, sometimes through a repeater. Frequencies are shared with other users without the aid of a central controller to assign communications channels. <i>See also trunking.</i>
<b>conventional scan list</b>	A scan list that includes only conventional channels.
<b>CPS</b>	<i>See Customer Programming Software.</i>
<b>cursor</b>	A visual tracking marker (a blinking line) that indicates a location on a display.
<b>Customer Programming Software</b>	Software with a graphical user interface containing the feature set of an ASTRO radio. <i>See also RSS.</i>
<b>D/A</b>	<i>See digital-to-analog conversion.</i>
<b>DAC</b>	<i>See digital-to-analog converter.</i>
<b>deadlock</b>	Displayed by the radio after three failed attempts to unlock the radio. The radio must be powered off and on prior to another attempt.
<b>default</b>	A pre-defined set of parameters.

Term	Definition
<b>digital</b>	Refers to data that is stored or transmitted as a sequence of discrete symbols from a finite set; most commonly this means binary data represented using electronic or electromagnetic signals. <i>See also analog.</i>
<b>digital-to-analog conversion</b>	Conversion of a digital signal to a voltage that is proportional to the input value. <i>See also A/D.</i>
<b>digital-to-analog converter</b>	A device that converts digital data into analog signals. <i>See also ADC.</i>
<b>Digital Private Line</b>	A type of digital communications that utilizes privacy call, as well as memory channel and busy channel lock out to enhance communication efficiency.
<b>digital signal processor</b>	A microcontroller specifically designed for performing the mathematics involved in manipulating analog information, such as sound, that has been converted into a digital form. DSP also implies the use of a data compression technique.
<b>digital signal processor code</b>	Object code executed by the Digital Signal Processor in an ASTRO subscriber radio. The DSP is responsible for computation-intensive tasks, such as decoding ASTRO signaling.
<b>dispatcher</b>	An individual who has radio-system management duties and responsibilities.
<b>DPL</b>	<i>See Digital Private Line. See also PL.</i>
<b>DSP</b>	<i>See digital signal processor.</i>
<b>DSP code</b>	<i>See digital signal processor code.</i>
<b>dynamic regrouping</b>	A feature that allows the dispatcher to temporarily reassign selected radios to a single special channel so they can communicate with each other.
<b>EEPOT</b>	Electrically Programmable Digital Potentiometer.
<b>EEPROM</b>	<i>See Electrically Erasable Programmable Read-Only Memory.</i>
<b>Electrically Erasable Programmable Read-Only Memory</b>	A special type of PROM that can be erased by exposing it to an electrical charge. An EEPROM retains its contents even when the power is turned off.
<b>Failsoft</b>	A backup system that allows communication in a non-trunked, conventional mode if the trunked system fails.
<b>FCC</b>	Federal Communications Commission.

Term	Definition
<b>firmware</b>	Code executed by an embedded processor such as the Host or DSP in a subscriber radio. This type of code is typically resident in non-volatile memory and as such is more difficult to change than code executed from RAM.
<b>FGU</b>	<i>See frequency generation unit.</i>
<b>flash</b>	A non-volatile memory device similar to an EEPROM. Flash memory can be erased and reprogrammed in blocks instead of one byte at a time.
<b>FLASHcode</b>	A 13-digit code which uniquely identifies the System Software Package and Software Revenue Options that are enabled in a particular subscriber radio. FLASHcodes are only applicable for radios which are upgradeable through the FLASHport process.
<b>FLASHport</b>	A Motorola term that describes the ability of a radio to change memory. Every FLASHport radio contains a FLASHport EEPROM memory chip that can be software written and rewritten to, again and again.
<b>FMR</b>	<i>See Florida Manual Revision.</i>
<b>Florida Manual Revision</b>	A publication that provides supplemental information for its parent publication before it is revised and reissued.
<b>frequency</b>	Number of times a complete electromagnetic-wave cycle occurs in a fixed unit of time (usually one second).
<b>frequency generation unit</b>	This unit generates ultra-stable, low-phase noise master clock and other derived synchronization clocks that are distributed throughout the communication network.
<b>General-Purpose Input/Output</b>	Pins whose function is programmable.
<b>GPIO</b>	<i>See General-Purpose Input/Output.</i>
<b>hang up</b>	Disconnect.
<b>home display</b>	The first information display shown after a radio completes its self test.
<b>host code</b>	Object code executed by the host processor in an ASTRO subscriber radio. The host is responsible for control-oriented tasks such as decoding and responding to user inputs.
<b>IC</b>	<i>See integrated circuit.</i>
<b>IF</b>	Intermediate Frequency.
<b>IMBE</b>	A sub-band, voice-encoding algorithm used in ASTRO digital voice.
<b>inbound signaling word</b>	Data transmitted on the control channel from a subscriber unit to the central control unit.

Term	Definition
<b>integrated circuit</b>	An assembly of interconnected components on a small semiconductor chip, usually made of silicon. One chip can contain millions of microscopic components and perform many functions.
<b>ISW</b>	<i>See inbound signaling word.</i>
<b>key-variable loader</b>	A device used to load encryption keys into a radio.
<b>kHz</b>	<i>See kilohertz.</i>
<b>kilohertz</b>	One thousand cycles per second. Used especially as a radio-frequency unit.
<b>KVL</b>	<i>See key-variable loader.</i>
<b>LCD</b>	<i>See liquid-crystal display.</i>
<b>LED</b>	<i>See LED.</i>
<b>light emitting diode</b>	An electronic device that lights up when electricity is passed through it.
<b>liquid-crystal display</b>	An LCD uses two sheets of polarizing material with a liquid-crystal solution between them. An electric current passed through the liquid causes the crystals to align so that light cannot pass through them.
<b>LO</b>	Local oscillator.
<b>low-speed handshake</b>	150-baud digital data sent to the radio during trunked operation while receiving audio.
<b>LSH</b>	<i>See low-speed handshake.</i>
<b>Master In Slave Out</b>	SPI data line from a peripheral to the MCU.
<b>Master Out Slave In</b>	SPI data line from the MCU to a peripheral.
<b>MCU</b>	<i>See microcontroller unit.</i>
<b>MDC</b>	Motorola Digital Communications.
<b>menu entry</b>	A software-activated feature shown at the bottom of the display. Selection of a feature is controlled by the programming of the buttons on the side of the radio.
<b>MHz</b>	<i>See Megahertz.</i>
<b>Megahertz</b>	One million cycles per second. Used especially as a radio-frequency unit.
<b>microcontroller unit</b>	Also written as $\mu\text{C}$ . A microprocessor that contains RAM and ROM components, as well as communications and programming components and peripherals.
<b>MISO</b>	<i>See Master In Slave Out.</i>

Term	Definition
<b>mode</b>	A programmed combination of operating parameters; for example, a channel or talkgroup.
<b>mode slaving</b>	A radio programmed to automatically provide the proper operation for a given selected mode.
<b>monitoring</b>	Used in conventional operation where the programmed monitor button is pressed to listen to another user who is active on a channel. This prevents one user from interfering with another user's conversation.
<b>MOSI</b>	<i>See Master Out Slave In.</i>
<b>multiplexer</b>	An electronic device that combines several signals for transmission on some shared medium (e.g., a telephone wire).
<b>MUX</b>	<i>See multiplexer.</i>
<b>Network Access Code</b>	Network Access Code (NAC) operates on digital channels to reduce voice channel interference between adjacent systems and sites.
<b>NiCd</b>	Nickel-cadmium.
<b>NiMH</b>	Nickel-metal-hydride.
<b>non-tactical/revert</b>	The user will talk on a preprogrammed emergency channel. The emergency alarm is sent out on this same channel.
<b>OMPAC</b>	<i>See over-molded pad-array carrier.</i>
<b>open architecture</b>	A controller configuration that utilizes a microprocessor with extended ROM, RAM, and EEPROM.
<b>oscillator</b>	An electronic device that produces alternating electric current and commonly employs tuned circuits and amplifying components.
<b>OSW</b>	<i>See outbound signaling word.</i>
<b>OTAR</b>	<i>See over-the-air rekeying.</i>
<b>outbound signaling word</b>	Data transmitted on the control channel from the central controller to the subscriber unit.
<b>over-molded pad-array carrier</b>	A Motorola custom IC package, distinguished by the presence of solder balls on the bottom pads.
<b>over-the-air rekeying</b>	Allows the dispatcher to remotely reprogram the encryption keys in the radio.
<b>PA</b>	Power amplifier.
<b>page</b>	A one-way alert with audio and/or display messages.
<b>paging</b>	One-way communication that alerts the receiver to retrieve a message.
<b>PC Board</b>	Printed Circuit Board. Also referred to as a PCB.



Term	Definition
<b>personality</b>	A set of unique features specific to a radio.
<b>phase-locked loop</b>	A circuit in which an oscillator is kept in phase with a reference, usually after passing through a frequency divider.
<b>PL</b>	<i>See private-line tone squelch.</i>
<b>PLL</b>	<i>See phase-locked loop.</i>
<b>preprogrammed</b>	A software feature that has been activated by a qualified radio technician.
<b>Private (Conversatiion) Call</b>	A feature that lets you have a private conversation with another radio user in the group.
<b>private-line tone squelch</b>	A continuous sub-audible tone that is transmitted along with the carrier. <i>See also DPL.</i>
<b>programmable</b>	A radio control that can have a radio feature assigned to it.
<b>Programmable Read-Only Memory</b>	A memory chip on which data can be written only once. Once data has been written onto a PROM, it remains there forever.
<b>PROM</b>	<i>See Programmable Read-Only Memory.</i>
<b>PTT</b>	<i>See Push-to-Talk.</i>
<b>Push-to-Talk</b>	The switch or button usually located on the left side of the radio which, when pressed, causes the radio to transmit. When the PTT is released, the unit returns to receive operation.
<b>radio frequency</b>	The portion of the electromagnetic spectrum between audio sound and infrared light (approximately 10 kHz to 10 GHz).
<b>radio frequency power amplifier</b>	Amplifier having one or more active devices to amplify radio signals.
<b>Radio Interface Box</b>	A service aid used to enable communications between a radio and the programming software.
<b>Radio Service Software</b>	DOS-based software containing the feature set of an ASTRO radio. <i>See also CPS.</i>
<b>random access memory</b>	A type of computer memory that can be accessed randomly; that is, any byte of memory can be accessed without touching the preceding bytes.
<b>RAM</b>	<i>See random access memory.</i>
<b>read-only memory</b>	A type of computer memory on which data has been prerecorded. Once data has been written onto a ROM chip, it cannot be removed and can only be read.
<b>real-time clock</b>	A module that keeps track of elapsed time even when a computer is turned off.

Term	Definition
<b>receiver</b>	Electronic device that amplifies RF signals. A receiver separates the audio signal from the RF carrier, amplifies it, and converts it back to the original sound waves.
<b>registers</b>	Short-term data-storage circuits within the microcontroller unit or programmable logic IC.
<b>repeater</b>	Remote transmit/receive facility that re-transmits received signals in order to improve communications range and coverage (conventional operation).
<b>repeater/talkaround</b>	A conventional radio feature that permits communication through a receive/transmit facility, which re-transmits received signals in order to improve communication range and coverage.
<b>RESET</b>	Reset line: an input to the microcontroller that restarts execution.
<b>RF</b>	<i>See radio frequency.</i>
<b>RF PA</b>	<i>See radio frequency power amplifier.</i>
<b>RIB</b>	<i>See Radio Interface Box.</i>
<b>ROM</b>	<i>See read-only memory.</i>
<b>RPCIC</b>	Regulator/power control IC.
<b>RPT/TA</b>	<i>See repeater/talkaround.</i>
<b>RSS</b>	<i>See Radio Service Software.</i>
<b>RSSI</b>	Received Signal Strength Indicator.
<b>RTC</b>	<i>See real-time clock.</i>
<b>RX</b>	Receive.
<b>RX DATA</b>	Recovered digital data line.
<b>SAP</b>	<i>See Serial Audio CODEC Port.</i>
<b>SCI IN</b>	Serial Communications Interface Input line.
<b>selective call</b>	A feature that allows you to call a selected individual, intended to provide privacy and to eliminate the annoyance of having to listen to conversations of no interest to you.
<b>selective switch</b>	Any digital P25 traffic having the correct Network Access Code and the correct talkgroup.
<b>Serial Audio CODEC Port</b>	SSI to and from the GCAP II IC CODEC used to transfer transmit and receive audio data.

Term	Definition
<b>Serial Communication Interface Input Line</b>	A full-duplex (receiver/transmitter) asynchronous serial interface.
<b>SCI IN</b>	<i>See Serial Communication Interface Input Line.</i>
<b>Serial Peripheral Interface</b>	How the microcontroller communicates to modules and ICs through the CLOCK and DATA lines.
<b>signal</b>	An electrically transmitted electromagnetic wave.
<b>Signal Qualifier mode</b>	An operating mode in which the radio is muted, but still continues to analyze receive data to determine RX signal type.
<b>softpot</b>	<i>See software potentiometer.</i>
<b>software</b>	Computer programs, procedures, rules, documentation, and data pertaining to the operation of a system.
<b>software potentiometer</b>	A computer-adjustable electronic attenuator.
<b>spectrum</b>	Frequency range within which radiation has specific characteristics.
<b>SPI</b>	<i>See Serial Peripheral Interface.</i>
<b>squelch</b>	Muting of audio circuits when received signal levels fall below a pre-determined value. With carrier squelch, all channel activity that exceeds the radio's preset squelch level can be heard.
<b>SRAM</b>	<i>See static RAM.</i>
<b>SRIB</b>	Smart Radio Interface Box. <i>See RIB.</i>
<b>SSI</b>	<i>See Synchronous Serial Interface.</i>
<b>Standby mode</b>	An operating mode in which the radio is muted but still continues to monitor data.
<b>static RAM</b>	A type of memory used for volatile, program/data memory that does not need to be refreshed.
<b>status calls</b>	Pre-defined text messages that allow the user to send a conditional message without talking.
<b>Synchronous Serial Interface</b>	DSP interface to peripherals that consists of a clock signal line, a frame synchronization signal line, and a data line.
<b>system central controllers</b>	Main control unit of the trunked dispatch system; handles ISW and OSW messages to and from subscriber units ( <i>See ISW and OSW</i> ).
<b>system select</b>	The act of selecting the desired operating system with the system-select switch (also, the name given to this switch).

Term	Definition
<b>tactical/non-revert</b>	The user will talk on the channel that was selected before the radio entered the emergency state.
<b>TalkAround</b>	Bypassing a repeater and talking directly to another unit for local unit-to-unit communications.
<b>talkgroup</b>	An organization or group of radio users who communicate with each other using the same communications path.
<b>talkgroup scan list</b>	A scan list that can include both talkgroups (trunked) and channels (conventional).
<b>thin small-outline package</b>	A type of dynamic random-access memory (DRAM) package that is commonly used in memory applications.
<b>time-out timer</b>	A timer that limits the length of a transmission.
<b>tone</b>	A continuous, sub-audible tone transmitted with the carrier.
<b>TOT</b>	<i>See time-out timer.</i>
<b>transceiver</b>	Transmitter-receiver. A device that both transmits and receives analog or digital signals. Also abbreviated as XCVR.
<b>transmitter</b>	Electronic equipment that generates and amplifies an RF carrier signal, modulates the signal, and then radiates it into space.
<b>trunking</b>	The automatic sharing of communications paths between a large number of users. Allows users to share a smaller number of frequencies because a repeater or communications path is assigned to a talkgroup for the duration of a conversation. <i>See also conventional.</i>
<b>trunking priority monitor scan list</b>	A scan list that includes talkgroups that are all from the same trunking system.
<b>TSOP</b>	<i>See thin small-outline package.</i>
<b>TX</b>	Transmit.
<b>UART</b>	<i>See also Universal Asynchronous Receiver Transmitter.</i>
<b>UHF</b>	Ultra-High Frequency.
<b>USK</b>	Unique shadow key.
<b>Universal Asynchronous Receiver Transmitter</b>	A microchip with programming that controls a computer's interface to its attached serial devices.
<b>Universal Connector</b>	Interface point for all accessories to the radio.
<b>Universal Serial Bus</b>	An external bus standard that supports data transfer rates of 12 Mbps.
<b>USB</b>	<i>See Universal Connector.</i>

Term	Definition
<b>VCO</b>	<i>See voltage-controlled oscillator.</i>
<b>vector sum excited linear predictive coding</b>	A voice-encoding technique used in ASTRO digital voice.
<b>VHF</b>	Very-High Frequency.
<b>VOCON</b>	<i>See vocoder/controller.</i>
<b>vocoder</b>	An electronic device for synthesizing speech by implementing a compression algorithm particular to voice. <i>See also voice encoder.</i>
<b>vocoder/controller</b>	A PC board that contains an ASTRO radio's microcontroller, DSP, memory, audio and power functions, and interface support circuitry.
<b>voice encoder</b>	The DSP-based system for digitally processing analog signals, and includes the capabilities of performing voice compression algorithms or voice encoding. <i>See also vocoder.</i>
<b>voltage-controlled oscillator</b>	An oscillator in which the frequency of oscillation can be varied by changing a control voltage.

## Notes





Motorola Solutions, Inc.  
1303 East Algonquin Road  
Schaumburg, Illinois 60196 U.S.A.

MOTOROLA, MOTO, MOTOROLA SOLUTIONS and the Stylized M logo are trademarks or registered trademarks of Motorola Trademark Holdings, LLC and are used under license. All other trademarks are the property of their respective owners. © 2009 – 2013 Motorola Solutions, Inc. All rights reserved. June 2013.



6875962M01-H